

Drive Electronics



WE CREATE MOTION

Speed Controller

			Page
SC 1801 P	for DC and Brushless Motors	1 A	544 – 545
SC 1801 F	for DC and Brushless Motors	1 A	546 – 547
SC 1801 S	for DC and Brushless Motors	1 A	548 – 549
SC 2402 P	for DC and Brushless Motors	2 A	550 – 551
SC 2804 S	for DC and Brushless Motors	4 A	552 – 553
SC 5004 P	for DC and Brushless Motors	4 A	554 – 555
SC 5008 S	for DC and Brushless Motors	8 A	556 – 557

Motion Controller

			Page
MCDC 3002 P	for DC-Micromotors	2 A	564 – 565
MCDC 3002 S	for DC-Micromotors	2 A	566 – 567
MCDC 3003 P	for DC-Micromotors	3 A	568 – 569
MCDC 3006 S	for DC-Micromotors	6 A	570 – 571
MCBL 3002 P	for Brushless DC-Motors	2 A	572 – 573
MCBL 3002 F	for Brushless DC-Motors	2 A	574 – 575
MCBL 3002 S	for Brushless DC-Motors	2 A	576 – 577
MCBL 3003 P	for Brushless DC-Motors	3 A	578 – 579
MCBL 3006 S	for Brushless DC-Motors	6 A	580 – 581
MCBL 3002 P AES	for Brushless DC-Motors with AES	2 A	582 – 583
MCBL 3002 F AES	for Brushless DC-Motors with AES	2 A	584 – 585
MCBL 3002 S AES	for Brushless DC-Motors with AES	2 A	586 – 587
MCBL 3003 P AES	for Brushless DC-Motors with AES	3 A	588 – 589
MCBL 3006 S AES	for Brushless DC-Motors with AES	6 A	590 – 591
MCLM 3002 P	for Linear DC-Servomotors	2 A	592 – 593
MCLM 3002 F	for Linear DC-Servomotors	2 A	594 – 595
MCLM 3002 S	for Linear DC-Servomotors	2 A	596 – 597
MCLM 3003 P	for Linear DC-Servomotors	3 A	598 – 599
MCLM 3006 S	for Linear DC-Servomotors	6 A	600 – 601
MC 5004 P	for DC, Brushless and Linear Motors	4 A	608 – 609
MC 5004 P STO	for Brushless and Linear Motors	4 A	610 – 611
MC 5005 S	for DC, Brushless and Linear Motors	5 A	612 – 613
MC 5010 S	for DC, Brushless and Linear Motors	10 A	614 – 615
MCST 3601	for Stepper Motors	1 A	620 – 621

FAULHABER Drive Electronics

Speed Controller

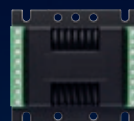

Series	SC 1801	SC 2402	SC 2804	SC 5004
For motor types	DC / BL*	DC / BL*	DC / BL*	DC / BL*
Supply voltage [V]	4 ... 18	5 ... 24	5 ... 28	6 ... 50
Continuous / peak current [A]	1 / 2	2 / 4	4 / 8	4 / 8
Speed range [min ⁻¹]	up to 100,000	up to 100,000	up to 100,000	up to 100,000
Temperature range [°C]	-25 ... +60	-25 ... +60	-25 ... +60	-25 ... +60
Channels	3	5	5	5

Speed Control Systems

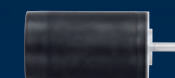

Series	1525 ... BRC	1935 ... BRC	3153 ... BRC	2232 ... BX4 SC
Motor type	Brushless, 2-pole	Brushless, 2-pole	Brushless, 2-pole	Brushless, 4-pole
Nominal voltage [V]	9 / 12 / 15	6 / 9 / 12	9 / 12 / 24	12 / 24
Continuous torque [mNm]	1.9	4.4	36.5	17.5
Speed range [min ⁻¹]	1,000 ... 25,000	1,000 ... 17,500	1,000 ... 10,500	up to 14,000
Temperature range [°C]	-25 ... +85	-25 ... +85	-25 ... +85	-40 ... +85

Motion Controllers

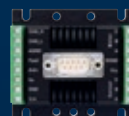

Series	MCxx 3002	MCxx 3003	MCxx 3006	MC 5004
For motor types	DC / BL / LM*	DC / BL / LM*	DC / BL / LM*	DC / BL / LM* (switchable)
Supply voltage [V]	5 ... 30	12 ... 30	12 ... 30	12 ... 50
Continuous / peak current [A]	2 / 3	3 / 10	6 / 10	4 / 12
Speed range [min ⁻¹]	5 ... 30,000	5 ... 30,000	5 ... 30,000	0 ... 60,000
Temperature range [°C]	-25 ... +85	-40 ... +85	-40 ... +85	-40 ... +85
Channels	5	5	5	13
Interface	RS232 / CANopen	RS232 / CANopen	RS232 / CANopen	RS232 / CANopen / EtherCAT / USB
Separate voltage supply	optional	optional	optional	yes

Motion Control Systems



Series	3564 ... B Cx	2232 ... BX4 CxD	2250 ... BX4 CxD	3242 ... BX4 Cx
Motor type	Brushless, 2-pole	Brushless, 4-pole	Brushless, 4-pole	Brushless, 4-pole
Nominal voltage [V]	24	12 / 24	12 / 24	24
Continuous torque [mNm]	71	16	25	67
Speed range [min ⁻¹]	1 ... 14,000	1 ... 11,300	1 ... 8,500	1 ... 6,500
Temperature range [°C]	-40 ... +85	-25 ... +85	-25 ... +85	-40 ... +100
Channels	3	3	3	3
Interface	RS232 / CANopen	RS232 / CANopen	RS232 / CANopen	RS232 / CANopen

Protection class

* DC = DC-Micromotors | BL = Brushless DC-Servomotors | LM = Linear DC-Servomotors

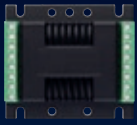
SC 5008

DC / BL*

6 ... 50

8 / 16

up to 100,000

-25 ... + 60

5

A wide range of compact and versatile electronic components are available for activating the FAULHABER drive systems, both as stand-alone versions and in an integrated form together with high-performance, brushless DC servomotors.

2250 ... BX4 SC

Brushless, 4-pole

12 / 24

25

up to 12,300

-40 ... + 85

3242 ... BX4 SC

Brushless, 4-pole

12 / 24

60

up to 11,500

-40 ... + 100

3268 ... BX4 SC

Brushless, 4-pole

24

99

up to 6,500

-40 ... + 100

2610 ... B SC

Brushless, 4-pole

6 / 12

3.12

up to 13,300

-25 ... + 80

2622 ... B SC

Brushless, 4-pole

6 / 12

100

4 ... 635

-25 ... + 80

MC 5004 STO

BL / LM* (switchable)

12 ... 50

4 / 12

0 ... 60,000

-40 ... + 85

13

 RS232 / CANopen /
EtherCAT / USB

yes

MC 5005

DC / BL / LM* (switchable)

12 ... 50

5 / 15

0 ... 60,000

-40 ... + 85

7

 RS232 / CANopen /
EtherCAT / USB

yes

MC 5010

DC / BL / LM* (switchable)

12 ... 50

10 / 30

0 ... 30,000

-40 ... + 85

7

 RS232 / CANopen /
EtherCAT / USB

yes

MCST 3601

Stepper

9 ... 36

1.1 / 1.6

-30 ... + 70

11

USB

yes

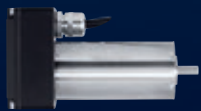
3268 ... BX4 Cx

Brushless, 4-pole

24

96

1 ... 6,400

-40 ... + 100

3

RS232 / CANopen

-

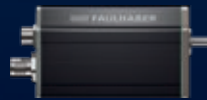
MCS 3242 ... BX4

Brushless, 4-pole

24

76

1 ... 6,200

-40 ... + 100

7

 RS232 / CANopen /
EtherCAT

IP 54 (opt.)

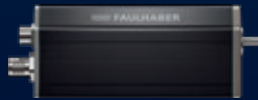
MCS 3268 ... BX4

Brushless, 4-pole

24

96

1 ... 6,000

-40 ... + 100

7

 RS232 / CANopen /
EtherCAT

IP 54 (opt.)

MCS 3274 ... BP4

Brushless, 4-pole

24

160

1 ... 11,600

-40 ... + 100

7

 RS232 / CANopen /
EtherCAT

IP 54 (opt.)

Speed Controller

Technical Information

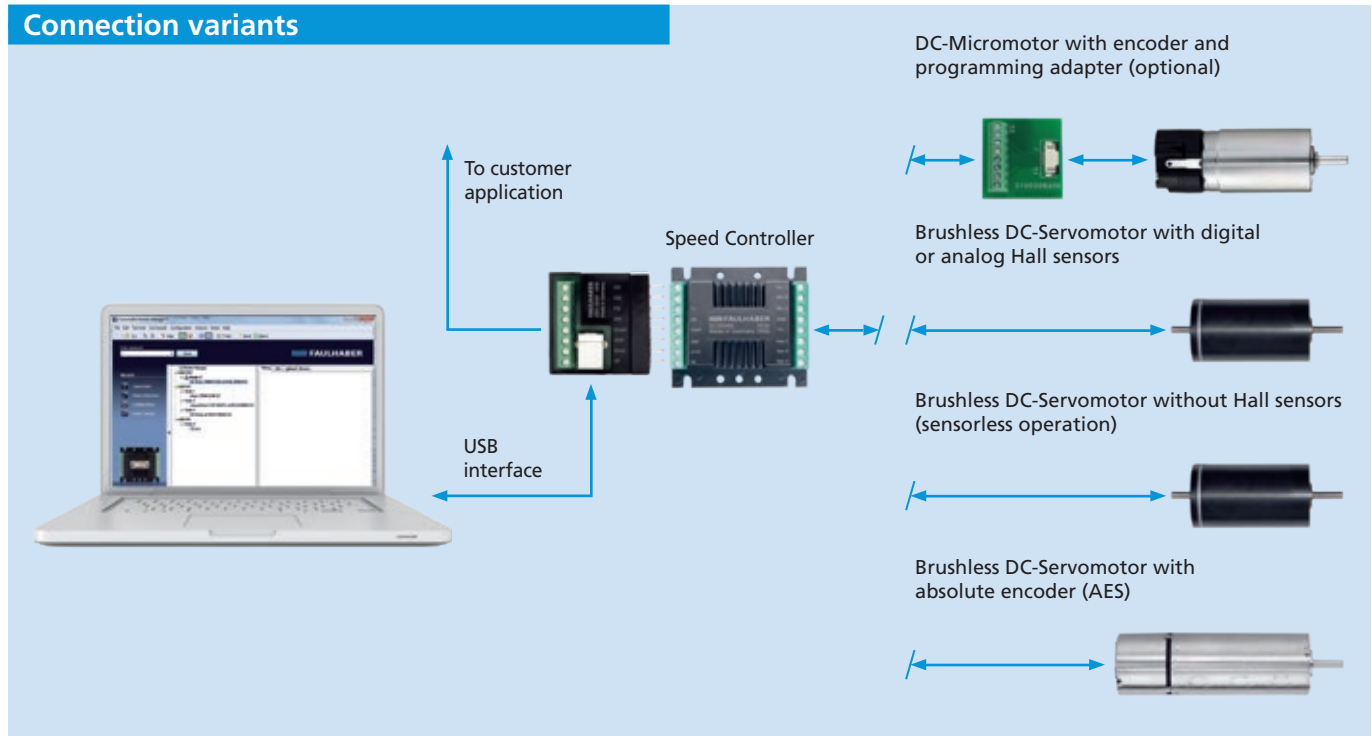

General Information

FAULHABER Speed Controllers are highly dynamic speed controllers for controlling:

- DC-Motors with and without incremental encoder
- BL motors with analog or digital Hall sensors
- BL motors with AES absolute encoder
- BL motors with digital Hall sensors and incremental encoders

Depending on the size and delivery state, different motor and sensor combinations can be operated on the Speed Controller.

Controller	DC sensorless	DC + encoder	BL sensorless	BL + D-Hall	BL + A-Hall	BL + AES
SC 1801	•	•	•	•	(2)	(2)
SC 2402/2804	•	•	•	• (1)	(2)	(2)
SC 5004/5008	-	•	-	• (1)	(2)	(2)

1) Optionally also available with additional incremental encoder input
 2) Optionally available

The different sizes as well as the flexible connection possibilities open a wide range of applications in areas such as laboratory technology and equipment manufacturing, automation technology, pick-and-place machines and machine tools, or pumps.

Product code

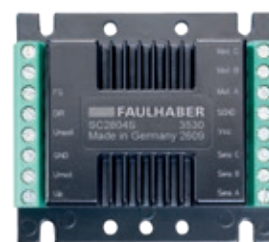

- SC Speed Controller
- 28 Max. supply voltage (28V)
- 04 Max. continuous output current (4A)
- S Housing with screw terminal
- 3530 Operating mode (brushless motor with digital Hall sensors)

SC_28_04_S_3530

General Information

FAULHABER Speed Controllers can be adapted to the application via the FAULHABER Motion Manager software. The type and scaling of the setpoint input, the operating mode and the control parameters can be adjusted. The USB programming adapter for Speed Controllers is used for configuration.

Speed Controllers are available with or without housing. The variants with housing are connected via screw terminals; the unboxed circuit-board variants can be directly plugged into a master board.

Interfaces – discrete I/O

- Analog input as set value input for setting the speed via PWM or analog voltage value
- Digital input as switching input for defining the direction of rotation of the motor
- Digital output, can be programmed either as frequency output or as error output

Note

Device manuals for installation and start-up, as well as the FAULHABER Motion Manager software, are available on request or on the Internet under www.faulhaber.com. Not all Speed Controllers are suitable for all operating modes. Detailed information on the individual operating modes can be found in the respective data sheets as well as in the technical manual.

Benefits

- Compact design
- Scalable in current and voltage
- Simple wiring
- Adapted versions for connecting different motors
- Integrated current limiting (motor protection)
- Controller setting can be configured in combination with Motion Manager via programming adapters
- Extensive range of supported DC-micromotors and brushless DC-servomotors

Speed Controller

Description & Operating Modes

Operating modes

The speed is controlled via a PI controller with variable parameters.

Depending on the version, the speed is determined via the connected sensor system or sensorless from the motor current.

Setpoint specification can be performed using an analog value or a PWM signal. The direction of rotation is changed via a separate switching input; the speed signal can be read out via the frequency output.

The motors can optionally be operated as a voltage controller or in fixed speed mode.

BL motors with digital or analog Hall sensors

In the "BL motors with Hall sensors" configuration, the motors are operated with speed control, whereby the signals from the Hall sensors are used for commutation and determination of the actual speed.

BL motors without Hall sensors (sensorless mode)

No Hall sensors are used in this configuration; instead, the back-EMF of the motor is used for commutation and speed control.

BL motors with absolute encoder

This mode can only be selected in combination with the appropriate hardware.

In this configuration, the encoder outputs an absolute position. This is used for commutation as well as for speed control. Owing to the high resolution of the encoder, it is possible to achieve low speeds in this mode.

BL motors with digital Hall sensors and brake/enable input

In this configuration, the motors are operated with speed control. The additional brake and enable inputs enable easier connection of the control to e.g. PLCs or safety circuits.

BL motors with digital Hall sensors and encoder

In this configuration, the Hall sensors output the information for commutation. The speed is controlled according to the signal from the incremental encoder.

For this reason, it is also possible to achieve extremely low speeds with a high-resolution encoder.

DC-Motors with encoder

In the "DC motors with encoder" configuration, the motors are operated with speed control. An incremental encoder is required as a speed actual value encoder.

DC-Motors without encoder

In the "sensorless DC motors" configuration, the motors are operated with speed control whereby, depending on the load condition, either the back electromotive force (EMF) or IxR compensation is used for speed actual value acquisition.

Matching to the respective motor type is required for this operating mode.

A number of other parameters can also be changed using the **"FAULHABER Motion Manager" software**:

- Controller parameters
- Output current limiting
- Fixed speed
- Encoder resolution
- Speed setpoint specification via analog or PWM signal
- Maximum speed or maximum speed range

Protective functions

FAULHABER Speed Controllers determine the temperature of the motor winding from the motor load characteristic. Dynamically, a peak current which is typically 2 times larger than the continuous current is available as a result; with a continuously higher load, the current is limited to the set continuous current.

In the case of frequent reversing operation with large connected masses, it is recommended to use a Motion Controller.

Special functions

For special applications, special functions such as ramps, switchable fixed speeds or more complex processes can be implemented ex works depending on the additional inputs. This allows FAULHABER Speed Controllers to be optimally adapted to the requirements of the specific application.

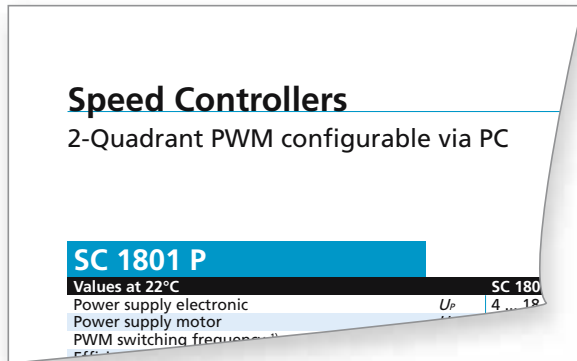

Notes on technical data sheet

The following data sheet values of the Speed Controllers are measured or calculated at an ambient temperature of 22°C.

Speed Controllers generally feature separate supply inputs for motor and electronics with the same ground connection; if necessary, these inputs can also be used as a common supply.

Power supply for electronics U_p [V DC]

Describes the range of the permissible supply voltage for the control electronics.

Power supply for motor U_{mot} [V DC]

Describes the range of the permissible supply voltage of the connected motor.

PWM switching frequency f_{PWM} [kHz]

Pulse width modulation describes the change of the electrical voltage between two values. The motors connected to the SCs have a low electrical time constant. To keep the losses associated with PWM low, a high switching frequency is necessary.

Electronics efficiency η [%]

Ratio between consumed and delivered power of the control electronics.

Max. continuous output current I_{cont} [A]

Describes the current that the controller can continuously deliver to the connected motor at 22°C ambient temperature without additional cooling.

Max. peak output current I_{max} [A]

Describes the current that the controller can reach in S2 operation (cold start without additional cooling) at nominal conditions under constant load for the time specified in the data sheet without exceeding the thermal limit. Unless otherwise defined, the value that applies for the peak current is equal to two times the continuous current.

Standby current for the electronics I_{el} [A]

Describes the additional current consumption of the control electronics.

Operating temperature range [°C]

Shows the minimum and maximum operating temperature under nominal conditions.

Housing material

Housing materials and, if necessary, surface treatment.

Mass [g]

The typical mass of the standard controller may vary due to the different components.

Note

Speed range

The speed that can be reached in combination with a motor depends on the available voltage, the respective motor type and the maximum processing speed of the selected speed controller.

The maximum speed range refers to motors with one pole pair. On motors with a larger number of pole pairs, the speed range decreases accordingly.

$$\text{Maximum speed} = \frac{\text{Maximum speed with number of pole pairs 1}}{\text{Number of pole pairs of the connected motor}}$$

Speed Controllers

2-Quadrant PWM configurable via PC

SC 1801 P

Values at 22°C		SC 1801 P	
Power supply electronic	U_P	4 ... 18	V DC
Power supply motor	U_{mot}	1,8 ... 18	V DC
PWM switching frequency ¹⁾	f_{PWM}	96	kHz
Efficiency electronic	η	95	%
Max. continuous output current	I_{cont}	1	A
Max. peak output current ²⁾	I_{max}	2	A
Standby current for electronic (at $U_P=12V$)	I_{el}	0,018	A
Operating temperature range		-25 ... +60	°C
Mass		4	g

¹⁾ for brushless DC-Motors without Hall sensors: $f_{PWM} = 24$ kHz

²⁾ S2 mode for max. 2s

Interfaces

Configuration of setpoint specifications, operating mode and controller parameters via USB programming adapter for Speed Controller.
 Note: The programming adapter cannot be directly connected in this version of the Speed Controller.

Basic features

Speed-controlled operation of:

- DC-Micromotors operated with or without incremental encoders
- Brushless DC-Servomotors operated with digital or analog Hall sensors

- Brushless DC-Servomotors operated without Hall sensors (sensorless Operation)
- Brushless DC-Servomotors operated with digital Hall sensors and incremental encoders
- Brushless DC-Servomotors operated with absolute encoders

Note: For version, see options and connection information.

Range of functions

Description	Intermittent operation with up to double the continuous current. Separate voltage supply for motor and electronics. Integrated speed control by means of PI controller. Sensorless operation by evaluating the back electromotive force (EMF). Setpoint input of the speed via PWM or analog voltage value. Switching input for defining the direction of rotation of the motor. Digital output, can be programmed either as frequency output or as error output
Additional functions	Integrated current limitation to protect against thermal overload. Can optionally be operated in voltage controller mode or fixed speed mode.

Speed Controllers

2-Quadrant PWM configurable via PC

SC 1801 F

Values at 22°C		SC 1801 F	
Power supply electronic	U_P	4 ... 18	V DC
Power supply motor	U_{mot}	1,8 ... 18	V DC
PWM switching frequency ¹⁾	f_{PWM}	96	kHz
Efficiency electronic	η	95	%
Max. continuous output current	I_{cont}	1	A
Max. peak output current ²⁾	I_{max}	2	A
Standby current for electronic (at $U_P=12V$)	I_{el}	0,018	A
Operating temperature range		-25 ... +60	°C
Housing material		Hotmelt	
Mass		10	g

¹⁾ for brushless DC-Motors without Hall sensors: $f_{PWM} = 24$ kHz

²⁾ S2 mode for max. 2s

Interfaces

Configuration of setpoint specifications, operating mode and controller parameters via USB programming adapter for Speed Controller.

Basic features

Speed-controlled operation of:

- DC-Micromotors operated with or without incremental encoders
- Brushless DC-Servomotors operated with digital or analog Hall sensors

- Brushless DC-Servomotors operated without Hall sensors (sensorless Operation)
- Brushless DC-Servomotors operated with digital Hall sensors and incremental encoders
- Brushless DC-Servomotors operated with absolute encoders

Note: For version, see options and connection information.

Range of functions

Description	Intermittent operation with up to double the continuous current. Separate voltage supply for motor and electronics. Integrated speed control by means of PI controller. Sensorless operation by evaluating the back electromotive force (EMF). Setpoint input of the speed via PWM or analog voltage value. Switching input for defining the direction of rotation of the motor. Digital output, can be programmed either as frequency output or as error output
Additional functions	Integrated current limitation to protect against thermal overload. Can optionally be operated in voltage controller mode or fixed speed mode.

Dimensional drawing

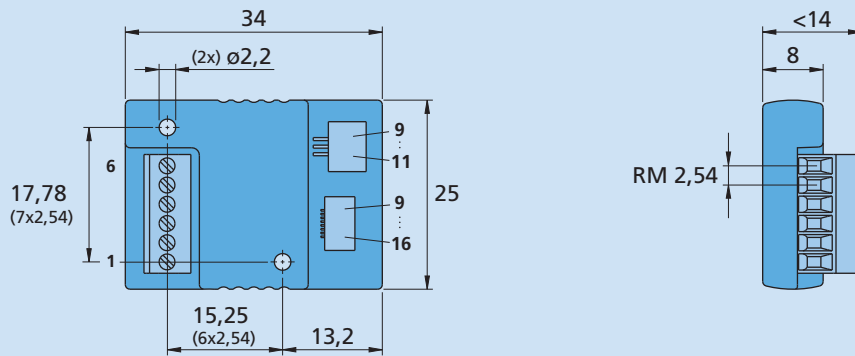

SC 1801 F

Connector Information
LIF-Connector
3-pole and 8-pole

Options and connection information

Example product designation: **SC 1801 F 3533**

Option	Type	Description	Connection	
			No.	Function
3533	BL	Sensorless (high speed)	9	Mot C
4763	BL	Absolute encoder 2 pole motors	10	Mot B
4289	BL	Analog Hall sensors 2 pole motors	11	Mot A
3980	BL	Absolute encoder 4 pole motors	12	SGND
4764	BL	Analog Hall sensors 4 pole motors	13	V _{CC}
3530	BL	Digital Hall sensors 2 pole motors	14	Sens C
			15	Sens B
			16	Sens A

Note: For details on the connection assignment, see device manual SC.

Product combination

Brushless DC-Motors	Cables / Accessories
0308 ... B 0515 ... B 0620 ... B	To view our large range of accessory parts, please refer to the „Accessories“ chapter.

Speed Controllers

2-Quadrant PWM configurable via PC

SC 1801 S

Values at 22°C		SC 1801 S	
Power supply electronic	U_P	4 ... 18	V DC
Power supply motor	U_{mot}	1,8 ... 18	V DC
PWM switching frequency ¹⁾	f_{PWM}	96	kHz
Efficiency electronic	η	95	%
Max. continuous output current	I_{cont}	1	A
Max. peak output current ²⁾	I_{max}	2	A
Standby current for electronic (at $U_P=12V$)	I_{el}	0,018	A
Operating temperature range		-25 ... +60	°C
Housing material		Hotmelt	
Mass		12	g

¹⁾ for brushless DC-Motors without Hall sensors: $f_{PWM} = 24$ kHz

²⁾ S2 mode for max. 2s

Interfaces

Configuration of setpoint specifications, operating mode and controller parameters via USB programming adapter for Speed Controller.

Basic features

Speed-controlled operation of:

- DC-Micromotors operated with or without incremental encoders
- Brushless DC-Servomotors operated with digital or analog Hall sensors

- Brushless DC-Servomotors operated without Hall sensors (sensorless Operation)
- Brushless DC-Servomotors operated with digital Hall sensors and incremental encoders
- Brushless DC-Servomotors operated with absolute encoders

Note: For version, see options and connection information.

Range of functions

Description	Intermittent operation with up to double the continuous current. Separate voltage supply for motor and electronics. Integrated speed control by means of PI controller. Sensorless operation by evaluating the back electromotive force (EMF). Setpoint input of the speed via PWM or analog voltage value. Switching input for defining the direction of rotation of the motor. Digital output, can be programmed either as frequency output or as error output
Additional functions	Integrated current limitation to protect against thermal overload. Can optionally be operated in voltage controller mode or fixed speed mode.

Speed Controllers

2-Quadrant PWM configurable via PC

SC 2402 P

Values at 22°C		SC 2402 P	
Power supply electronic	U_P	5 ... 24	V DC
Power supply motor	U_{mot}	0 ... 24	V DC
PWM switching frequency ¹⁾	f_{PWM}	96	kHz
Efficiency electronic	η	95	%
Max. continuous output current	I_{cont}	2	A
Max. peak output current ²⁾	I_{max}	4	A
Standby current for electronic (at $U_P=24V$)	I_{el}	0,03	A
Operating temperature range		-25 ... +60	°C
Mass		14	g

¹⁾ for brushless DC-Motors without Hall sensors: $f_{PWM} = 24$ kHz

²⁾ S2 mode for max. 6s

Interfaces

Configuration of setpoint specifications, operating mode and controller parameters via USB programming adapter for Speed Controller.
 Note: The programming adapter cannot be directly connected in this version of the Speed Controller.

Basic features

Speed-controlled operation of:

- DC-Micromotors operated with or without incremental encoders
- Brushless DC-Servomotors operated with digital or analog Hall sensors

- Brushless DC-Servomotors operated without Hall sensors (sensorless Operation)
- Brushless DC-Servomotors operated with digital Hall sensors and incremental encoders
- Brushless DC-Servomotors operated with absolute encoders

Note: For version, see options and connection information.

Range of functions

Description	Intermittent operation with up to double the continuous current. Separate voltage supply for motor and electronics. Integrated speed control by means of PI controller. Sensorless operation by evaluating the back electromotive force (EMF). Setpoint input of the speed via PWM or analog voltage value. Switching input for defining the direction of rotation of the motor. Digital output, can be programmed either as frequency output or as error output
Additional functions	Integrated current limitation to protect against thermal overload. Can optionally be operated in voltage controller mode or fixed speed mode.

Speed Controllers

2-Quadrant PWM configurable via PC

SC 2804 S

Values at 22°C		SC 2804 S	
Power supply electronic	U_P	5 ... 28	V DC
Power supply motor	U_{mot}	0 ... 28	V DC
PWM switching frequency ¹⁾	f_{PWM}	96	kHz
Efficiency electronic	η	95	%
Max. continuous output current	I_{cont}	4	A
Max. peak output current ²⁾	I_{max}	8	A
Standby current for electronic (at $U_P=24V$)	I_{el}	0,03	A
Operating temperature range		-25 ... +60	°C
Housing material		zinc, black coated	
Mass		160	g

¹⁾ for brushless DC-Motors without Hall sensors: $f_{PWM} = 24$ kHz

²⁾ S2 mode for max. 6s

Interfaces

Configuration of setpoint specifications, operating mode and controller parameters via USB programming adapter for Speed Controller.

Basic features

Speed-controlled operation of:

- DC-Micromotors operated with or without incremental encoders
- Brushless DC-Servomotors operated with digital or analog Hall sensors

- Brushless DC-Servomotors operated without Hall sensors (sensorless Operation)
- Brushless DC-Servomotors operated with digital Hall sensors and incremental encoders
- Brushless DC-Servomotors operated with absolute encoders

Note: For version, see options and connection information.

Range of functions

Description	Intermittent operation with up to double the continuous current. Separate voltage supply for motor and electronics. Integrated speed control by means of PI controller. Sensorless operation by evaluating the back electromotive force (EMF). Setpoint input of the speed via PWM or analog voltage value. Switching input for defining the direction of rotation of the motor. Digital output, can be programmed either as frequency output or as error output
Additional functions	Integrated current limitation to protect against thermal overload. Can optionally be operated in voltage controller mode or fixed speed mode.

Speed Controllers

4-Quadrant PWM configurable via PC

SC 5004 P

Values at 22°C		SC 5004 P	
Power supply electronic	U_P	6 ... 50	V DC
Power supply motor	U_{mot}	0 ... 50	V DC
PWM switching frequency ¹⁾	f_{PWM}	96	kHz
Efficiency electronic	η	95	%
Max. continuous output current	I_{cont}	4	A
Max. peak output current ²⁾	I_{max}	8	A
Standby current for electronic (at $U_P=24V$)	I_{el}	0,1	A
Operating temperature range		-25 ... +60	°C
Mass		14	g

¹⁾ for brushless DC-Motors without Hall sensors: $f_{PWM} = 24$ kHz

²⁾ S2 mode for max. 6s

Interfaces

Configuration of setpoint specifications, operating mode and controller parameters via USB programming adapter for Speed Controller.
 Note: The programming adapter cannot be directly connected in this version of the Speed Controller.

Basic features

Speed-controlled operation of:

- DC-Micromotors operated with incremental encoders
- Brushless DC-Servomotors operated with digital or analog Hall sensors

- Brushless DC-Servomotors operated with digital Hall sensors and incremental encoders
- Brushless DC-Servomotors operated with absolute encoders

Note: For version, see options and connection information.

Range of functions

Description	Intermittent operation with up to double the continuous current. Separate voltage supply for motor and electronics. Integrated speed control by means of PI controller. Setpoint input of the speed via PWM or analog voltage value. Switching input for defining the direction of rotation of the motor. Digital output, can be programmed either as frequency output or as error output
Additional functions	Integrated current limitation to protect against thermal overload. Can optionally be operated in voltage controller mode or fixed speed mode.

Speed Controllers

4-Quadrant PWM configurable via PC

SC 5008 S

Values at 22°C		SC 5008 S	
Power supply electronic	U_P	6 ... 50	V DC
Power supply motor	U_{mot}	0 ... 50	V DC
PWM switching frequency ¹⁾	f_{PWM}	96	kHz
Efficiency electronic	η	95	%
Max. continuous output current	I_{cont}	8	A
Max. peak output current ²⁾	I_{max}	16	A
Standby current for electronic (at $U_P=24V$)	I_{el}	0,1	A
Operating temperature range		-25 ... +60	°C
Housing material		zinc, black coated	
Mass		160	g

¹⁾ for brushless DC-Motors without Hall sensors: $f_{PWM} = 24$ kHz

²⁾ S2 mode for max. 6s

Interfaces

Configuration of setpoint specifications, operating mode and controller parameters via USB programming adapter for Speed Controller.

Basic features

Speed-controlled operation of:

- DC-Micromotors operated with incremental encoders
- Brushless DC-Servomotors operated with digital or analog Hall sensors

- Brushless DC-Servomotors operated with digital Hall sensors and incremental encoders
- Brushless DC-Servomotors operated with absolute encoders

Note: For version, see options and connection information.

Range of functions

Description	Intermittent operation with up to double the continuous current. Separate voltage supply for motor and electronics. Integrated speed control by means of PI controller. Setpoint input of the speed via PWM or analog voltage value. Switching input for defining the direction of rotation of the motor. Digital output, can be programmed either as frequency output or as error output
Additional functions	Integrated current limitation to protect against thermal overload. Can optionally be operated in voltage controller mode or fixed speed mode.

Motion Controllers

Feature Comparison

General Information

FAULHABER Motion Controllers are highly dynamic positioning systems, available in housed and unhoused variants and control DC, LM or BL motors. The Motion Controllers are configured here via the FAULHABER Motion Manager.

The drives can be operated in the network via the CANopen or EtherCAT fieldbus interface (only MC V3.0). In smaller setups, networking can also be performed via the RS232 interface. The Motion Controllers operate in the network in principle as a slave; master functionality for actuating other axes is not provided.

After basic commissioning via Motion Manager, the controllers can alternatively also be operated without communication interface.

Generation V2.5

- Proven technology for BL, DC and LM motors
- Very simple configuration and start-up

- Numerous configuration options
- Successfully used in medical and laboratory technology, equipment manufacturing, automation, medical technology and aerospace
- Also available in very small sizes

Generation V3.0

A new generation of controllers for applications that go beyond the features and performance offered by the V2.5 controller series.

- More power, faster control, new operating modes
- One controller for all motor types and encoder systems
- Flexible use of the I/Os for setpoints and actual values
- Additional I/Os and interfaces
- Sequential programs can be programmed in BASIC for simple, local automation in all interface technologies
- Expanded diagnostic functions
- Simple start-up via Motion Manager beginning with version 6.0

	Generation V2.5		Generation V3.0	
	MCxx 3002	MCxx 3003/06	MC 5004	MC 5005/10
Voltage ranges	<ul style="list-style-type: none"> ■ Motor: max. 30V ■ Electronics: max. 30V, optionally separated 		<ul style="list-style-type: none"> ■ Motor: max. 50V ■ Electronics: max. 50V, separated standard 	
Continuous current	2A	3 / 6A	4A	5 / 10A
Peak current	3A	10A	12A	15 / 30A
Motor types	<ul style="list-style-type: none"> ■ MCDC: DC + Encoder ■ MCBL: BL + A-Hall ■ MCLM: LM + A-Hall ■ MCBL AES: BL + AES Encoder 		<ul style="list-style-type: none"> ■ DC motors with pos. / speed sensor ■ BL motors with pos. / speed sensor ■ LM motors with pos. / speed sensor 	
Speed and position sensors	see motor types		<ul style="list-style-type: none"> ■ DC motors: incremental¹⁾, AES Encoder¹⁾, SSI encoder¹⁾, analog value (potentiometer/tachometer) ■ BL/LM motors: D-Hall, D-Hall + Encoder¹⁾, A-Hall, AES encoder¹⁾, SSI encoder¹⁾, analog value (potentiometer/tachometer) 	
Inputs/outputs	MCDC: DigIn: max. 5 DigOut: max. 1 AnIn ±10V: 1	MCBL/MCLM: DigIn: max. 3 DigOut: max. 1 AnIn ±10V: 1	DigIn: 8 DigOut: 3 AnIn ±10V: 2	DigIn: 3 DigOut: 2 AnIn ±10V: 2
	Optional connection of a second reference encoder (Gearing mode). Not all I/Os available depending on wiring.		Optional connection of a second reference encoder (Gearing mode).	
Communication	RS232 or CANopen		USB, RS232 and/or CANopen, EtherCAT	
Controller	Position, speed, current limiting		Position, speed, current / torque	
Operating modes	<ul style="list-style-type: none"> ■ Depending on the interface variant, position, speed and current control with setpoint input via the interface or analog (RS) 		<ul style="list-style-type: none"> ■ Profile Position mode (PP) and Profile Velocity mode (PV), taking into account profile settings ■ Cyclic Synchronous Position, speed or torque (CSP, CSV or CST) ■ Analog input for position, speed, torque or voltage (APC, AVC, ATC, volt) 	
Profile operation	Linear trapezoidal profiles in all operating modes		Linear or sin ² speed in PP and PV modes	
Autonomous processes	Available in the versions with RS232 interface		Up to eight sequential programs in all versions, with optional password protection	

¹⁾ with and without Line driver

Motion Controllers

Technical Information

Connection variants

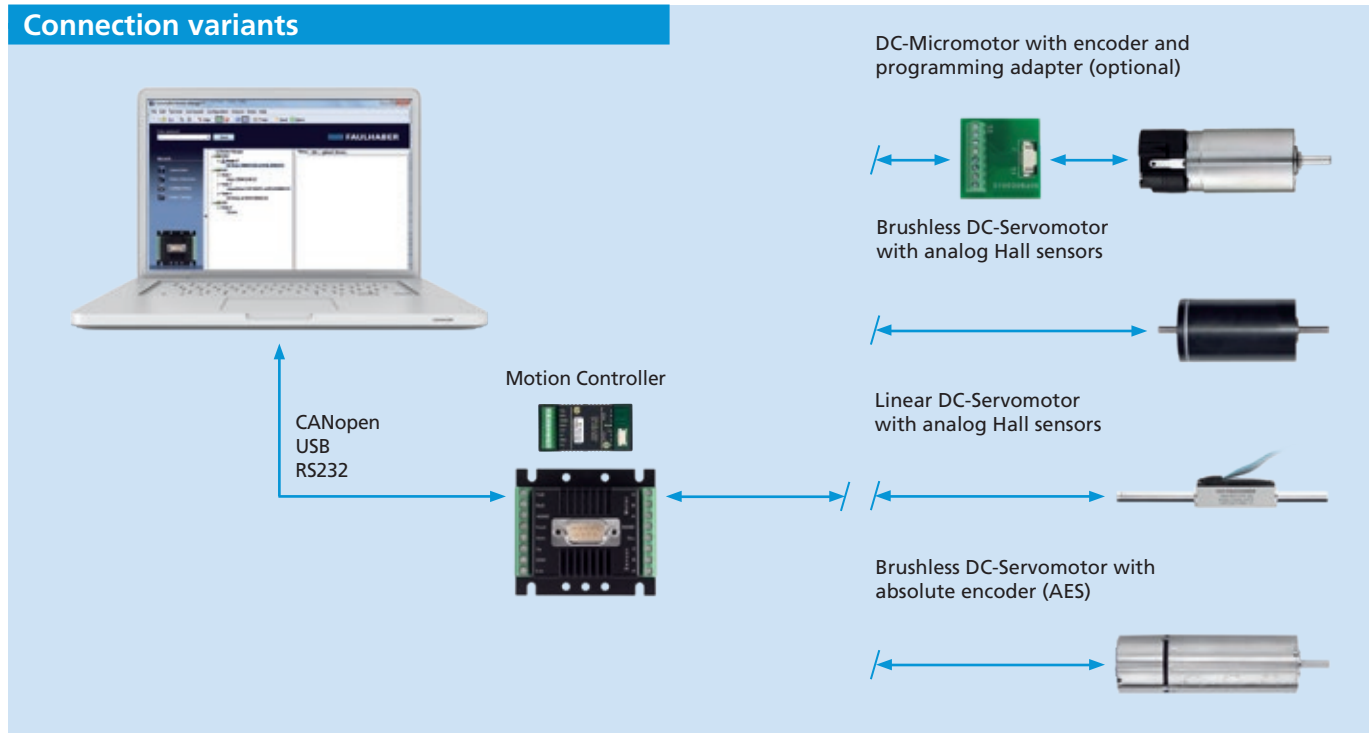

Features

FAULHABER Motion Controllers of generation V2.5 are highly dynamic positioning systems for controlling different motors and sensor systems:

- MCDC 300x: DC-Motors with incremental encoder
- MCBL 300x: BL-motors with analog Hall signals
- MCLM 300x: LM-motors with analog Hall signals
- MCBL 300x AES: BL-motors with absolute encoder

In addition to use as a servo drive with controlled position, the speed can also be controlled. Via the integrated current control, the torque is limited and the electronics or the connected motor protected against overload.

Motion Controllers of generation V2.5 are available in various sizes and performance classes as well as with RS232 or with CAN interface and, as a result, can also be integrated in networks. In addition to operation on a PC, the systems can also be operated on all common industrial controls.

The Motion Controllers are available with or without housing. The variants with housing are connected via screw terminals; the unboxed circuit-board variants can be directly plugged into a master board.

Benefits

- Compact design
- Can be controlled either via RS232 or CAN interface
- Minimal wiring requirements
- Configurable using the "FAULHABER Motion Manager" software and USB interface
- Extensive range of accessories
- Simple start-up

Product code

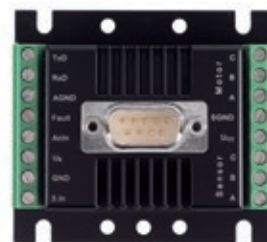

MC	Motion Controller
BL	For Brushless DC-Motors
30	Max. supply voltage (30 V)
06	Max. continuous output current (6 A)
S	Housing with screw terminal
CO	CAN interface

MC₁BL₁30₁06₁S₁CO

Motion Controllers

Configuration, networking, interfaces

Operating modes

Positioning operation

The drive moves to the preset target position and, in doing so, maintains the specified limits for speed and position. The dynamics of the control can be adapted to a wide range of loads. Limit switches can be evaluated directly. The position can be initialised via limit switches or a reference switch.

Speed control

The drive controls the preset target speed via a PI speed controller without lasting deviation.

Current control

Protects the drive by limiting the motor current to the set peak current. By means of integrated thermal models, the current is limited to the continuous current if necessary.

Motion profiles

Acceleration and brake ramp as well as the maximum speed can be preset in speed and positioning operation.

Autonomous operation

In version RS, freely programmable processes can be stored in the Motion Controller. Operation is then also possible without RS232 interface.

Protective features

- Protection against ESD
- Overload protection for electronics and motor
- Self-protection from overheating
- Overvoltage protection in generator mode

Operating modes (RS version)

- Position control
 - with setpoint input via the interface
 - with analog setpoint
 - gearing mode
 - stepper motor operation
- Speed control
 - with setpoint input via the interface
 - with analog setpoint
- Torque control
 - with setpoint input via the interface
 - with analog setpoint
- Operation as Servo Amplifier in voltage controller mode

Operating modes (CO version)

- Profile Position mode (PP)
- Profile Velocity mode (PV)
- Homing mode

Options

Separate supply of power to the motor and electronic actuator is optional (important for safety-critical applications).

Third input is not available with this option. Depending on the controller, additional programming adapters and connection aids are available. The modes and parameters can be specially pre-configured on request.

Interfaces – discrete I/O

Setpoint input

Depending on the operating mode, setpoints can be input via the command interface, via an analog voltage value, a PWM signal or a quadrature signal.

Error output (Open Collector)

Configured as error output (factory setting). Also usable as digital input, free switch output, for speed control or signaling an achieved position.

Additional digital inputs

For evaluating reference switches.

Interfaces – position encoder

Depending on the model, one of the listed interfaces for the position and speed sensor is supported.

Analog Hall signals

Three analog Hall signals, offset by 120°, in Brushless DC-Motors and Linear DC-Servomotors.

Incremental encoder

In DC-Micromotors and as additional sensors for Brushless DC-Motors.

Absolute encoder

Serial SSI port, matching Brushless DC-Servomotors with AES encoders.

Networking

FAULHABER Motion Controllers of generation V2.5 are available in all two networking versions.

RS – systems with RS232 interface

Ideal for equipment manufacturing and for all applications in which the controller is also to be used without a higher level controller. Using Net mode, it is also possible to operate multiple RS controllers on an RS232 interface.

CO – CANopen acc. to CiA 402

The ideal variant for the operation of a FAULHABER Motion Controller on a PLC – directly via the CANopen interface or via a gateway on, e.g., Profibus/ProfiNET or on EtherCAT.

The CO version provides the CiA 402 standard operating modes. All the parameters are directly stored in the object directory. Configuration can therefore be performed with the help of the FAULHABER Motion Manager or by applying available standardized configurations tools common to the automation market.

The CO version is particularly suitable for users who already use various CANopen devices or operate the Motion Controllers on a PLC. With dynamic PDO mapping it is possible to achieve highly efficient networking on the CAN.

Interfaces – Bus Connection

Version with RS232

For coupling to a PC with a transfer rate of up to 115 kbaud. Multiple drives can be connected to a single controller using the RS232 interface. As regards the control computer, no special arrangements are necessary. The interface also offers the possibility of retrieving online operational data and values.

A comprehensive ASCII command set is available for programming and operation. This can be preset from the PC using the “FAULHABER Motion Manager” software or from another control computer.

Additionally, there is the possibility of creating complex processes from these commands and storing them on the drive. Once programmed as a speed or positioning controller via the analog input, as step motor or electronic gear unit, the drive can operate independently of the RS232 interface.

Version with CANopen CO

A controller variant with CANopen interface is available to allow optimal integration in a wide variety of different applications. CANopen is ideal for networking microdrives because the interface can also be integrated in small electronics modules. Its size and the efficient communication procedures mean that it is ideally suited for use in industrial automation.

Motion Controllers

Configuration, networking, interfaces

Features CO

	CO
NMT with node guarding	•
Baud rate	1 Mbit max., LSS
EMCY object	•
SYNCH object	•
Server SDO	1 x
PDOs	4 x Rx 4 x Tx each with dynamic mapping
PDO ID	adjustable
Configuration	Motion Manager from V5
Trace	Any PDO
Standard operating modes	•
- Profile Position Mode - Profile Velocity Mode - Homing	

The model supports the CANopen communication profile acc. to CiA 301 V4.02. Transfer rate and node number are set via the network in accordance with the LSS protocol as defined in CiA 305 V1.11.

For this purpose, we recommend using the latest version of the FAULHABER Motion Manager.

Note

Device manuals for installation and commissioning, communication and function manuals as well as the "FAULHABER Motion Manager" software are available on request or on the Internet under www.faulhaber.com.

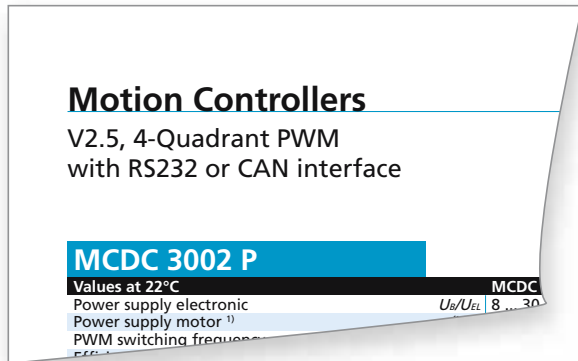

Notes on technical data sheet

The following data sheet values of the Motion Controllers of generation V2.5 are measured or calculated at an ambient temperature of 22°C. In their standard version, the Motion Controllers do not have separate supply inputs for motor and electronics, but can optionally be equipped with these inputs (via 3rd input).

Power supply for electronics U_B / U_{EL} [V DC]

Describes the range of the permissible supply voltage for the control electronics.

Power supply for motor -- U_B [V DC]

Describes the range of the permissible supply voltage of the connected motor.

PWM switching frequency f_{PWM} [kHz]

Pulse width modulation describes the change of the electrical voltage between two values. The motors connected to the MCs have a low electrical time constant. To keep the losses associated with PWM low, a high switching frequency is necessary.

Electronics efficiency η [%]

Ratio between consumed and delivered power of the control electronics.

Max. continuous output current I_{cont} [A]

Describes the current that the controller can continuously deliver to the connected motor at 22°C ambient temperature without additional cooling.

Max. peak output current I_{max} [A]

Describes the current that the controller can reach in S2 operation (cold start without additional cooling) at nominal conditions under constant load for the time specified in the data sheet without exceeding the thermal limit. Depending on the size and version, the value is up to three times higher for the ratio of peak current to continuous current.

Standby current for the electronics I_{el} [A]

Describes the additional current consumption of the control electronics.

Operating temperature range [°C]

Shows the minimum and maximum operating temperature under nominal conditions.

Housing material

Housing materials and, if necessary, surface treatment.

Mass [g]

The typical mass of the standard controller may vary within the individual interface variants due to the different components.

Note

Speed range

The speed that can be reached in combination with a motor depends on the available voltage, the respective motor type and the maximum processing speed of the selected motion controller.

The maximum speed range refers to motors with one pole pair. On motors with a larger number of pole pairs, the speed range decreases accordingly.

$$\text{Maximum speed} = \frac{\text{Maximum speed with number of pole pairs 1}}{\text{Number of pole pairs of the connected motor}}$$

Motion Controllers

V2.5, 4-Quadrant PWM
with RS232 or CAN interface

MCDC 3002 P

Values at 22°C		MCDC 3002 P	
Power supply electronic	U_B/U_{EL}	8 ... 30	V DC
Power supply motor ¹⁾	$-/U_B$	0 ... 30	V DC
PWM switching frequency	f_{PWM}	78,12	kHz
Efficiency electronic	η	95	%
Max. continuous output current	I_{cont}	2	A
Max. peak output current ²⁾	I_{max}	3	A
Standby current for electronic (at $U_B=24V$)	I_{el}	0,04	A
Operating temperature range		-25 ... +85	°C
Mass		7	g

¹⁾ Only available for option 3085 (separate power supply)

²⁾ S2 mode for max. 5s

Interfaces	MCDC 3002 P RS	MCDC 3002 P CO
Interface	RS232	CAN (CiA)
Protocol	FAULHABER - ASCII	CANopen

Basic features

- Operation of brushed DC-Micromotors
- Supported sensor systems: incremental encoders
- Positioning resolution per revolution depending on the used encoder type
- Max. 5 digital inputs, max. 1 digital output, 1 analog input. Not all I/Os available depending on wiring
- Setpoint specification via fieldbus, quadrature signal, pulse and direction or analog inputs
- Optional stand-alone operation via application programs with the RS232 interface version

Range of functions

Operating modes (RS Versions)	Position, speed and torque control with setpoint specification via interface or analog. Position control with Gearing Mode or stepper motor operation. Operation as Servo Amplifier in voltage controller mode
Operating modes (CO Version)	Profile Position Mode (PP), Profile Velocity Mode (PV), Homing Mode. Cyclic Synchronous Position Mode (CSP) acc. to IEC 61800-7-201 or IEC 61800-7-301.
Speed range	5 min ⁻¹ ... 30 000 min ⁻¹
Application programs	Available in versions with RS232 interface
Additional functions	Overload protection for electronics and motor, self-protection from overheating, over-voltage protection in generator mode.
Indicator	Trace as logger
Motor types	Brushed DC-Micromotors with incremental encoders

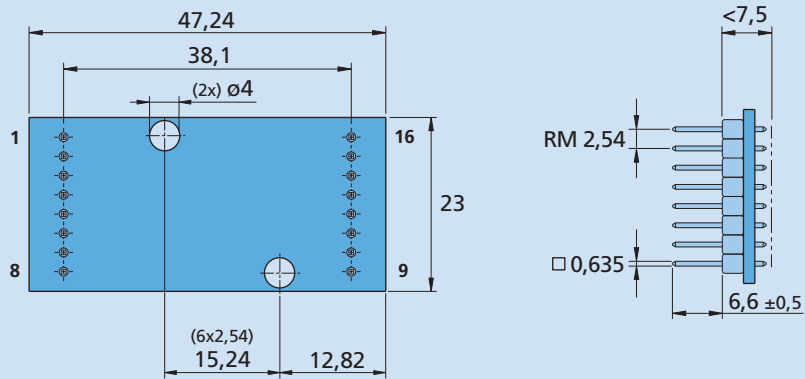
Dimensional drawing

MCDC 3002 P
Options and connection information

 Example product designation: **MCDC 3002 P RS 3085**

Option	Type	Description	Connection	
			No.	Function
3085	Supply	Separate power supply for motor and electronics	1	TxD / CAN_H
			2	RxD / CAN_L
			3	AGND
			4	Fault
			5	AnIn
			6	U _B
			7	GND
			8	3. In
			9	4. In
			10	Ch A
			11	Ch B
			12	U _{CC}
			13	SGND
			14	Mot +
			15	Mot -
			16	5. In

Note: For details on the connection assignment, see device manual MC.

Product combination

DC-Motors	Cables / Accessories
0615 ... S 0816 ... SR 1016 ... SR 1024 ... SR 1224 ... SR 1319 ... SR 1331 ... SR 1336 ... CXR 1516 ... SR 1524 ... SR 1717 ... SR 1724 ... SR 1727 ... CXR 1741 ... CXR 2224 ... SR 2230 ... S 2232 ... SR 2233 ... S 2237 ... CXR	2342 ... CR 2642 ... CXR To view our large range of accessory parts, please refer to the „Accessories“ chapter.

Motion Controllers

V2.5, 4-Quadrant PWM
with RS232 or CAN interface

MCDC 3002 S

Values at 22°C		MCDC 3002 S	
Power supply electronic	U_B/U_{EL}	8 ... 30	V DC
Power supply motor ¹⁾	$-U_B$	0 ... 30	V DC
PWM switching frequency	f_{PWM}	78,12	kHz
Efficiency electronic	η	95	%
Max. continuous output current	I_{cont}	2	A
Max. peak output current ²⁾	I_{max}	3	A
Standby current for electronic (at $U_B=24V$)	I_{el}	0,04	A
Operating temperature range		-25 ... +85	°C
Housing material		Hotmelt	
Mass		16	g

¹⁾ Only available for option 3085 (separate power supply)

²⁾ S2 mode for max. 5s

Interfaces	MCDC 3002 S RS	MCDC 3002 S CO
Interface	RS232	CAN (CiA)
Protocol	FAULHABER - ASCII	CANopen

Basic features

- Operation of brushed DC-Micromotors
- Supported sensor systems: incremental encoders
- Positioning resolution per revolution depending on the used encoder type
- Max. 5 digital inputs, max. 1 digital output, 1 analog input. Not all I/Os available depending on wiring
- Setpoint specification via fieldbus, quadrature signal, pulse and direction or analog inputs
- Optional stand-alone operation via application programs with the RS232 interface version

Range of functions

Operating modes (RS Versions)	Position, speed and torque control with setpoint specification via interface or analog. Position control with Gearing Mode or stepper motor operation. Operation as Servo Amplifier in voltage controller mode
Operating modes (CO Version)	Profile Position Mode (PP), Profile Velocity Mode (PV), Homing Mode. Cyclic Synchronous Position Mode (CSP) acc. to IEC 61800-7-201 or IEC 61800-7-301.
Speed range	5 min ⁻¹ ... 30 000 min ⁻¹
Application programs	Available in versions with RS232 interface
Additional functions	Overload protection for electronics and motor, self-protection from overheating, over-voltage protection in generator mode.
Indicator	Trace as logger
Motor types	Brushed DC-Micromotors with incremental encoders

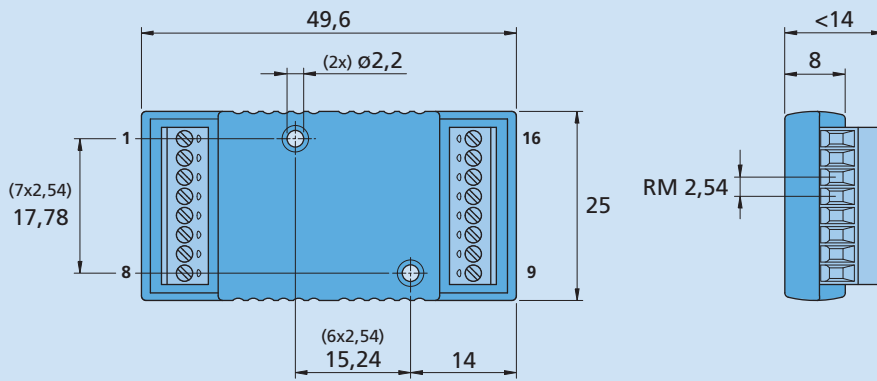
Dimensional drawing

MCDC 3002 S
Options and connection information

 Example product designation: **MCDC 3002 S RS 3085**

Option	Type	Description	Connection	
			No. Function	No. Function
3085	Supply	Separate power supply for motor and electronics	1 TxD / CAN_H	9 4. In
			2 RxD / CAN_L	10 Ch A
			3 AGND	11 Ch B
			4 Fault	12 U _{cc}
			5 AnIn	13 SGND
			6 U _B	14 Mot +
			7 GND	15 Mot -
			8 3. In	16 5. In

Note: For details on the connection assignment, see device manual MC.

Product combination

DC-Motors	Cables / Accessories
0615 ... S 0816 ... SR 1016 ... SR 1024 ... SR 1224 ... SR 1319 ... SR 1331 ... SR 1336 ... CXR 1516 ... SR 1524 ... SR 1717 ... SR 1724 ... SR 1727 ... CXR 1741 ... CXR 2224 ... SR 2230 ... S 2232 ... SR 2233 ... S 2237 ... CXR	2342 ... CR 2642 ... CXR To view our large range of accessory parts, please refer to the „Accessories“ chapter.

Motion Controllers

V2.5, 4-Quadrant PWM
with RS232 or CAN interface

MCDC 3003 P

Values at 22°C	MCDC 3003 P		
Power supply electronic	U_B/U_{EL}	12 ... 30	V DC
Power supply motor ¹⁾	$-U_B$	0 ... 30	V DC
PWM switching frequency	f_{PWM}	78,12	kHz
Efficiency electronic	η	95	%
Max. continuous output current	I_{cont}	3	A
Max. peak output current ²⁾	I_{max}	10	A
Standby current for electronic (at $U_B=24V$)	I_{el}	0,06	A
Operating temperature range		-40 ... +85	°C
Mass		18	g

¹⁾ Only available for option 3085 (separate power supply)

²⁾ S2 mode for max. 2s

Interfaces	MCDC 3003 P RS	MCDC 3003 P CO
Interface	RS232	CAN (CiA)
Protocol	FAULHABER - ASCII	CANopen

Basic features

- Operation of brushed DC-Micromotors
- Supported sensor systems: incremental encoders
- Positioning resolution per revolution depending on the used encoder type
- Max. 5 digital inputs, max. 1 digital output, 1 analog input. Not all I/Os available depending on wiring
- Setpoint specification via fieldbus, quadrature signal, pulse and direction or analog inputs
- Optional stand-alone operation via application programs with the RS232 interface version

Range of functions

Operating modes (RS Versions)	Position, speed and torque control with setpoint specification via interface or analog. Position control with Gearing Mode or stepper motor operation. Operation as Servo Amplifier in voltage controller mode
Operating modes (CO Version)	Profile Position Mode (PP), Profile Velocity Mode (PV), Homing Mode.
Speed range	5 min ⁻¹ ... 30 000 min ⁻¹
Application programs	Available in versions with RS232 interface
Additional functions	Overload protection for electronics and motor, self-protection from overheating, over-voltage protection in generator mode.
Indicator	Trace as logger
Motor types	Brushed DC-Micromotors with incremental encoders

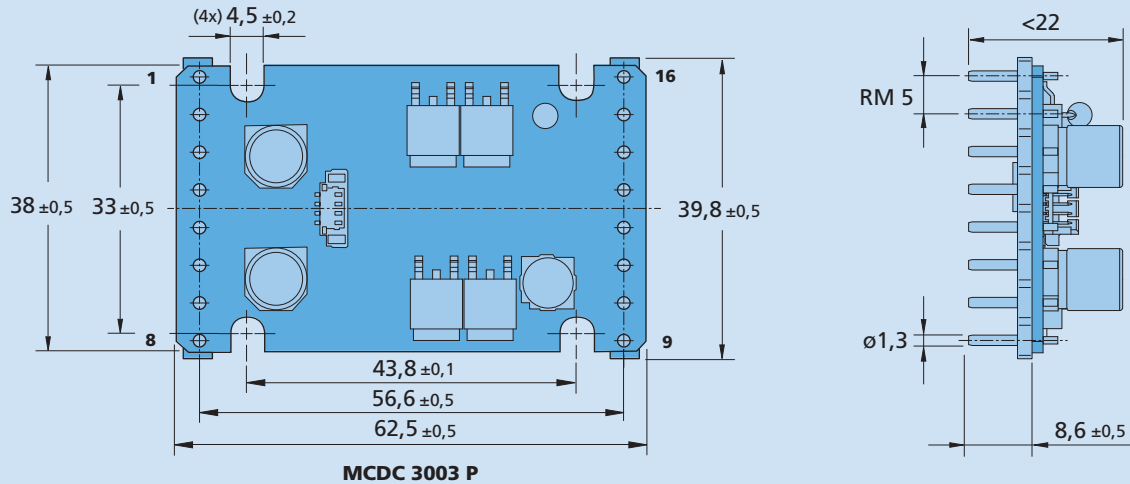
Dimensional drawing

Options and connection information

 Example product designation: **MCDC 3003 P RS 3085**

Option	Type	Description	Connection	
			No. Function	No. Function
3085	Supply	Separate power supply for motor and electronics	1 TxD / CAN_H	9 5. In
			2 RxD / CAN_L	10 4. In
			3 AGND	11 Ch A
			4 Fault	12 Ch B
			5 AnIn	13 U _{CC}
			6 U _B	14 SGND
			7 GND	15 Mot +
			8 3. In	16 Mot -

Max. recommended current for continuous operation:
3A (at 22 °C ambient temperature)

CAUTION: Thermal shutdown is NOT guaranteed!

Note: For details on the connection assignment, see device manual MC.

Product combination

DC-Motors	Cables / Accessories
1741 ... CXR 2224 ... SR 2230 ... S 2232 ... SR 2233 ... S 2237 ... CXR 2342 ... CR 2642 ... CR 2642 ... CXR 2657 ... CR 2657 ... CXR 2668 ... CR 3242 ... CR 3257 ... CR 3272 ... CR	To view our large range of accessory parts, please refer to the „Accessories“ chapter.

Motion Controllers

V2.5, 4-Quadrant PWM
with RS232 or CAN interface

MCDC 3006 S

Values at 22°C		MCDC 3006 S	
Power supply electronic	U_B/U_{EL}	12 ... 30	V DC
Power supply motor ¹⁾	$-U_B$	0 ... 30	V DC
PWM switching frequency	f_{PWM}	78,12	kHz
Efficiency electronic	η	95	%
Max. continuous output current	I_{cont}	6	A
Max. peak output current ²⁾	I_{max}	10	A
Standby current for electronic (at $U_B=24V$)	I_{el}	0,06	A
Operating temperature range		-40 ... +85	°C
Housing material		zinc, black coated	
Mass		160	g

¹⁾ Only available for option 3085 (separate power supply)

²⁾ S2 mode for max. 9s

Interfaces	MCDC 3006 S RS	MCDC 3006 S CO
Interface	RS232	CAN (CiA)
Protocol	FAULHABER - ASCII	CANopen

Basic features

- Operation of brushed DC-Micromotors
- Supported sensor systems: incremental encoders
- Positioning resolution per revolution depending on the used encoder type
- Max. 5 digital inputs, max. 1 digital output, 1 analog input. Not all I/Os available depending on wiring
- Setpoint specification via fieldbus, quadrature signal, pulse and direction or analog inputs
- Optional stand-alone operation via application programs with the RS232 interface version

Range of functions

Operating modes (RS Versions)	Position, speed and torque control with setpoint specification via interface or analog. Position control with Gearing Mode or stepper motor operation. Operation as Servo Amplifier in voltage controller mode
Operating modes (CO Version)	Profile Position Mode (PP), Profile Velocity Mode (PV), Homing Mode.
Speed range	5 min ⁻¹ ... 30 000 min ⁻¹
Application programs	Available in versions with RS232 interface
Additional functions	Overload protection for electronics and motor, self-protection from overheating, over-voltage protection in generator mode.
Indicator	Trace as logger
Motor types	Brushed DC-Micromotors with incremental encoders

Dimensional drawing

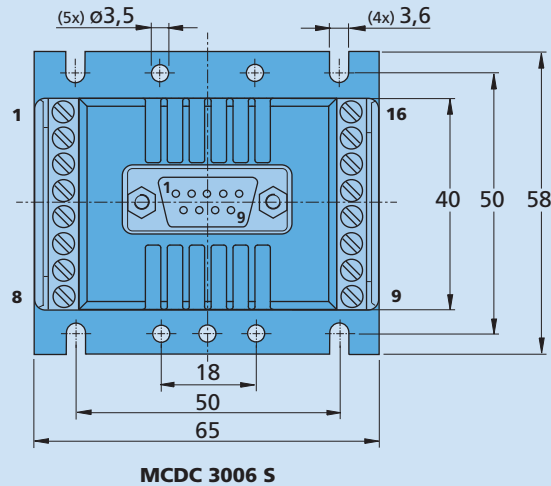

Scale reduced

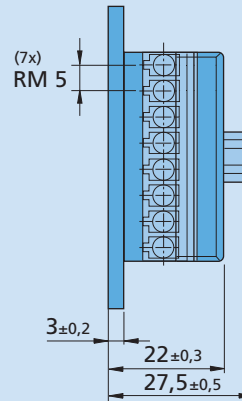

MCDC 3006 S

Options and connection information

Example product designation: **MCDC 3006 S RS 3085**

Option	Type	Description	Connection	
3085	Supply	Separate power supply for motor and electronics	No. Function	No. Function
			1 TxD / CAN_H	9 5. In
			2 RxD / CAN_L	10 4. In
			3 AGND	11 Ch A
			4 Fault	12 Ch B
			5 AnIn	13 U _{CC}
			6 U _B	14 SGND
			7 GND	15 Mot +
			8 3. In	16 Mot -
			D-SUB connector	
			RS-232	
			No. Function	CAN
			2 RxD	2 CAN_L
			3 TxD	3 GND
			5 GND	5 -
			7 -	7 CAN_H
			Note: For details on the connection assignment, see device manual MC.	

Product combination

DC-Motors	Cables / Accessories
1741 ... CXR 2224 ... SR 2230 ... S 2232 ... SR 2233 ... S 2237 ... CXR 2342 ... CR 2642 ... CR 2642 ... CXR 2657 ... CR 2657 ... CXR 2668 ... CR 3242 ... CR 3257 ... CR 3272 ... CR 3863 ... CR 3890 ... CR	To view our large range of accessory parts, please refer to the „Accessories“ chapter.

Motion Controllers

V2.5, 4-Quadrant PWM
with RS232 or CAN interface

MCBL 3002 P

Values at 22°C		MCBL 3002 P	
Power supply electronic	U_B/U_{EL}	8 ... 30	V DC
Power supply motor ¹⁾	$-U_B$	0 ... 30	V DC
PWM switching frequency	f_{PWM}	78,12	kHz
Efficiency electronic	η	95	%
Max. continuous output current	I_{cont}	2	A
Max. peak output current ²⁾	I_{max}	3	A
Standby current for electronic (at $U_B=24V$)	I_{el}	0,04	A
Operating temperature range		-25 ... +85	°C
Mass		7	g

¹⁾ Only available for option 3085 (separate power supply)

²⁾ S2 mode for max. 5s

Interfaces	MCBL 3002 P RS	MCBL 3002 P CO
Interface	RS232	CAN (CiA)
Protocol	FAULHABER - ASCII	CANopen

Basic features

- Supported sensor systems: analog Hall sensors
- Positioning resolution when using analog Hall sensors as position encoder: 3000 increments per revolution
- Max. 3 digital inputs, max. 1 digital output, 1 analog input. Not all I/Os available depending on wiring
- Setpoint specification via fieldbus, quadrature signal, pulse and direction or analog inputs
- Optional stand-alone operation via application programs with the RS232 interface version

Range of functions

Operating modes (RS Versions)	Position, speed and torque control with setpoint specification via interface or analog. Position control with Gearing Mode or stepper motor operation. Operation as Servo Amplifier in voltage controller mode
Operating modes (CO Version)	Profile Position Mode (PP), Profile Velocity Mode (PV), Homing Mode. Cyclic Synchronous Position Mode (CSP) acc. to IEC 61800-7-201 or IEC 61800-7-301.
Speed range for brushless motors with number of pole pairs 1	5 min ⁻¹ ... 30 000 min ⁻¹ (with sinus commutation)
Application programs	Available in versions with RS232 interface
Additional functions	Overload protection for electronics and motor, self-protection from overheating, over-voltage protection in generator mode.
Indicator	Trace as logger
Motor types	Brushless DC-motors with analog Hall sensors and number of pole pairs 1 or 2

Dimensional drawing

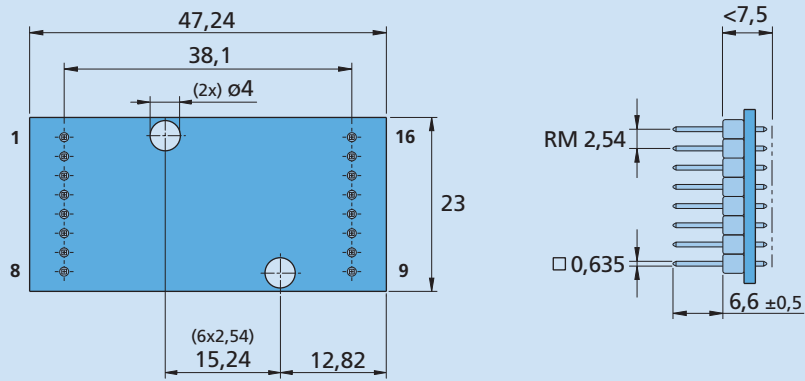

MCBL 3002 P

Options and connection information

Example product designation: **MCBL 3002 P RS 3085**

Option	Type	Description	Connection			
			No.	Function		
3085	Supply	Separate power supply for motor and electronics	1	TxD / CAN_H	9	Sensor A
			2	RxD / CAN_L	10	Sensor B
			3	AGND	11	Sensor C
			4	Fault	12	U _{CC}
			5	AnIn	13	SGND
			6	U _B	14	Motor A
			7	GND	15	Motor B
			8	3. In	16	Motor C

Note: For details on the connection assignment, see device manual MC.

Product combination

Brushless DC-Motors	Cables / Accessories
0620 ... B 1218 ... B 1226 ... B 1628 ... B 2036 ... B 2232 ... BX4 2250 ... BX4 2444 ... B 3056 ... B 3242 ... BX4	To view our large range of accessory parts, please refer to the „Accessories“ chapter.

Motion Controllers

V2.5, 4-Quadrant PWM
with RS232 or CAN interface

MCBL 3002 F

Values at 22°C		MCBL 3002 F	
Power supply electronic	U_B/U_{EL}	8 ... 30	V DC
Power supply motor ¹⁾	$-U_B$	0 ... 30	V DC
PWM switching frequency	f_{PWM}	78,12	kHz
Efficiency electronic	η	95	%
Max. continuous output current	I_{cont}	2	A
Max. peak output current ²⁾	I_{max}	3	A
Standby current for electronic (at $U_B=24V$)	I_{el}	0,04	A
Operating temperature range		-25 ... +85	°C
Housing material		Hotmelt	
Mass		13	g

¹⁾ Only available for option 3085 (separate power supply)

²⁾ S2 mode for max. 5s

Interfaces	MCBL 3002 F RS	MCBL 3002 F CO
Interface	RS232	CAN (CiA)
Protocol	FAULHABER - ASCII	CANopen

Basic features

- Supported sensor systems: analog Hall sensors
- Positioning resolution when using analog Hall sensors as position encoder: 3000 increments per revolution
- Max. 3 digital inputs, max. 1 digital output, 1 analog input. Not all I/Os available depending on wiring
- Setpoint specification via fieldbus, quadrature signal, pulse and direction or analog inputs
- Optional stand-alone operation via application programs with the RS232 interface version

Range of functions

Operating modes (RS Versions)	Position, speed and torque control with setpoint specification via interface or analog. Position control with Gearing Mode or stepper motor operation. Operation as Servo Amplifier in voltage controller mode
Operating modes (CO Version)	Profile Position Mode (PP), Profile Velocity Mode (PV), Homing Mode. Cyclic Synchronous Position Mode (CSP) acc. to IEC 61800-7-201 or IEC 61800-7-301.
Speed range for brushless motors with number of pole pairs 1	5 min ⁻¹ ... 30 000 min ⁻¹ (with sinus commutation)
Application programs	Available in versions with RS232 interface
Additional functions	Overload protection for electronics and motor, self-protection from overheating, over-voltage protection in generator mode.
Indicator	Trace as logger
Motor types	Brushless DC-motors with analog Hall sensors and number of pole pairs 1 or 2

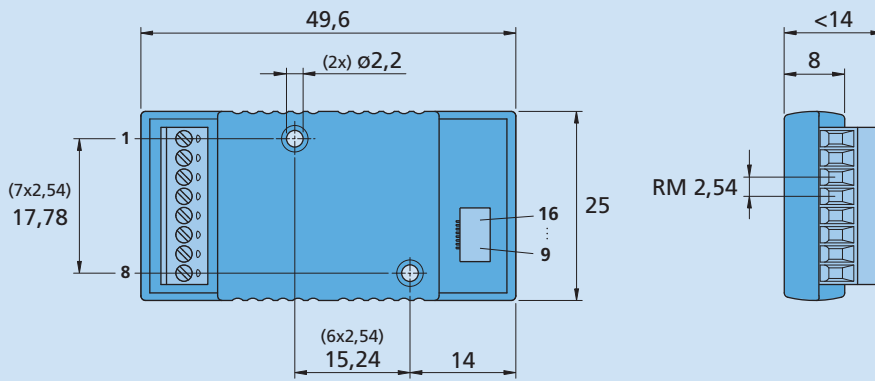
Dimensional drawing

MCBL 3002 F
Connector Information
LIF-Connector 8-pole

Options and connection information

 Example product designation: **MCBL 3002 F RS 3085**

Option	Type	Description	Connection	
			No. Function	No. Function
3085	Supply	Separate power supply for motor and electronics	1 TxD / CAN_H	9 Sensor A
			2 RxD / CAN_L	10 Sensor B
			3 AGND	11 Sensor C
			4 Fault	12 U _{cc}
			5 AnIn	13 SGND
			6 U _B	14 Motor A
			7 GND	15 Motor B
			8 3. In	16 Motor C

Note: For details on the connection assignment, see device manual MC.

Product combination

Brushless DC-Motors	Cables / Accessories
0620 ... B	To view our large range of accessory parts, please refer to the „Accessories“ chapter.

Motion Controllers

V2.5, 4-Quadrant PWM
with RS232 or CAN interface

MCBL 3002 S

Values at 22°C		MCBL 3002 S	
Power supply electronic	U_B/U_{EL}	8 ... 30	V DC
Power supply motor ¹⁾	$-U_B$	0 ... 30	V DC
PWM switching frequency	f_{PWM}	78,12	kHz
Efficiency electronic	η	95	%
Max. continuous output current	I_{cont}	2	A
Max. peak output current ²⁾	I_{max}	3	A
Standby current for electronic (at $U_B=24V$)	I_{el}	0,04	A
Operating temperature range		-25 ... +85	°C
Housing material		Hotmelt	
Mass		16	g

¹⁾ Only available for option 3085 (separate power supply)

²⁾ S2 mode for max. 5s

Interfaces	MCBL 3002 S RS	MCBL 3002 S CO
Interface	RS232	CAN (CiA)
Protocol	FAULHABER - ASCII	CANopen

Basic features

- Supported sensor systems: analog Hall sensors
- Positioning resolution when using analog Hall sensors as position encoder: 3000 increments per revolution
- Max. 3 digital inputs, max. 1 digital output, 1 analog input. Not all I/Os available depending on wiring
- Setpoint specification via fieldbus, quadrature signal, pulse and direction or analog inputs
- Optional stand-alone operation via application programs with the RS232 interface version

Range of functions

Operating modes (RS Versions)	Position, speed and torque control with setpoint specification via interface or analog. Position control with Gearing Mode or stepper motor operation. Operation as Servo Amplifier in voltage controller mode
Operating modes (CO Version)	Profile Position Mode (PP), Profile Velocity Mode (PV), Homing Mode. Cyclic Synchronous Position Mode (CSP) acc. to IEC 61800-7-201 or IEC 61800-7-301.
Speed range for brushless motors with number of pole pairs 1	5 min ⁻¹ ... 30 000 min ⁻¹ (with sinus commutation)
Application programs	Available in versions with RS232 interface
Additional functions	Overload protection for electronics and motor, self-protection from overheating, over-voltage protection in generator mode.
Indicator	Trace as logger
Motor types	Brushless DC-motors with analog Hall sensors and number of pole pairs 1 or 2

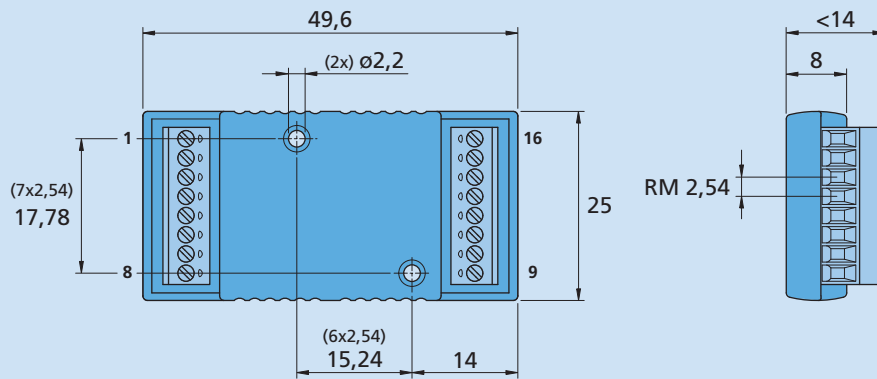
Dimensional drawing

MCBL 3002 S
Options and connection information

 Example product designation: **MCBL 3002 S RS 3085**

Option	Type	Description	Connection	
			No. Function	No. Function
3085	Supply	Separate power supply for motor and electronics	1 TxD / CAN_H	9 Sensor A
			2 RxD / CAN_L	10 Sensor B
			3 AGND	11 Sensor C
			4 Fault	12 U _{cc}
			5 AnIn	13 SGND
			6 U _B	14 Motor A
			7 GND	15 Motor B
			8 3. In	16 Motor C

Note: For details on the connection assignment, see device manual MC.

Product combination

Brushless DC-Motors	Cables / Accessories
1218 ... B 1226 ... B 1628 ... B 2036 ... B 2232 ... BX4 2250 ... BX4 2444 ... B 3056 ... B 3242 ... BX4	To view our large range of accessory parts, please refer to the „Accessories“ chapter.

Motion Controllers

V2.5, 4-Quadrant PWM
with RS232 or CAN interface

MCBL 3003 P

Values at 22°C		MCBL 3003 P	
Power supply electronic	U_B/U_{EL}	12 ... 30	V DC
Power supply motor ¹⁾	$-U_B$	0 ... 30	V DC
PWM switching frequency	f_{PWM}	78,12	kHz
Efficiency electronic	η	95	%
Max. continuous output current	I_{cont}	3	A
Max. peak output current ²⁾	I_{max}	10	A
Standby current for electronic (at $U_B=24V$)	I_{el}	0,06	A
Operating temperature range		-40 ... +85	°C
Mass		18	g

¹⁾ Only available for option 3085 (separate power supply)

²⁾ S2 mode for max. 2s

Interfaces	MCBL 3003 P RS	MCBL 3003 P CO
Interface	RS232	CAN (CiA)
Protocol	FAULHABER - ASCII	CANopen

Basic features

- Supported sensor systems: analog Hall sensors
- Positioning resolution when using analog Hall sensors as position encoder: 3000 increments per revolution
- Max. 3 digital inputs, max. 1 digital output, 1 analog input. Not all I/Os available depending on wiring
- Setpoint specification via fieldbus, quadrature signal, pulse and direction or analog inputs
- Optional stand-alone operation via application programs with the RS232 interface version

Range of functions

Operating modes (RS Versions)	Position, speed and torque control with setpoint specification via interface or analog. Position control with Gearing Mode or stepper motor operation. Operation as Servo Amplifier in voltage controller mode
Operating modes (CO Version)	Profile Position Mode (PP), Profile Velocity Mode (PV), Homing Mode.
Speed range for brushless motors with number of pole pairs 1	5 min ⁻¹ ... 30 000 min ⁻¹ (with sinus commutation)
Application programs	Available in versions with RS232 interface
Additional functions	Overload protection for electronics and motor, self-protection from overheating, over-voltage protection in generator mode.
Indicator	Trace as logger
Motor types	Brushless DC-motors with analog Hall sensors and number of pole pairs 1 or 2

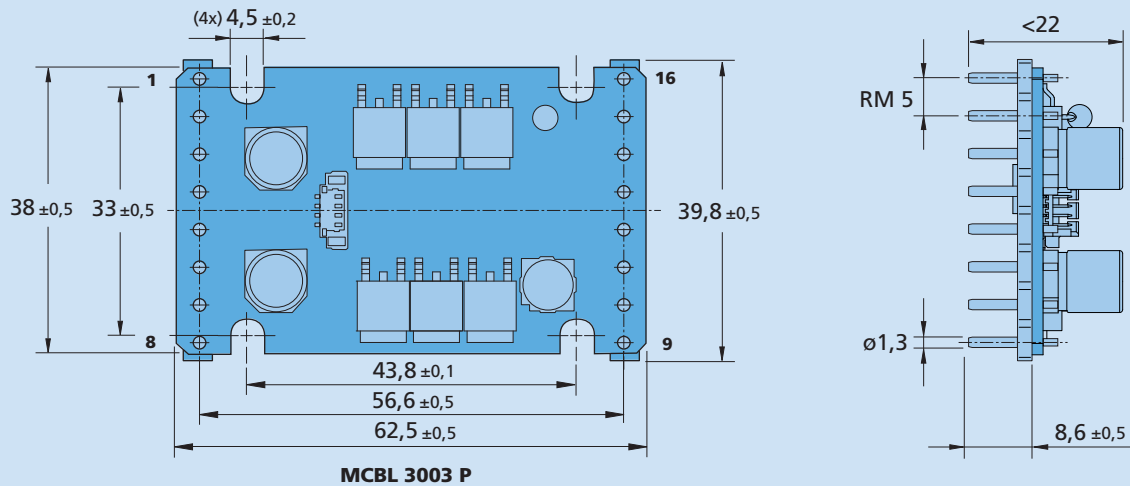
Dimensional drawing

Options and connection information

 Example product designation: **MCBL 3003 P RS 3085**

Option	Type	Description	Connection	
			No.	Function
3085	Supply	Separate power supply for motor and electronics	1	TxD / CAN_H
			2	RxD / CAN_L
			3	AGND
			4	Fault
			5	AnIn
			6	U_B
			7	GND
			8	3. In
			9	Sensor A
			10	Sensor B
			11	Sensor C
			12	U_{CC}
			13	SGND
			14	Motor A
			15	Motor B
			16	Motor C

Max. recommended current for continuous operation:
3A (at 22 °C ambient temperature)

CAUTION: Thermal shutdown is NOT guaranteed!

Note: For details on the connection assignment, see device manual MC.

Product combination

Brushless DC-Motors	Cables / Accessories
0620 ... B 1218 ... B 1226 ... B 1628 ... B 2036 ... B 2057 ... B 2232 ... BX4 2250 ... BX4 2444 ... B 3056 ... B 3242 ... BX4 3268 ... BX4 3564 ... B	To view our large range of accessory parts, please refer to the „Accessories“ chapter.

Motion Controllers

V2.5, 4-Quadrant PWM
with RS232 or CAN interface

MCBL 3006 S

Values at 22°C		MCBL 3006 S	
Power supply electronic	U_B/U_{EL}	12 ... 30	V DC
Power supply motor ¹⁾	$-U_B$	0 ... 30	V DC
PWM switching frequency	f_{PWM}	78,12	kHz
Efficiency electronic	η	95	%
Max. continuous output current	I_{cont}	6	A
Max. peak output current ²⁾	I_{max}	10	A
Standby current for electronic (at $U_B=24V$)	I_{el}	0,06	A
Operating temperature range		-40 ... +85	°C
Housing material		zinc, black coated	
Mass		160	g

¹⁾ Only available for option 3085 (separate power supply)

²⁾ S2 mode for max. 9s

Interfaces	MCBL 3006 S RS	MCBL 3006 S CO
Interface	RS232	CAN (CiA)
Protocol	FAULHABER - ASCII	CANopen

Basic features

- Supported sensor systems: analog Hall sensors
- Positioning resolution when using analog Hall sensors as position encoder: 3000 increments per revolution
- Max. 3 digital inputs, max. 1 digital output, 1 analog input. Not all I/Os available depending on wiring
- Setpoint specification via fieldbus, quadrature signal, pulse and direction or analog inputs
- Optional stand-alone operation via application programs with the RS232 interface version

Range of functions

Operating modes (RS Versions)	Position, speed and torque control with setpoint specification via interface or analog. Position control with Gearing Mode or stepper motor operation. Operation as Servo Amplifier in voltage controller mode
Operating modes (CO Version)	Profile Position Mode (PP), Profile Velocity Mode (PV), Homing Mode.
Speed range for brushless motors with number of pole pairs 1	5 min ⁻¹ ... 30 000 min ⁻¹ (with sinus commutation)
Application programs	Available in versions with RS232 interface
Additional functions	Overload protection for electronics and motor, self-protection from overheating, over-voltage protection in generator mode.
Indicator	Trace as logger
Motor types	Brushless DC-motors with analog Hall sensors and number of pole pairs 1 or 2

Dimensional drawing

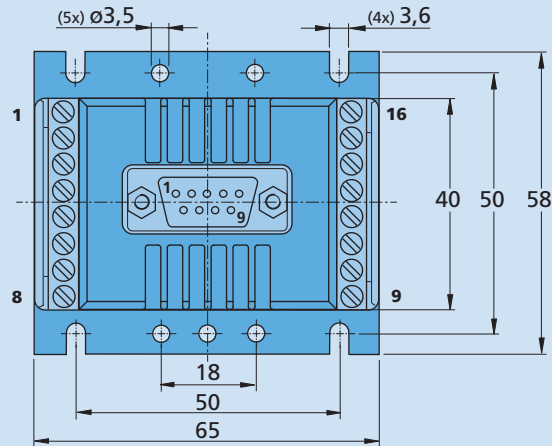

MCBL 3006 S

Scale reduced

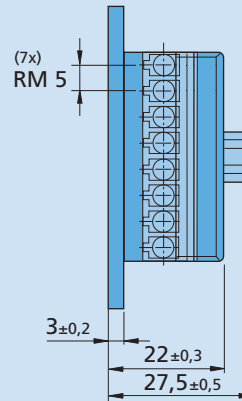

Options and connection information

Example product designation: **MCBL 3006 S RS 3085**

Option	Type	Description	Connection	
3085	Supply	Separate power supply for motor and electronics	No. Function	No. Function
			1 TxD / CAN_H	9 Sensor A
			2 RxD / CAN_L	10 Sensor B
			3 AGND	11 Sensor C
			4 Fault	12 U _{cc}
			5 AnIn	13 SGND
			6 U _B	14 Motor A
			7 GND	15 Motor B
			8 3. In	16 Motor C
			D-SUB connector	
			RS-232	
			No. Function	CAN
			2 RxD	2 CAN_L
			3 TxD	3 GND
			5 GND	5 -
			7 -	7 CAN_H
			Note: For details on the connection assignment, see device manual MC.	

Product combination

Brushless DC-Motors	Cables / Accessories
2057 ... B 2232 ... BX4 2250 ... BX4 2444 ... B 3056 ... B 3242 ... BX4 3268 ... BX4 3564 ... B 4490 ... B 4490 ... BS	To view our large range of accessory parts, please refer to the „Accessories“ chapter.

Motion Controllers

V2.5, 4-Quadrant PWM
with RS232 or CAN interface

MCBL 3002 P AES

Values at 22°C		MCBL 3002 P AES	
Power supply electronic	U_B/U_{EL}	8 ... 30	V DC
Power supply motor ¹⁾	$-U_B$	0 ... 30	V DC
PWM switching frequency	f_{PWM}	78,12	kHz
Efficiency electronic	η	95	%
Max. continuous output current	I_{cont}	2	A
Max. peak output current ²⁾	I_{max}	3	A
Standby current for electronic (at $U_B=24V$)	I_{el}	0,04	A
Operating temperature range		-25 ... +85	°C
Mass		7	g

¹⁾ Only available for option 3085 (separate power supply)

²⁾ S2 mode for max. 5s

Interfaces	MCBL 3002 P AES RS	MCBL 3002 P AES CO
Interface	RS232	CAN (CiA)
Protocol	FAULHABER - ASCII	CANopen

Basic features

- Supported sensor systems: single-turn absolute encoders
- Positioning resolution when using absolute encoders as position encoder: 4096 steps per revolution
- Max. 3 digital inputs, max. 1 digital output, 1 analog input. Not all I/Os available depending on wiring
- Setpoint specification via fieldbus, quadrature signal, pulse and direction or analog inputs
- Optional stand-alone operation via application programs with the RS232 interface version

Range of functions

Operating modes (RS Versions)	Position, speed and torque control with setpoint specification via interface or analog. Position control with Gearing Mode or stepper motor operation. Operation as Servo Amplifier in voltage controller mode
Operating modes (CO Version)	Profile Position Mode (PP), Profile Velocity Mode (PV), Homing Mode. Cyclic Synchronous Position Mode (CSP) acc. to IEC 61800-7-201 or IEC 61800-7-301.
Speed range for brushless motors with number of pole pairs 1	5 min ⁻¹ ... 30 000 min ⁻¹ (with sinus commutation)
Application programs	Available in versions with RS232 interface
Additional functions	Overload protection for electronics and motor, self-protection from overheating, over-voltage protection in generator mode.
Indicator	Trace as logger
Motor types	Brushless DC-motors with absolute encoders and number of pole pairs 1 or 2

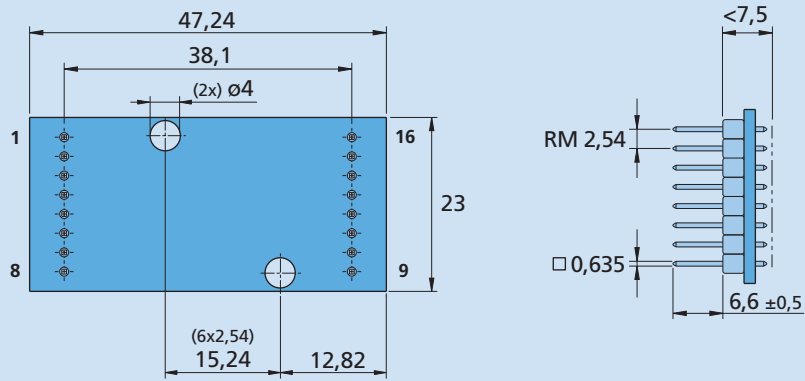
Dimensional drawing

MCBL 3002 P AES
Options and connection information

 Example product designation: **MCBL 3002 P AES RS 3085**

Option	Type	Description	Connection	
			No. Function	No. Function
3085	Supply	Separate power supply for motor and electronics	1 TxD / CAN_H	9 Sensor A / DATA
			2 RxD / CAN_L	10 Sensor B / \overline{CS}
			3 AGND	11 Sensor C / CLK
			4 Fault	12 U_{CC}
			5 AnIn	13 SGND
			6 U_B	14 Motor A
			7 GND	15 Motor B
			8 3. In	16 Motor C

Note: For details on the connection assignment, see device manual MC.

Product combination

Brushless DC-Motors	Cables / Accessories
0824 ... B 1028 ... B 2232 ... BX4 2250 ... BX4 3242 ... BX4	To view our large range of accessory parts, please refer to the „Accessories“ chapter.

Motion Controllers

V2.5, 4-Quadrant PWM
with RS232 or CAN interface

MCBL 3002 F AES

Values at 22°C	MCBL 3002 F AES		
Power supply electronic	U_B/U_{EL}	8 ... 30	V DC
Power supply motor ¹⁾	$-U_B$	0 ... 30	V DC
PWM switching frequency	f_{PWM}	78,12	kHz
Efficiency electronic	η	95	%
Max. continuous output current	I_{cont}	2	A
Max. peak output current ²⁾	I_{max}	3	A
Standby current for electronic (at $U_B=24V$)	I_{el}	0,04	A
Operating temperature range		-25 ... +85	°C
Housing material		Hotmelt	
Mass		13	g

¹⁾ Only available for option 3085 (separate power supply)

²⁾ S2 mode for max. 5s

Interfaces	MCBL 3002 F AES RS	MCBL 3002 F AES CO
Interface	RS232	CAN (CiA)
Protocol	FAULHABER - ASCII	CANopen

Basic features

- Supported sensor systems: single-turn absolute encoders
- Positioning resolution when using absolute encoders as position encoder: 4096 steps per revolution
- Max. 3 digital inputs, max. 1 digital output, 1 analog input. Not all I/Os available depending on wiring
- Setpoint specification via fieldbus, quadrature signal, pulse and direction or analog inputs
- Optional stand-alone operation via application programs with the RS232 interface version

Range of functions

Operating modes (RS Versions)	Position, speed and torque control with setpoint specification via interface or analog. Position control with Gearing Mode or stepper motor operation. Operation as Servo Amplifier in voltage controller mode
Operating modes (CO Version)	Profile Position Mode (PP), Profile Velocity Mode (PV), Homing Mode. Cyclic Synchronous Position Mode (CSP) acc. to IEC 61800-7-201 or IEC 61800-7-301.
Speed range for brushless motors with number of pole pairs 1	5 min ⁻¹ ... 30 000 min ⁻¹ (with sinus commutation)
Application programs	Available in versions with RS232 interface
Additional functions	Overload protection for electronics and motor, self-protection from overheating, over-voltage protection in generator mode.
Indicator	Trace as logger
Motor types	Brushless DC-motors with absolute encoders and number of pole pairs 1 or 2

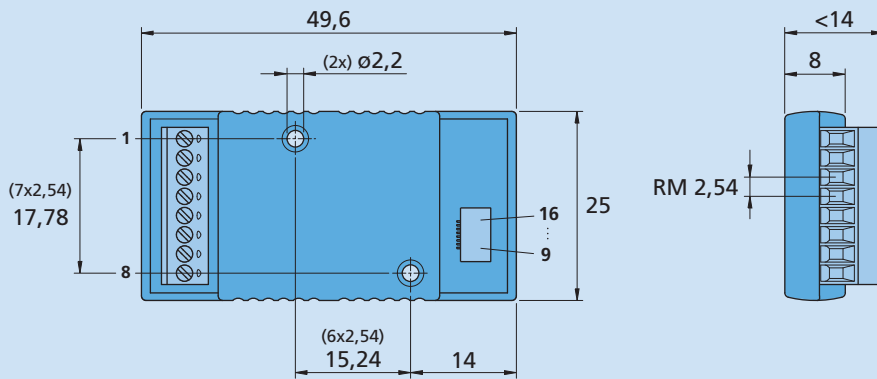
Dimensional drawing

MCBL 3002 F AES
Connector Information
LIF-Connector 8-pole

Options and connection information

 Example product designation: **MCBL 3002 F AES RS 3085**

Option	Type	Description	Connection	
			No. Function	No. Function
3085	Supply	Separate power supply for motor and electronics	1 TxD / CAN_H	9 Sensor A / DATA
			2 RxD / CAN_L	10 Sensor B / \overline{CS}
			3 AGND	11 Sensor C / CLK
			4 Fault	12 U_{cc}
			5 AnIn	13 SGND
			6 U_B	14 Motor A
			7 GND	15 Motor B
			8 3. In	16 Motor C

Note: For details on the connection assignment, see device manual MC.

Product combination

Brushless DC-Motors	Cables / Accessories
0824 ... B 1028 ... B	To view our large range of accessory parts, please refer to the „Accessories“ chapter.

Motion Controllers

V2.5, 4-Quadrant PWM
with RS232 or CAN interface

MCBL 3002 S AES

Values at 22°C		MCBL 3002 S AES	
Power supply electronic	U_B/U_{EL}	8 ... 30	V DC
Power supply motor ¹⁾	$-U_B$	0 ... 30	V DC
PWM switching frequency	f_{PWM}	78,12	kHz
Efficiency electronic	η	95	%
Max. continuous output current	I_{cont}	2	A
Max. peak output current ²⁾	I_{max}	3	A
Standby current for electronic (at $U_B=24V$)	I_{el}	0,04	A
Operating temperature range		-25 ... +85	°C
Housing material		Hotmelt	
Mass		16	g

¹⁾ Only available for option 3085 (separate power supply)

²⁾ S2 mode for max. 5s

Interfaces	MCBL 3002 S AES RS	MCBL 3002 S AES CO
Interface	RS232	CAN (CiA)
Protocol	FAULHABER - ASCII	CANopen

Basic features

- Supported sensor systems: single-turn absolute encoders
- Positioning resolution when using absolute encoders as position encoder: 4096 steps per revolution
- Max. 3 digital inputs, max. 1 digital output, 1 analog input. Not all I/Os available depending on wiring
- Setpoint specification via fieldbus, quadrature signal, pulse and direction or analog inputs
- Optional stand-alone operation via application programs with the RS232 interface version

Range of functions

Operating modes (RS Versions)	Position, speed and torque control with setpoint specification via interface or analog. Position control with Gearing Mode or stepper motor operation. Operation as Servo Amplifier in voltage controller mode
Operating modes (CO Version)	Profile Position Mode (PP), Profile Velocity Mode (PV), Homing Mode. Cyclic Synchronous Position Mode (CSP) acc. to IEC 61800-7-201 or IEC 61800-7-301.
Speed range for brushless motors with number of pole pairs 1	5 min ⁻¹ ... 30 000 min ⁻¹ (with sinus commutation)
Application programs	Available in versions with RS232 interface
Additional functions	Overload protection for electronics and motor, self-protection from overheating, over-voltage protection in generator mode.
Indicator	Trace as logger
Motor types	Brushless DC-motors with absolute encoders and number of pole pairs 1 or 2

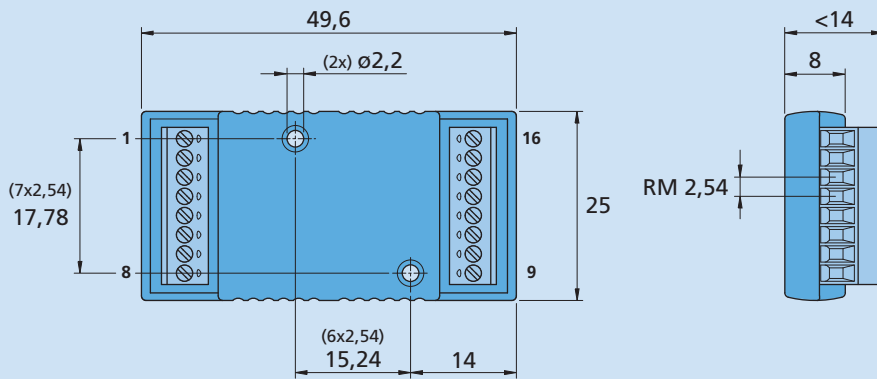
Dimensional drawing

MCBL 3002 S AES
Options and connection information

 Example product designation: **MCBL 3002 S AES RS 3085**

Option	Type	Description	Connection	
			No. Function	No. Function
3085	Supply	Separate power supply for motor and electronics	1 TxD / CAN_H	9 Sensor A / DATA
			2 RxD / CAN_L	10 Sensor B / \overline{CS}
			3 AGND	11 Sensor C / CLK
			4 Fault	12 U_{CC}
			5 AnIn	13 SGND
			6 U_B	14 Motor A
			7 GND	15 Motor B
			8 3. In	16 Motor C

Note: For details on the connection assignment, see device manual MC.

Product combination

Brushless DC-Motors	Cables / Accessories
2232 ... BX4 2250 ... BX4 3242 ... BX4	To view our large range of accessory parts, please refer to the „Accessories“ chapter.

Motion Controllers

V2.5, 4-Quadrant PWM
with RS232 or CAN interface

MCBL 3003 P AES

Values at 22°C		MCBL 3003 P AES	
Power supply electronic	U_B/U_{EL}	12 ... 30	V DC
Power supply motor ¹⁾	$-U_B$	0 ... 30	V DC
PWM switching frequency	f_{PWM}	78,12	kHz
Efficiency electronic	η	95	%
Max. continuous output current	I_{cont}	3	A
Max. peak output current ²⁾	I_{max}	10	A
Standby current for electronic (at $U_B=24V$)	I_{el}	0,06	A
Operating temperature range		-40 ... +85	°C
Mass		18	g

¹⁾ Only available for option 3085 (separate power supply)

²⁾ S2 mode for max. 2s

Interfaces	MCBL 3003 P AES RS	MCBL 3003 P AES CO
Interface	RS232	CAN (CiA)
Protocol	FAULHABER - ASCII	CANopen

Basic features

- Supported sensor systems: single-turn absolute encoders
- Positioning resolution when using absolute encoders as position encoder: 4096 steps per revolution
- Max. 3 digital inputs, max. 1 digital output, 1 analog input. Not all I/Os available depending on wiring
- Setpoint specification via fieldbus, quadrature signal, pulse and direction or analog inputs
- Optional stand-alone operation via application programs with the RS232 interface version

Range of functions

Operating modes (RS Versions)	Position, speed and torque control with setpoint specification via interface or analog. Position control with Gearing Mode or stepper motor operation. Operation as Servo Amplifier in voltage controller mode
Operating modes (CO Version)	Profile Position Mode (PP), Profile Velocity Mode (PV), Homing Mode.
Speed range for brushless motors with number of pole pairs 1	5 min ⁻¹ ... 30 000 min ⁻¹ (with sinus commutation)
Application programs	Available in versions with RS232 interface
Additional functions	Overload protection for electronics and motor, self-protection from overheating, over-voltage protection in generator mode.
Indicator	Trace as logger
Motor types	Brushless DC-motors with absolute encoders and number of pole pairs 1 or 2

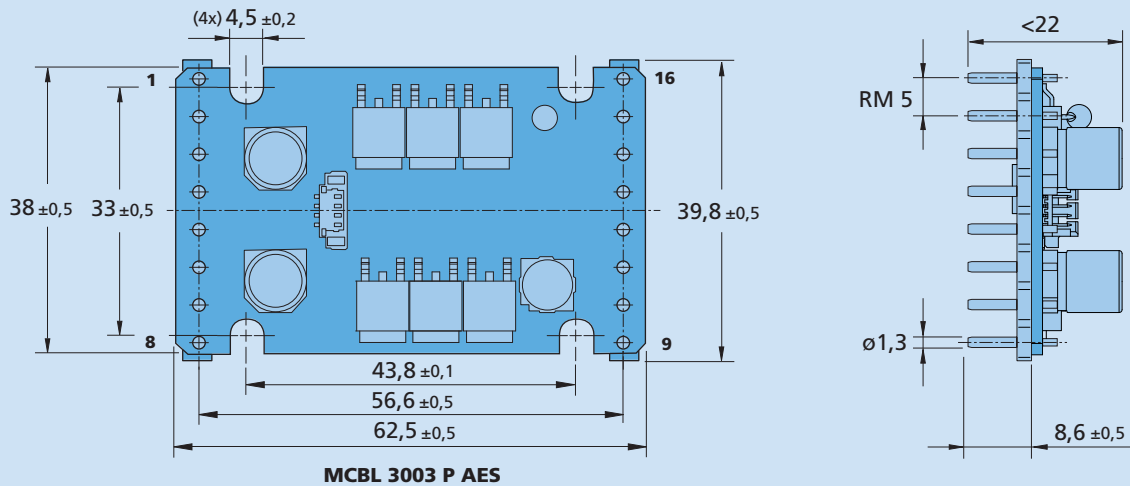
Dimensional drawing

Options and connection information

 Example product designation: **MCBL 3003 P AES RS 3085**

Option	Type	Description	Connection			
			No.	Function	No.	Function
3085	Supply	Separate power supply for motor and electronics	1	TxD / CAN_H	9	Sensor A / DATA
			2	RxD / CAN_L	10	Sensor B / CS
			3	AGND	11	Sensor C / CLK
			4	Fault	12	U_{CC}
			5	AnIn	13	SGND
			6	U_B	14	Motor A
			7	GND	15	Motor B
			8	3. In	16	Motor C

Max. recommended current for continuous operation:
3A (at 22 °C ambient temperature)

CAUTION: Thermal shutdown is NOT guaranteed!

Note: For details on the connection assignment, see device manual MC.

Product combination

Brushless DC-Motors	Cables / Accessories
0824 ... B 1028 ... B 2232 ... BX4 2250 ... BX4 3242 ... BX4 3268 ... BX4	To view our large range of accessory parts, please refer to the „Accessories“ chapter.

Motion Controllers

V2.5, 4-Quadrant PWM
with RS232 or CAN interface

MCBL 3006 S AES

Values at 22°C		MCBL 3006 S AES	
Power supply electronic	U_B/U_{EL}	12 ... 30	V DC
Power supply motor ¹⁾	$-U_B$	0 ... 30	V DC
PWM switching frequency	f_{PWM}	78,12	kHz
Efficiency electronic	η	95	%
Max. continuous output current	I_{cont}	6	A
Max. peak output current ²⁾	I_{max}	10	A
Standby current for electronic (at $U_B=24V$)	I_{el}	0,06	A
Operating temperature range		-40 ... +85	°C
Housing material		zinc, black coated	
Mass		160	g

¹⁾ Only available for option 3085 (separate power supply)

²⁾ S2 mode for max. 9s

Interfaces	MCBL 3006 S AES RS	MCBL 3006 S AES CO
Interface	RS232	CAN (CiA)
Protocol	FAULHABER - ASCII	CANopen

Basic features

- Supported sensor systems: single-turn absolute encoders
- Positioning resolution when using absolute encoders as position encoder: 4096 steps per revolution
- Max. 3 digital inputs, max. 1 digital output, 1 analog input. Not all I/Os available depending on wiring
- Setpoint specification via fieldbus, quadrature signal, pulse and direction or analog inputs
- Optional stand-alone operation via application programs with the RS232 interface version

Range of functions

Operating modes (RS Versions)	Position, speed and torque control with setpoint specification via interface or analog. Position control with Gearing Mode or stepper motor operation. Operation as Servo Amplifier in voltage controller mode
Operating modes (CO Version)	Profile Position Mode (PP), Profile Velocity Mode (PV), Homing Mode.
Speed range for brushless motors with number of pole pairs 1	5 min ⁻¹ ... 30 000 min ⁻¹ (with sinus commutation)
Application programs	Available in versions with RS232 interface
Additional functions	Overload protection for electronics and motor, self-protection from overheating, over-voltage protection in generator mode.
Indicator	Trace as logger
Motor types	Brushless DC-motors with absolute encoders and number of pole pairs 1 or 2

Dimensional drawing

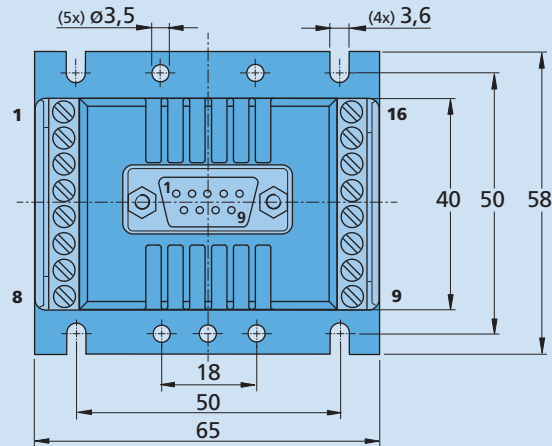

Scale reduced

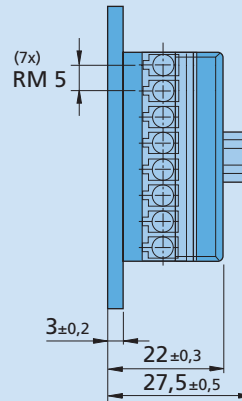

MCBL 3006 S AES

Options and connection information

Example product designation: **MCBL 3006 S AES RS 3085**

Option	Type	Description	Connection	
3085	Supply	Separate power supply for motor and electronics	No. Function	No. Function
			1 TxD / CAN_H	9 Sensor A / DATA
			2 RxD / CAN_L	10 Sensor B / CS
			3 AGND	11 Sensor C / CLK
			4 Fault	12 U _{cc}
			5 AnIn	13 SGND
			6 U _B	14 Motor A
			7 GND	15 Motor B
			8 3. In	16 Motor C
			D-SUB connector	
			RS-232	
			No. Function	No. Function
			2 RxD	2 CAN_L
			3 TxD	3 GND
			5 GND	5 -
			7 -	7 CAN_H
			Note: For details on the connection assignment, see device manual MC.	

Product combination

Brushless DC-Motors	Cables / Accessories
2232 ... BX4 2250 ... BX4 3242 ... BX4 3268 ... BX4	To view our large range of accessory parts, please refer to the „Accessories“ chapter.

Motion Controllers

V2.5, 4-Quadrant PWM
with RS232 or CAN interface

MCLM 3002 P

Values at 22°C		MCLM 3002 P	
Power supply electronic	U_B/U_{EL}	8 ... 30	V DC
Power supply motor ¹⁾	$-U_B$	0 ... 30	V DC
PWM switching frequency	f_{PWM}	78,12	kHz
Efficiency electronic	η	95	%
Max. continuous output current	I_{cont}	2	A
Max. peak output current ²⁾	I_{max}	3	A
Standby current for electronic (at $U_B=24V$)	I_{el}	0,04	A
Operating temperature range		-25 ... +85	°C
Mass		7	g

¹⁾ Only available for option 3085 (separate power supply)

²⁾ S2 mode for max. 5s

Interfaces	MCLM 3002 P RS	MCLM 3002 P CO
Interface	RS232	CAN (CiA)
Protocol	FAULHABER - ASCII	CANopen

Basic features

- Operation of brushless linear DC-Servomotors
- Supported sensor systems: analog Hall sensors
- Positioning resolution when using analog Hall sensors as position encoder: 3000 increments per revolution
- Max. 3 digital inputs, max. 1 digital output, 1 analog input. Not all I/Os available depending on wiring
- Setpoint specification via fieldbus, quadrature signal, pulse and direction or analog inputs
- Optional stand-alone operation via application programs with the RS232 interface version

Range of functions

Operating modes (RS Versions)	Position, speed and torque control with setpoint specification via interface or analog. Position control with Gearing Mode or stepper motor operation. Operation as Servo Amplifier in voltage controller mode
Operating modes (CO Version)	Profile Position Mode (PP), Profile Velocity Mode (PV), Homing Mode. Cyclic Synchronous Position Mode (CSP) acc. to IEC 61800-7-201 or IEC 61800-7-301.
Velocity range	2 mm/s ... 10 000 mm/s
Application programs	Available in versions with RS232 interface
Additional functions	Overload protection for electronics and motor, self-protection from overheating, over-voltage protection in generator mode.
Indicator	Trace as logger
Motor types	Brushless Linear DC-Servomotors with analog Hall sensors

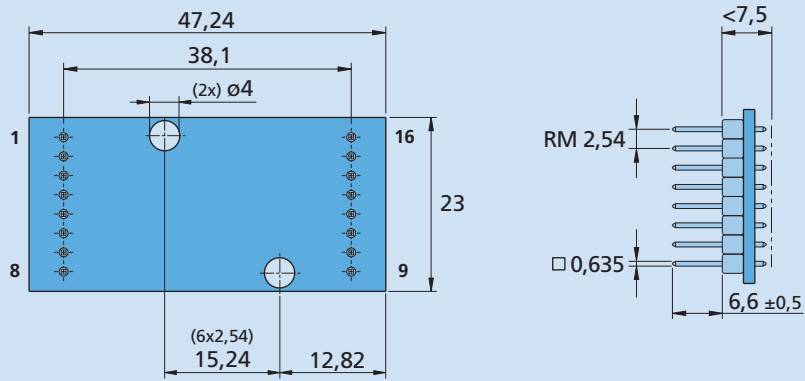
Dimensional drawing

MCLM 3002 P
Options and connection information

 Example product designation: **MCLM 3002 P RS 3085**

Option	Type	Description	Connection	
			No.	Function
3085	Supply	Separate power supply for motor and electronics	1	TxD / CAN_H
			2	RxD / CAN_L
			3	AGND
			4	Fault
			5	AnIn
			6	U_B
			7	GND
			8	3. In
			9	Sensor A
			10	Sensor B
			11	Sensor C
			12	U_{CC}
			13	SGND
			14	Motor A
			15	Motor B
			16	Motor C

Note: For details on the connection assignment, see device manual MC.

Product combination

Linear DC-Servomotors	Cables / Accessories
LM 0830 ... 01 LM 1247 ... 11 LM 1483 ... 11	To view our large range of accessory parts, please refer to the „Accessories“ chapter.

Motion Controllers

V2.5, 4-Quadrant PWM
with RS232 or CAN interface

MCLM 3002 F

Values at 22°C		MCLM 3002 F	
Power supply electronic	U_B/U_{EL}	8 ... 30	V DC
Power supply motor ¹⁾	$-U_B$	0 ... 30	V DC
PWM switching frequency	f_{PWM}	78,12	kHz
Efficiency electronic	η	95	%
Max. continuous output current	I_{cont}	2	A
Max. peak output current ²⁾	I_{max}	3	A
Standby current for electronic (at $U_B=24V$)	I_{el}	0,04	A
Operating temperature range		-25 ... +85	°C
Housing material		Hotmelt	
Mass		13	g

¹⁾ Only available for option 3085 (separate power supply)

²⁾ S2 mode for max. 5s

Interfaces	MCLM 3002 F RS	MCLM 3002 F CO
Interface	RS232	CAN (CiA)
Protocol	FAULHABER - ASCII	CANopen

Basic features

- Operation of brushless linear DC-Servomotors
- Supported sensor systems: analog Hall sensors
- Positioning resolution when using analog Hall sensors as position encoder: 3000 increments per revolution
- Max. 3 digital inputs, max. 1 digital output, 1 analog input. Not all I/Os available depending on wiring
- Setpoint specification via fieldbus, quadrature signal, pulse and direction or analog inputs
- Optional stand-alone operation via application programs with the RS232 interface version

Range of functions

Operating modes (RS Versions)	Position, speed and torque control with setpoint specification via interface or analog. Position control with Gearing Mode or stepper motor operation. Operation as Servo Amplifier in voltage controller mode
Operating modes (CO Version)	Profile Position Mode (PP), Profile Velocity Mode (PV), Homing Mode. Cyclic Synchronous Position Mode (CSP) acc. to IEC 61800-7-201 or IEC 61800-7-301.
Velocity range	2 mm/s ... 10 000 mm/s
Application programs	Available in versions with RS232 interface
Additional functions	Overload protection for electronics and motor, self-protection from overheating, over-voltage protection in generator mode.
Indicator	Trace as logger
Motor types	Brushless Linear DC-Servomotors with analog Hall sensors

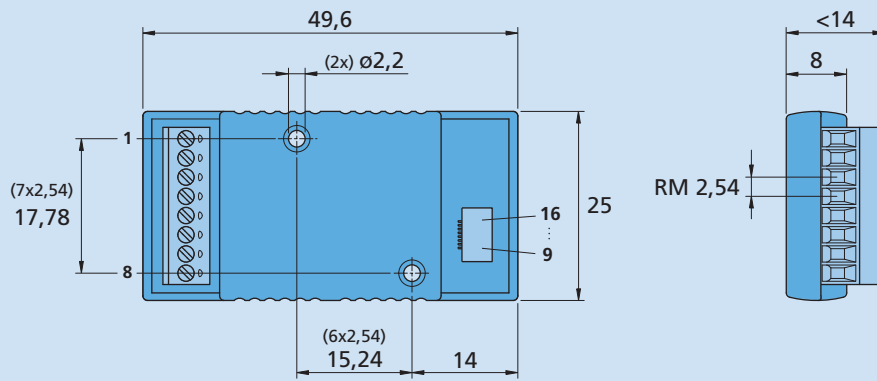
Dimensional drawing

MCLM 3002 F
Connector Information
LIF-Connector 8-pole

Options and connection information

 Example product designation: **MCLM 3002 F RS 3085**

Option	Type	Description	Connection	
			No. Function	No. Function
3085	Supply	Separate power supply for motor and electronics	1 TxD / CAN_H	9 Sensor A
			2 RxD / CAN_L	10 Sensor B
			3 AGND	11 Sensor C
			4 Fault	12 U _{cc}
			5 AnIn	13 SGND
			6 U _B	14 Motor A
			7 GND	15 Motor B
			8 3. In	16 Motor C

Note: For details on the connection assignment, see device manual MC.

Product combination

Linear DC-Servomotors	Cables / Accessories
LM 0830 ... 01	To view our large range of accessory parts, please refer to the „Accessories“ chapter.

Motion Controllers

V2.5, 4-Quadrant PWM
with RS232 or CAN interface

MCLM 3002 S

Values at 22°C		MCLM 3002 S	
Power supply electronic	U_B/U_{EL}	8 ... 30	V DC
Power supply motor ¹⁾	$-U_B$	0 ... 30	V DC
PWM switching frequency	f_{PWM}	78,12	kHz
Efficiency electronic	η	95	%
Max. continuous output current	I_{cont}	2	A
Max. peak output current ²⁾	I_{max}	3	A
Standby current for electronic (at $U_B=24V$)	I_{el}	0,04	A
Operating temperature range		-25 ... +85	°C
Housing material		Hotmelt	
Mass		16	g

¹⁾ Only available for option 3085 (separate power supply)

²⁾ S2 mode for max. 5s

Interfaces	MCLM 3002 S RS	MCLM 3002 S CO
Interface	RS232	CAN (CiA)
Protocol	FAULHABER - ASCII	CANopen

Basic features

- Operation of brushless linear DC-Servomotors
- Supported sensor systems: analog Hall sensors
- Positioning resolution when using analog Hall sensors as position encoder: 3000 increments per revolution
- Max. 3 digital inputs, max. 1 digital output, 1 analog input. Not all I/Os available depending on wiring
- Setpoint specification via fieldbus, quadrature signal, pulse and direction or analog inputs
- Optional stand-alone operation via application programs with the RS232 interface version

Range of functions

Operating modes (RS Versions)	Position, speed and torque control with setpoint specification via interface or analog. Position control with Gearing Mode or stepper motor operation. Operation as Servo Amplifier in voltage controller mode
Operating modes (CO Version)	Profile Position Mode (PP), Profile Velocity Mode (PV), Homing Mode. Cyclic Synchronous Position Mode (CSP) acc. to IEC 61800-7-201 or IEC 61800-7-301.
Velocity range	2 mm/s ... 10 000 mm/s
Application programs	Available in versions with RS232 interface
Additional functions	Overload protection for electronics and motor, self-protection from overheating, over-voltage protection in generator mode.
Indicator	Trace as logger
Motor types	Brushless Linear DC-Servomotors with analog Hall sensors

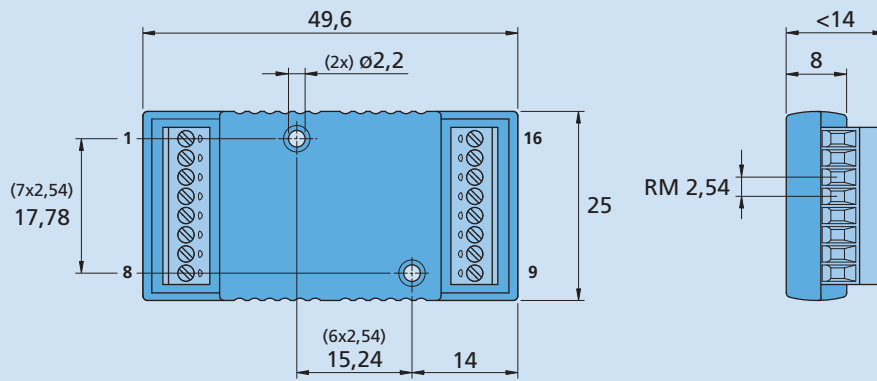
Dimensional drawing

MCLM 3002 S
Options and connection information

 Example product designation: **MCLM 3002 S RS 3085**

Option	Type	Description	Connection	
			No. Function	No. Function
3085	Supply	Separate power supply for motor and electronics	1 TxD / CAN_H	9 Sensor A
			2 RxD / CAN_L	10 Sensor B
			3 AGND	11 Sensor C
			4 Fault	12 U_{cc}
			5 AnIn	13 SGND
			6 U_B	14 Motor A
			7 GND	15 Motor B
			8 3. In	16 Motor C

Note: For details on the connection assignment, see device manual MC.

Product combination

Linear DC-Servomotors	Cables / Accessories
LM 0830 ... 01 LM 1247 ... 11 LM 1483 ... 11	To view our large range of accessory parts, please refer to the „Accessories“ chapter.

Motion Controllers

V2.5, 4-Quadrant PWM
with RS232 or CAN interface

MCLM 3003 P

Values at 22°C		MCLM 3003 P	
Power supply electronic	U_B/U_{EL}	12 ... 30	V DC
Power supply motor ¹⁾	$-/U_B$	0 ... 30	V DC
PWM switching frequency	f_{PWM}	78,12	kHz
Efficiency electronic	η	95	%
Max. continuous output current	I_{cont}	3	A
Max. peak output current ²⁾	I_{max}	10	A
Standby current for electronic (at $U_B=24V$)	I_{el}	0,06	A
Operating temperature range		-40 ... +85	°C
Mass		18	g

¹⁾ Only available for option 3085 (separate power supply)

²⁾ S2 mode for max. 2s

Interfaces	MCLM 3003 P RS	MCLM 3003 P CO
Interface	RS232	CAN (CiA)
Protocol	FAULHABER - ASCII	CANopen

Basic features

- Operation of brushless linear DC-Servomotors
- Supported sensor systems: analog Hall sensors
- Positioning resolution when using analog Hall sensors as position encoder: 3000 increments per revolution
- Max. 3 digital inputs, max. 1 digital output, 1 analog input. Not all I/Os available depending on wiring
- Setpoint specification via fieldbus, quadrature signal, pulse and direction or analog inputs
- Optional stand-alone operation via application programs with the RS232 interface version

Range of functions

Operating modes (RS Versions)	Position, speed and torque control with setpoint specification via interface or analog. Position control with Gearing Mode or stepper motor operation. Operation as Servo Amplifier in voltage controller mode
Operating modes (CO Version)	Profile Position Mode (PP), Profile Velocity Mode (PV), Homing Mode.
Velocity range	2 mm/s ... 10 000 mm/s
Application programs	Available in versions with RS232 interface
Additional functions	Overload protection for electronics and motor, self-protection from overheating, over-voltage protection in generator mode.
Indicator	Trace as logger
Motor types	Brushless Linear DC-Servomotors with analog Hall sensors

Dimensional drawing

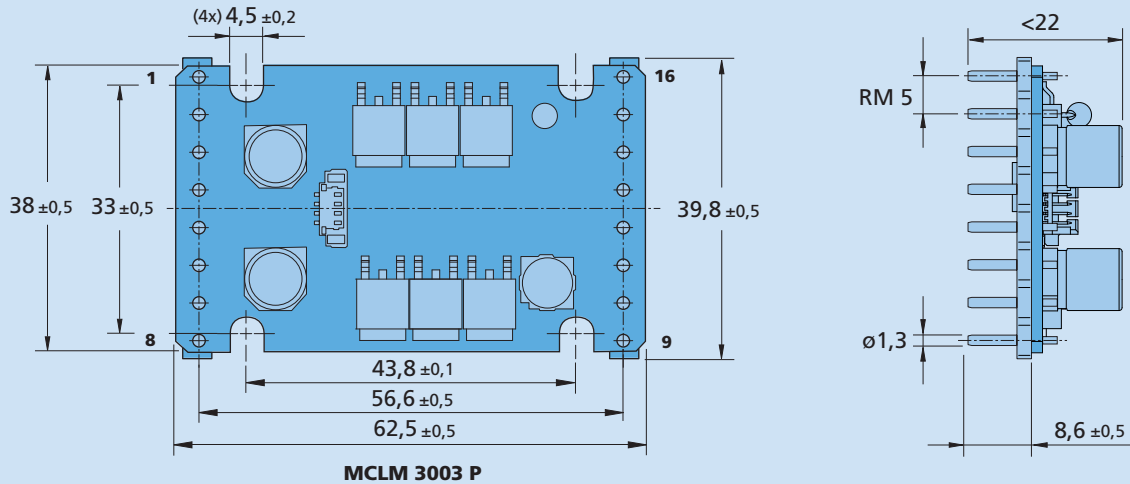

MCLM 3003 P

Options and connection information

Example product designation: **MCLM 3003 P RS 3085**

Option	Type	Description	Connection			
			No.	Function	No.	Function
3085	Supply	Separate power supply for motor and electronics	1	TxD / CAN_H	9	Sensor A
			2	RxD / CAN_L	10	Sensor B
			3	AGND	11	Sensor C
			4	Fault	12	U_{cc}
			5	AnIn	13	SGND
			6	U_b	14	Motor A
			7	GND	15	Motor B
			8	3. In	16	Motor C

Max. recommended current for continuous operation:
3A (at 22 °C ambient temperature)

CAUTION: Thermal shutdown is NOT guaranteed!

Note: For details on the connection assignment, see device manual MC.

Product combination

Linear DC-Servomotors	Cables / Accessories
LM 0830 ... 01 LM 1247 ... 11 LM 1483 ... 11 LM 2070 ... 11	To view our large range of accessory parts, please refer to the „Accessories“ chapter.

Motion Controllers

V2.5, 4-Quadrant PWM
with RS232 or CAN interface

MCLM 3006 S

Values at 22°C		MCLM 3006 S	
Power supply electronic	U_B/U_{EL}	12 ... 30	V DC
Power supply motor ¹⁾	$-U_B$	0 ... 30	V DC
PWM switching frequency	f_{PWM}	78,12	kHz
Efficiency electronic	η	95	%
Max. continuous output current	I_{cont}	6	A
Max. peak output current ²⁾	I_{max}	10	A
Standby current for electronic (at $U_B=24V$)	I_{el}	0,06	A
Operating temperature range		-40 ... +85	°C
Housing material		zinc, black coated	
Mass		160	g

¹⁾ Only available for option 3085 (separate power supply)

²⁾ S2 mode for max. 9s



Interfaces	MCLM 3006 S RS	MCLM 3006 S CO
Interface	RS232	CAN (CiA)
Protocol	FAULHABER - ASCII	CANopen

Basic features

- Operation of brushless linear DC-Servomotors
- Supported sensor systems: analog Hall sensors
- Positioning resolution when using analog Hall sensors as position encoder: 3000 increments per revolution
- Max. 3 digital inputs, max. 1 digital output, 1 analog input. Not all I/Os available depending on wiring
- Setpoint specification via fieldbus, quadrature signal, pulse and direction or analog inputs
- Optional stand-alone operation via application programs with the RS232 interface version

Range of functions

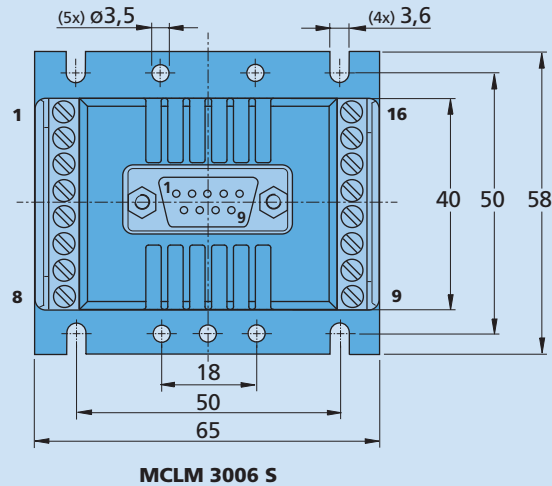
Operating modes (RS Versions)	Position, speed and torque control with setpoint specification via interface or analog. Position control with Gearing Mode or stepper motor operation. Operation as Servo Amplifier in voltage controller mode
Operating modes (CO Version)	Profile Position Mode (PP), Profile Velocity Mode (PV), Homing Mode.
Velocity range	2 mm/s ... 10 000 mm/s
Application programs	Available in versions with RS232 interface
Additional functions	Overload protection for electronics and motor, self-protection from overheating, over-voltage protection in generator mode.
Indicator	Trace as logger
Motor types	Brushless Linear DC-Servomotors with analog Hall sensors

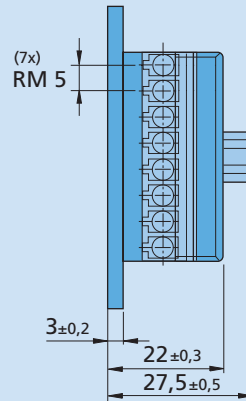
Dimensional drawing

 Scale reduced 

Options and connection information

 Example product designation: **MCLM 3006 S RS 3085**

Option	Type	Description	Connection	
3085	Supply	Separate power supply for motor and electronics	No. Function	No. Function
			1 TxD / CAN_H	9 Sensor A
			2 RxD / CAN_L	10 Sensor B
			3 AGND	11 Sensor C
			4 Fault	12 U _{cc}
			5 AnIn	13 SGND
			6 U _B	14 Motor A
			7 GND	15 Motor B
			8 3. In	16 Motor C
			D-SUB connector	
			RS-232	
			No. Function	No. Function
			2 RxD	2 CAN_L
			3 TxD	3 GND
			5 GND	5 -
			7 -	7 CAN_H
			Note: For details on the connection assignment, see device manual MC.	

Product combination

Linear DC-Servomotors	Cables / Accessories
LM 1247 ... 11 LM 1483 ... 11 LM 2070 ... 11	To view our large range of accessory parts, please refer to the „Accessories“ chapter.

Motion Controller

Technical Information



Features

FAULHABER Motion Controllers of generation V3.0 are highly dynamic, optimally tuned positioning controllers for use in combination with DC-motors as well as BL and LM DC-servomotors from FAULHABER's line of motors. The motor type can be configured during commissioning using the FAULHABER Motion Manager from version 6.0.

In addition to use as a servo drive with controlled position, the speed or current can also be controlled. The actual values for speed and position can be ascertained here using a number of supported sensor systems. Limit switches and reference switches can be directly connected.

The control setpoints can be preset via the communication interface, via the analogue input or a PWM input or can come from internally stored sequential programs.

Supported as communication interfaces are – depending on the device – USB and RS232, CANOpen and, optionally, EtherCAT. All functions of the drive are available here without limitation via all interfaces.

FAULHABER Motion Controllers of generation V3.0 are available in three sizes and three power classes:

- **MC 5004** – with a continuous current of up to 4 A, can be plugged directly into a motherboard and offers most I/Os
- **MC 5005** – with a continuous current of up to 5 A, is the ideal partner for most motors from the FAULHABER product portfolio
- **MC 5010** – with a continuous current of up to 10 A, is also suitable for applications with higher power requirements. Especially well suited for use in combination with the highly dynamic BL motors.

The possible applications are diverse: from laboratory automation to industrial equipment manufacturing, automation technology and robotics to aerospace.

The connection to the motors is established via pre-configured plugs or extension cables, which are available for all supported motors as options or as accessories.

Benefits

- One controller for all motor types and encoder types
- Very dynamic control
- Ideally matched to FAULHABER DC, BL and LM motors
- Various setpoint and actual value interfaces
- Stand-alone operation possible in all variants
- Connection via simple plug concept
- Fast feedback with status LEDs
- Commissioning with the free FAULHABER Motion Manager from version 6.0
- Extensive mounting accessories available

Product code



MC	Motion Controller
50	Max. supply voltage (50 V)
05	Max. continuous output current (5 A)
S	Housing with plug-in connections
RS	RS232 interface

MC_50_05_S_RS

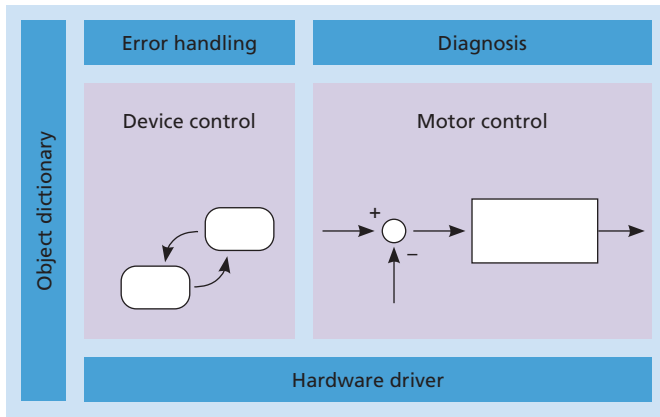

Operating modes

Motor control

Current, speed and position of the drive can be controlled via the controller cascade. By means of the optional pilot paths, even the fastest movements can be reliably controlled in a reproducible manner. Adjustable filters enable adaptation to a wide range of encoders and loads.

Motion profiles

Acceleration and brake ramp as well as the maximum speed can be preset in speed and positioning operation in the Profile Position Mode (PP) and Profile Velocity Mode (PV) operating modes.

Autonomous operation

Up to eight sequential programs written in BASIC can be stored and executed directly on the controller. One of these can be configured from the autostart application. Access protection can be activated.

Protection and diagnostic functions

FAULHABER Motion Controllers of generation V3.0 protect motors and electronics against overload by means of thermal models. The supply voltage is monitored and can also be used in regenerative operation. External devices are thereby protected against overvoltage during dynamic operation.

Profile Position Mode (PP) / Profile Velocity Mode (PV)

For applications in which only the target of the movement is specified for the controller. The acceleration and brake ramp as well as a possible maximum speed are taken into account via the integrated profile generator. Profile-based movements are, thus, suited for a combination with standard networks, such as RS232 or CANopen.

Cyclic Synchronous Position (CSP) / Cyclic Synchronous Velocity (CSV) / Cyclic Synchronous Torque (CST)

For applications in which a higher-level controller performs the path planning, even synchronised for multiple axes. The setpoints for position, speed and current are constantly updated. Typical update rates are in the range of a few milliseconds. Cyclic modes are, thus, primarily suited for combination with EtherCAT. CANopen can also be used.

Analogue Position Control (APC) / Analogue Velocity Control (AVC) / Analogue Torque Control (ATC)

For applications in which the setpoints of the control are specified as an analogue value or, e.g., via a directly connected reference encoder. These operating modes are therefore particularly well suited for stand-alone operation without higher-level master.

Voltage mode (VOLT)

In the voltage mode, only a current limiting controller is used. All control loops are closed by a higher-level system. The setpoint can be set via the communication system or via an analogue input.

Interfaces – discrete I/O

Three to eight digital inputs for connecting limit and reference switches or for connecting a reference encoder. The logic levels are switchable.

Two analogue inputs ($\pm 10V$) are available that can be freely used as setpoint or actual value.

Two to three digital outputs are available that can be freely used as error output, for direct actuation of a holding brake or as flexible diagnosis output.

Interfaces – position encoder

FAULHABER Motion Controllers of generation V3.0 support all sensor systems typically used on micro motors for position and speed as well as analogue or digital Hall signals, incremental encoders with and without Line Driver or protocol-based AES or SSI encoders.

Options

All controllers can optionally be equipped with an EtherCAT interface.

For highly dynamic applications, the use of a braking chopper can help to dissipate recovered energy.

Motion Controller

Technical Information

Networking

RS – systems with RS232 interface

Ideal for device construction and for all applications in which the Motion Controller is to be operated on an embedded controller. Using Net mode, it is also possible to operate multiple RS controllers on an RS232 interface. The transmission rate can lie between 9600 baud and 115 kbaud.

CO – CANopen acc. to CiA 402

The ideal variant for the operation of a FAULHABER Motion Controller on a PLC – directly via the CANopen interface or via a gateway on, e.g., Profibus/ProfiNET or on EtherCAT. Dynamic PDO mapping as well as node guarding or heartbeat are supported. Refresh rates for setpoint and actual values are typically from 10 ms here.

ET – EtherCAT

Motion Controller with direct EtherCAT interface. The controllers are addressed via CoE via the CiA 402 servo drive profile. Ideal in combination with a high-performance industrial controller that also performs path planning and interpolation of the movement for multiple axes. Refresh rates for setpoint and actual values from 0.5 ms are supported.

Interfaces – Bus Connection

Configuration

All Motion Controllers of generation V3.0 are equipped with a USB interface. This is intended primarily as a configuration interface. Via a USB to RS232 or USB to CAN converter, the drives can alternatively likewise be configured without restriction.

All described operating modes and functions are available independent of the used communication interface.

The interfaces can also be used in parallel, thereby allowing a drive to be integrated in an industrial interface via the CANopen or EtherCAT interface, while diagnostics are evaluated with the trace function via the USB interface.

General Information

System description

The products of the MC 5004, MC 5005 and MC 5010 series are variants of the FAULHABER Motion Controllers with and without housing and control either DC, LM or BL motors. The Motion Controllers are configured here via the FAULHABER Motion Manager.

The drives can be operated in the network via the CANopen or EtherCAT fieldbus interface. In smaller setups, networking can also be performed via the RS232 interface.

The Motion Controller operates in the network in principle as a slave; master functionality for actuating other axes is not provided.

After basic commissioning via the Motion Manager, the controllers can alternatively also be operated without communication interface.

The controllers of the MC 5004 series can be plugged into a motherboard via the 50-pin connector strip. For this purpose, FAULHABER offers a motherboard for connecting up to four controllers.

The controllers of the MC 5005 and MC 5010 series are secured to a flat base plate via the mounting holes. With optional accessories, mounting is also possible on a DIN rail.

Modifications and accessories

FAULHABER specialises in the adaptation of its standard products for customer-specific applications. The following standard options and accessory parts are available for FAULHABER Motion Controller MC V3.0:

- Connection cables for the supply and motor side
- Adapter sets for encoders
- Connector sets
- Motherboard MC 5004
- Programming adapter
- Starter kits
- Customized special configuration and firmware

Functional safety

STO – Safe Torque Off

The products of the MC 5004 P STO series have a function which safely shuts down the torque via a certified integrated safety circuit.

Disconnection through two redundant optocoupler inputs ensures operation up to safety integrity level SIL3 as defined by IEC 61800-5-2 and performance level PL e as defined by EN ISO 13849-1. Signalling and visualisation is via local LEDs as well as two separate outputs for status and error reporting.

The corresponding EC type examination is available for download at www.faulhaber.com.

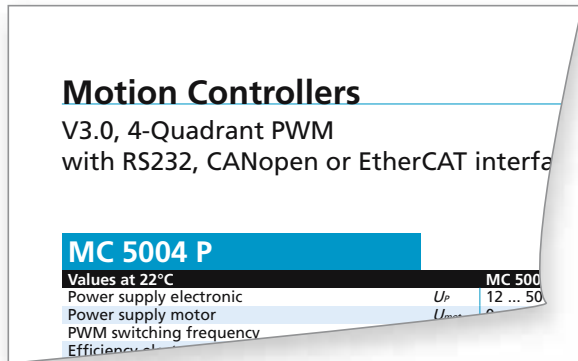

Explanatory Notes for Data Sheets

The following data sheet values of the Motion Controllers are measured or calculated at an ambient temperature of 22°C.

Motion Controllers of generation V3.0 generally feature – with the same ground connection – separate supply inputs for motor and electronics; if necessary, these inputs can also be used as a common supply.

Power supply for electronics U_p [V DC]

Describes the range of the permissible supply voltage for the control electronics.

Power supply for motor U_{mot} [V DC]

Describes the range of the permissible supply voltage for the motors connected to the MCs.

PWM switching frequency f_{PWM} [kHz]

Pulse width modulation describes the change of the electrical voltage between two values. Bell-type armature motors have a low electrical time constant. To keep the losses associated with PWM low, a high switching frequency is necessary. In generation V3.0, this value is fixed at 100 kHz. Through the type of pulse pattern generation (centre aligned), the switching frequency effective at the motor is twice as high.

Electronics efficiency η [%]

Ratio between consumed and delivered power of the control electronics.

Max. continuous output current I_{cont} [A]

Describes the current that the controller can continuously deliver to the connected motor at 22°C ambient temperature without additional cooling.

Max. peak output current I_{max} [A]

Describes the current that the controller can reach in S2 operation (cold start without additional cooling) at nominal conditions under constant load for the time specified in the data sheet without exceeding the thermal limit. Unless otherwise defined, the value that applies for the peak current is equal to three times the continuous current.

Standby current for the electronics I_{el} [A]

Describes the additional current consumption of the control electronics.

Operating temperature range [°C]

Shows the minimum and maximum operating temperature under nominal conditions.

Mass [g]

The typical mass of the standard controller may vary within the individual interface variants due to the different components.

Note

Speed range

The speed that can be reached in combination with a motor depends on the available voltage, the respective motor type and the maximum processing speed of the selected motion controller.

The maximum speed range refers to motors with one pole pair. On motors with a larger number of pole pairs, the speed range decreases accordingly.

$$\text{Maximum speed} = \frac{\text{Maximum speed with number of pole pairs 1}}{\text{Number of pole pairs of the connected motor}}$$

Manuals/Software

Device manuals for installation and commissioning, communication and function manuals as well as the “FAULHABER Motion Manager” software are available on request or on the Internet under www.faulhaber.com.

Motion Controller Software

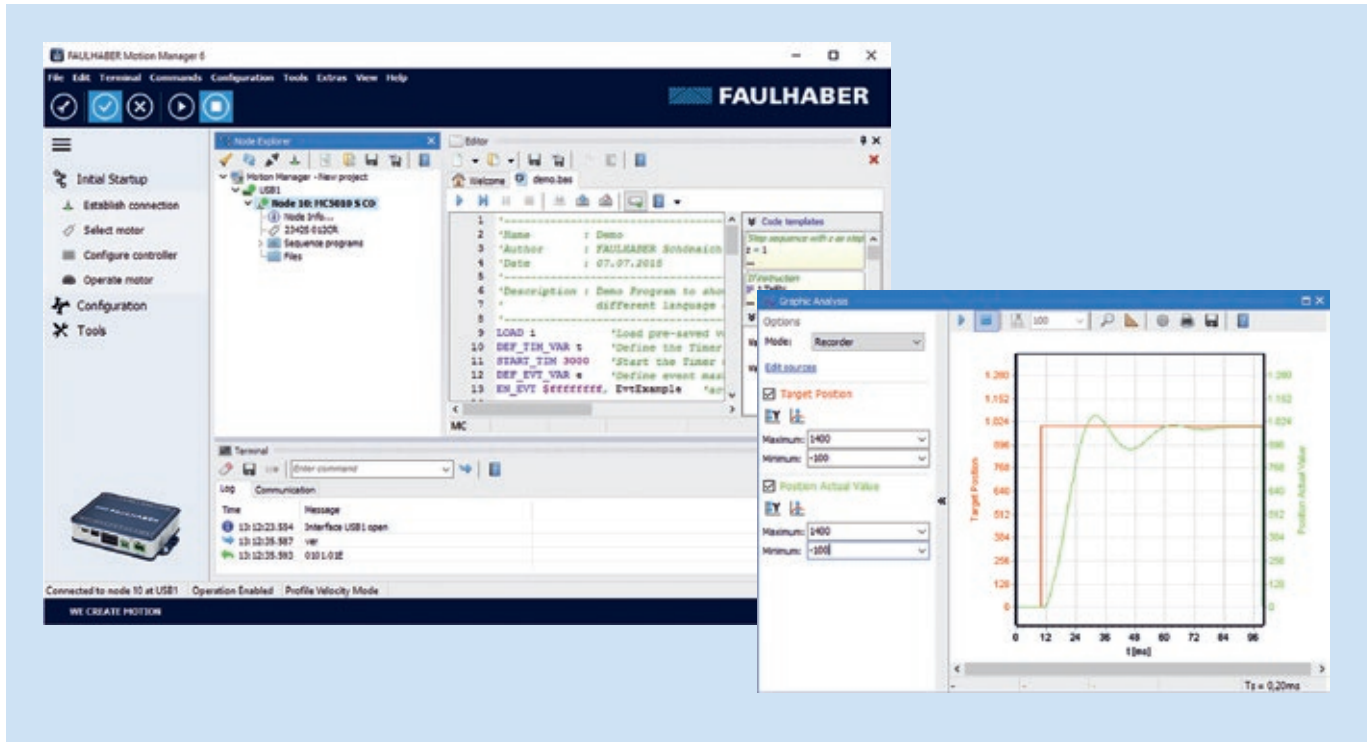

FAULHABER Motion Manager

The powerful 'FAULHABER Motion Manager' software is available for commissioning and configuring drive systems with motion and speed controllers.

Motion Manager generally supports interfaces RS232, USB and CANopen. Depending on the connected device, it may, however, be necessary to use an interface adapter, e.g., during the configuration of a Motion Control System via USB.

The graphical user interface makes uniform and intuitive procedures possible independent of the device family and interface used.

The software is characterised by the following features:

- Start-up support wizards
- Access to connected devices via Node-Explorer
- Configuration of drive functions and controller parameters using convenient, coordinated dialogues for the respective device family
- Context-sensitive online help
- Only for Motion Controllers:
 - Graphical analysis tools for drive behaviours and controller setting
 - Macro function for execution of program sequences
 - Development environment for sequential programmes and Visual Basic Script programmes

New features in Motion Manager 6:

- Completely revised user interface with window docking function
- Node-Explorer with integrated project management
- Support for the MC V3.0 family Motion Controller
 - Controller configuration with route identification
 - Expanded graphical analysis options
 - Further tools for operation and controller tuning

Supported Interfaces	Motion Controllers Motion Control Systems	Speed Controller Speed Control Systems
RS232	•	•
USB	•	•
CANopen	•	

“FAULHABER Motion Manager” for Microsoft Windows can be downloaded from www.faulhaber.com free of charge.

Commissioning and Configuration

FAULHABER Motion Manager can be used to easily access settings and parameters of the connected controller.

Wizards assist during the commissioning of a controller. Drive units detected on the selected interfaces are displayed in the device explorer.

The current interface and display settings can be saved in project files.

Sequential programs for saving and execution can be created, edited, transferred and executed on the devices. Possibilities for error detection and monitoring the program flow are also available.

The operation of a controller and the execution of motion tasks are performed via:

- Graphical operating elements
- Command entries
- Macro functions
- Programming of sequences via Visual Basic Script (VBScript)

Control parameters such as setpoints and actual values can be recorded in Logger or Recorder mode via a graphical analysis function. Additional tools are available for the creation and optimisation of control parameters.

Motion Controllers

V3.0, 4-Quadrant PWM
with RS232, CANopen or EtherCAT interface

MC 5004 P

Values at 22°C		MC 5004 P	
Power supply electronic	U_P	12 ... 50	V DC
Power supply motor	U_{mot}	0 ... 50	V DC
PWM switching frequency	f_{PWM}	100	kHz
Efficiency electronic	η	95	%
Max. continuous output current	I_{cont}	4	A
Max. peak output current ¹⁾	I_{max}	12	A
Standby current for electronic (at $U_P=24V$)	I_{el}	RS / CO: 0,06 ET: 0,07	A
Operating temperature range		-40 ... +85	°C
Mass		RS / CO: 22 ET: 47	g

¹⁾ S2 mode for max. 1s

Interfaces	MC 5004 P RS/CO	MC 5004 P ET
Configuration from Motion Manager 6.0	RS232 / USB	RS232 / USB
Fieldbus	RS232 / CANopen	EtherCAT

Basic features

- Control of brushless, DC- and linear motors
- Supported sensor systems: absolute encoders (AES or SSI), incremental encoders (optical or magnetic), Hall sensors (digital or analog), tachometers
- Positioning resolution when using analog Hall sensors as position encoder: 4096 increments per revolution
- 8 digital inputs, 3 digital outputs, 2 analog inputs, flexible configuration
- Setpoint specification via fieldbus, quadrature signal, pulse and direction or analog inputs
- Optional stand-alone operation via application programs in all interface versions

Range of functions

Operating modes	PP, PV, PT, CSP, CSV, CST and homing acc. to IEC 61800-7-201 or IEC 61800-7-301 as well as position-, speed- and torque control via analog setpoint or voltage controller
Speed range for brushless motors with number of pole pairs 1	0 min ⁻¹ ... 30 000 min ⁻¹ with sinusoidal commutation (optionally to 60 000 min ⁻¹ with block commutation)
Application programs	Max. 8 application programs (BASIC), one of which is an autostart function
Additional functions	Touch-probe input, connection of a second incremental encoder, control of a holding brake
Indicator	LEDs for displaying the operating state Trace as recorder (scope function) or logger
Motor types	DC, BL- and linear motors

Dimensional drawing

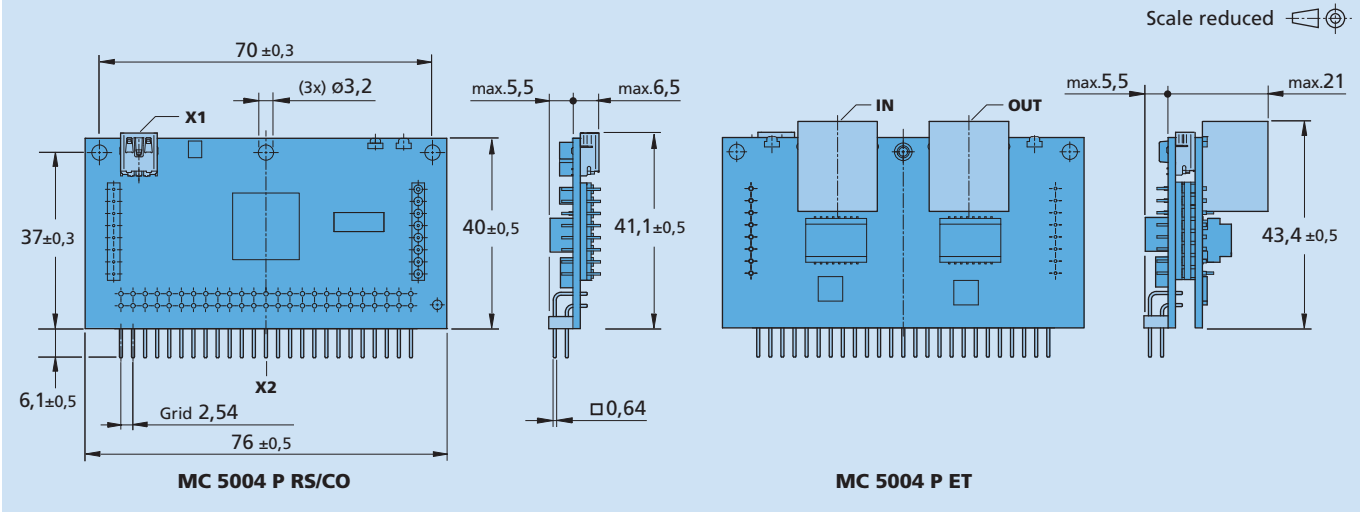

Options and connection information

Example product designation: **MC 5004 P ET FC**

Option	Type	Description	Connection	
			Name	Description
FC	EtherCAT IN/OUT 	Interface connector DIN, for use in combination with flat cables (see chapter "accessories")	X1	USB configuration interface USB
			X2	Pin Header Analog and digital input/output, motor and electronic, power supply, fieldbus, motor phases, sensors
5621	Multi-pin connector	Horizontal PCB assembly	IN	Fieldbus EtherCAT IN
			OUT	Fieldbus EtherCAT OUT
Note: For details on the connection assignment, see device manual for the MC 5004.				

Product combination

DC-Motors	Brushless DC-Motors	Linear DC-Servomotors	Cables / Accessories
1319 ... SR 1331 ... SR 1336 ... CXR 1516 ... SR 1524 ... SR 1717 ... SR 1724 ... SR 1727 ... CXR 1741 ... CXR 2224 ... SR 2232 ... SR 2237 ... CXR 2342 ... CR 2642 ... CR 2642 ... CXR 2657 ... CR 2657 ... CXR 2668 ... CR 3242 ... CR	3257 ... CR 3272 ... CR 1218 ... B 1226 ... B 1628 ... B 1645 ... BHS 1660 ... BHT 2036 ... B 2057 ... B 2214 ... BXT H 2232 ... BX4 2250 ... BX4 2250 ... BX4 S 2444 ... B 3056 ... B 3216 ... BXT H 3242 ... BX4 3268 ... BX4 4221 ... BXT H	LM 0830 ... 01 LM 1247 ... 11 LM 1483 ... 11 LM 2070 ... 11	<p>An extensive range of accessories is available for the products of the MC 5004 controller series.</p> <p>A motherboard is available that can be used to operate up to four controllers in multi-axis operation (slave).</p> <p>Furthermore, connection cables are available for controller and motor supply, sensors and interfaces as well as connector sets for the motor and supply side.</p> <p>To view our large range of accessory parts, please refer to the „Accessories“ chapter.</p>

Motion Controllers

V3.0, 4-Quadrant PWM
with RS232, CANopen or EtherCAT interface

MC 5004 P STO

Values at 22°C		MC 5004 P STO	
Power supply electronic	U_P	12 ... 50	V DC
Power supply motor ¹⁾	U_{mot}	0 ... 50	V DC
PWM switching frequency	f_{PWM}	100	kHz
Efficiency electronic	η	95	%
Max. continuous output current	I_{cont}	4	A
Max. peak output current ²⁾	I_{max}	12	A
Standby current for electronic (at $U_P=24V$)	I_{el}	RS / CO: 0,06 ET: 0,07	A
Permissible ambient temperature (operation)		-5 ... 40	°C
Permissible ambient temperature (storage)		-40 ... 85	°C
Mass		RS / CO: 28 ET: 52	g

¹⁾ Separate power supply not available in combination with Motherboard MB1 MC 5004 P STO

²⁾ S2 mode for max. 1s

Interfaces	MC 5004 P STO RS/CO	MC 5004 P STO ET
Configuration from Motion Manager 6.3	RS232 / USB	RS232 / USB
Fieldbus	RS232 / CANopen	EtherCAT

Basic features

- Control of brushless and linear motors
- Supported sensor systems: absolute encoders (AES or SSI), incremental encoders (optical or magnetic), Hall sensors (digital or analog), tachometers
- Position resolution when using analog Hall sensors as position encoders: 4096 increments per revolution
- 4 digital inputs, 2 digital outputs, 2 analog inputs, flexible configuration
- Setpoint specification via fieldbus, quadrature signal, pulse and direction or analog inputs
- Optional stand-alone operation via application programs in all interface versions
- Safe deactivation of torque via standardized integrated safe torque off circuit. Use up to security level SIL 3 according to IEC 61800-5-2 und PL e according to EN ISO 13849-1.
- Failure value $PFH^D = 4,57 \cdot 10^{-10}$, at a request rate of 1 per 8h. Activation via two redundant inputs, separate outputs for status and error indication.

Range of functions

Operating modes	PP, PV, PT, CSP, CSV, CST and homing acc. to IEC 61800-7-201 or IEC 61800-7-301 as well as position-, speed- and torque control via analog setpoint or voltage controller
Speed range for brushless motors with number of pole pairs 1	0 min ⁻¹ ... 30 000 min ⁻¹ with sinusoidal commutation (optionally to 60 000 min ⁻¹ with block commutation)
Application programs	Max. 8 application programs (BASIC), one of which is an autostart function
Additional functions	Touch-probe input, connection of a second incremental encoder, control of a holding brake
Indicator	LEDs for displaying the operating state Trace as recorder (scope function) or logger
Motor types	BL- and linear motors

Dimensional drawing

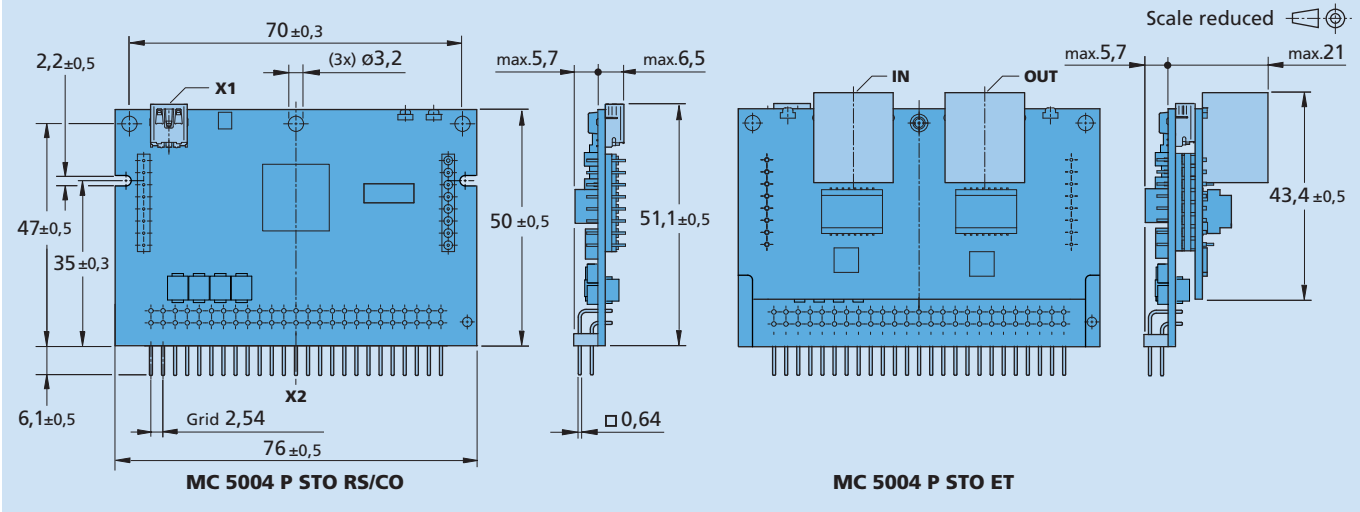

Options and connection information

Example product designation: **MC 5004 P STO ET FC**

Option	Type	Description	Connection	
FC	EtherCAT IN/OUT 	Interface connector DIN, for use in combination with flat cables (see chapter "accessories")	Name	Function
			X1	USB configuration interface
			X2	Pin Header
			IN	Fieldbus
			OUT	Fieldbus
				Description
				USB
				Analog and digital input/output, motor and electronic power supply, fieldbus, motor phases, sensors
				EtherCAT IN
				EtherCAT OUT
			Note: For details on the connection assignment, see device manual for the MC 5004 STO.	

Product combination

Brushless DC-Motors	Linear DC-Servomotors	Cables / Accessories
1218 ... B 1226 ... B 1628 ... B 1660 ... BHT 2036 ... B 2057 ... B 2232 ... BX4 2250 ... BX4 2250 ... BX4 S 2444 ... B 3056 ... B 3242 ... BX4 3268 ... BX4	LM 0830 ... 01 LM 1247 ... 11 LM 1483 ... 11 LM 2070 ... 11	<p>An extensive range of accessories is available for the products of the MC 5004 STO controller series.</p> <p>A motherboard is available that can be used to operate one controller in one-axis operation (slave).</p> <p>Furthermore, connection cables are available for controller and motor supply, sensors and interfaces as well as connector sets for the motor and supply side.</p> <p>To view our large range of accessory parts, please refer to the „Accessories“ chapter.</p>

Motion Controllers

V3.0, 4-Quadrant PWM
with RS232, CANopen or EtherCAT interface

MC 5005 S

Values at 22°C		MC 5005 S	
Power supply electronic	U_P	12 ... 50	V DC
Power supply motor	U_{mot}	0 ... 50	V DC
PWM switching frequency	f_{PWM}	100	kHz
Efficiency electronic	η	97	%
Max. continuous output current	I_{cont}	5	A
Max. peak output current ¹⁾	I_{max}	15	A
Standby current for electronic (at $U_P=24V$)	I_{el}	RS / CO: 0,06 ET: 0,07	A
Operating temperature range		-40 ... +85	°C
Housing material		aluminium, powder-coated	
Mass		RS / CO: 230 ET: 270	g

¹⁾ S2 mode for max. 60s

Interfaces	MC 5005 S RS	MC 5005 S CO	MC 5005 S ET
Configuration from Motion Manager 6.0	RS232 / USB	CANopen / USB	RS232 / USB
Fieldbus	RS232	CANopen	EtherCAT

Basic features

- Control of brushless, DC- and linear motors
- Supported sensor systems: absolute encoders (AES or SSI), incremental encoders (optical or magnetic), Hall sensors (digital or analog), tachometers
- Positioning resolution when using analog Hall sensors as position encoder: 4096 increments per revolution
- 3 digital inputs, 2 digital outputs, 2 analog inputs, flexible configuration
- Setpoint specification via fieldbus, quadrature signal, pulse and direction or analog inputs
- Optional stand-alone operation via application programs in all interface versions

Range of functions

Operating modes	PP, PV, PT, CSP, CSV, CST and homing acc. to IEC 61800-7-201 or IEC 61800-7-301 as well as position-, speed- and torque control via analog setpoint or voltage controller
Speed range for brushless motors with number of pole pairs 1	0 min ⁻¹ ... 30 000 min ⁻¹ with sinusoidal commutation (optionally to 60 000 min ⁻¹ with block commutation)
Application programs	Max. 8 application programs (BASIC), one of which is an autostart function
Additional functions	Touch-probe input, connection of a second incremental encoder, control of a holding brake
Indicator	LEDs for displaying the operating state Trace as recorder (scope function) or logger
Motor types	DC, BL- and linear motors

Dimensional drawing

Scale reduced

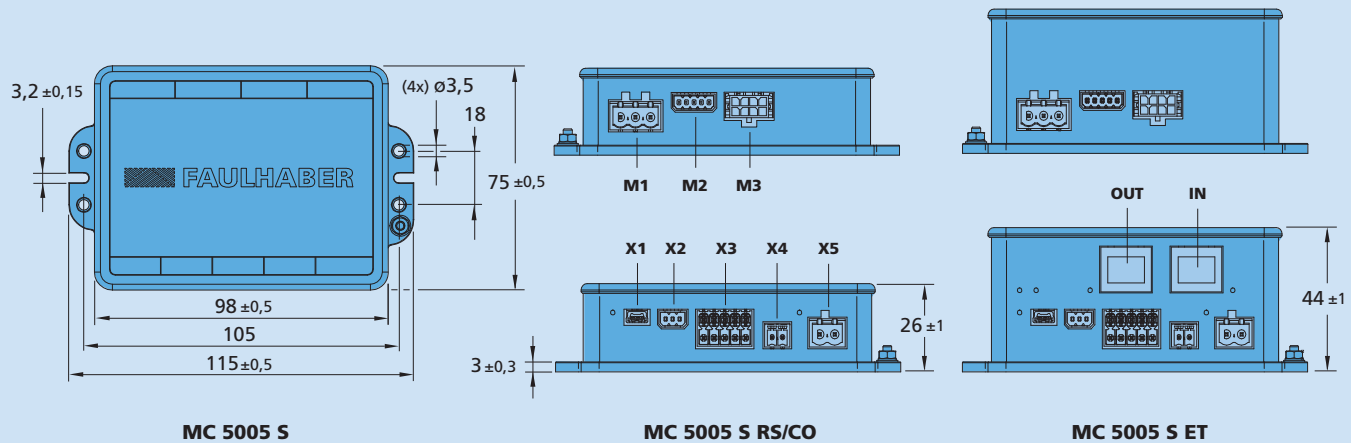
Options and connection information

 Example product designation: **MC 5005 S RS**

Option	Type	Description	Connection			
			Name	Function	Input/Output	Description
6419	Encoder combination	Integrated terminating resistor for combination with absolute encoder AES-4096L	X1	Configuration interface		USB
			X2	Fieldbus		RS: RS232 CO: CANOpen
			X3	Input/Output	DigIn1, DigIn2, DigIn3 DigOut1, DigOut2 AnIn1, AnIn2 U _{out} / GND	TTL or PLC level max. 0,7A cont. current ± 10V against AGND 5V
			X4	Electronic power supply		
			X5	Motor power supply		
			M1	Motor phases	A, B, C	
			M2	Hall sensors	A, B, C U _{out} / GND	digital or analog 5V
			M3	Encoder	A, \bar{A} , B, \bar{B} , I, \bar{I} EN, \bar{EN} , CLOCK, \bar{CLOCK} , DATA, \bar{DATA} U _{out} / GND	max. 5MHz AES or SSI 5V
			IN	Fieldbus		EtherCAT IN
			OUT	Fieldbus		EtherCAT OUT
			Note: For details on the connection assignment, see device manual for the MC 5005.			

Product combination

DC-Motors	Brushless DC-Motors	Linear DC-Servomotors	Cables / Accessories
2237 ... CXR 2342 ... CR 2642 ... CR 2642 ... CXR 2657 ... CR 2657 ... CXR 2668 ... CR 3242 ... CR 3257 ... CR 3272 ... CR	1645 ... BHS 1660 ... BHT 2036 ... B 2057 ... B 2214 ... BXT H 2232 ... BX4 2250 ... BX4 2250 ... BX4 S 2444 ... B 3056 ... B 3216 ... BXT H 3242 ... BX4 3268 ... BX4 3564 ... B 4221 ... BXT H	LM 1247 ... 11 LM 1483 ... 11 LM 2070 ... 11	<p>An extensive range of accessories is available for the products of the MC 5010 and MC 5005 controller series.</p> <p>Included here are connection cables for controller and motor supply, sensors and interfaces, connector sets for motor- and supply side as well as mechanical components for optional top hat rail mounting.</p> <p>To view our large range of accessory parts, please refer to the „Accessories“ chapter.</p>

Motion Controllers

V3.0, 4-Quadrant PWM
with RS232, CANopen or EtherCAT interface

MC 5010 S

Values at 22°C		MC 5010 S	
Power supply electronic	U_P	12 ... 50	V DC
Power supply motor	U_{mot}	0 ... 50	V DC
PWM switching frequency	f_{PWM}	100	kHz
Efficiency electronic	η	97	%
Max. continuous output current	I_{cont}	10	A
Max. peak output current ¹⁾	I_{max}	30	A
Standby current for electronic (at $U_P=24V$)	I_{el}	RS / CO: 0,06 ET: 0,07	A
Operating temperature range		-40 ... +85	°C
Housing material		aluminium, powder-coated	
Mass		RS / CO: 230 ET: 270	g

¹⁾ S2 mode for max. 3s

Interfaces	MC 5010 S RS	MC 5010 S CO	MC 5010 S ET
Configuration from Motion Manager 6.0	RS232 / USB	CANopen / USB	RS232 / USB
Fieldbus	RS232	CANopen	EtherCAT

Basic features

- Control of brushless, DC- and linear motors
- Supported sensor systems: absolute encoders (AES or SSI), incremental encoders (optical or magnetic), Hall sensors (digital or analog), tachometers
- Positioning resolution when using analog Hall sensors as position encoder: 4096 increments per revolution
- 3 digital inputs, 2 digital outputs, 2 analog inputs, flexible configuration
- Setpoint specification via fieldbus, quadrature signal, pulse and direction or analog inputs
- Optional stand-alone operation via application programs in all interface versions

Range of functions

Operating modes	PP, PV, PT, CSP, CSV, CST and homing acc. to IEC 61800-7-201 or IEC 61800-7-301 as well as position-, speed- and torque control via analog setpoint or voltage controller
Speed range for brushless motors with number of pole pairs 1	0 min ⁻¹ ... 30 000 min ⁻¹ with sinusoidal commutation
Application programs	Max. 8 application programs (BASIC), one of which is an autostart function
Additional functions	Touch-probe input, connection of a second incremental encoder, control of a holding brake
Indicator	LEDs for displaying the operating state Trace as recorder (scope function) or logger
Motor types	DC, BL- and linear motors

Dimensional drawing

Scale reduced

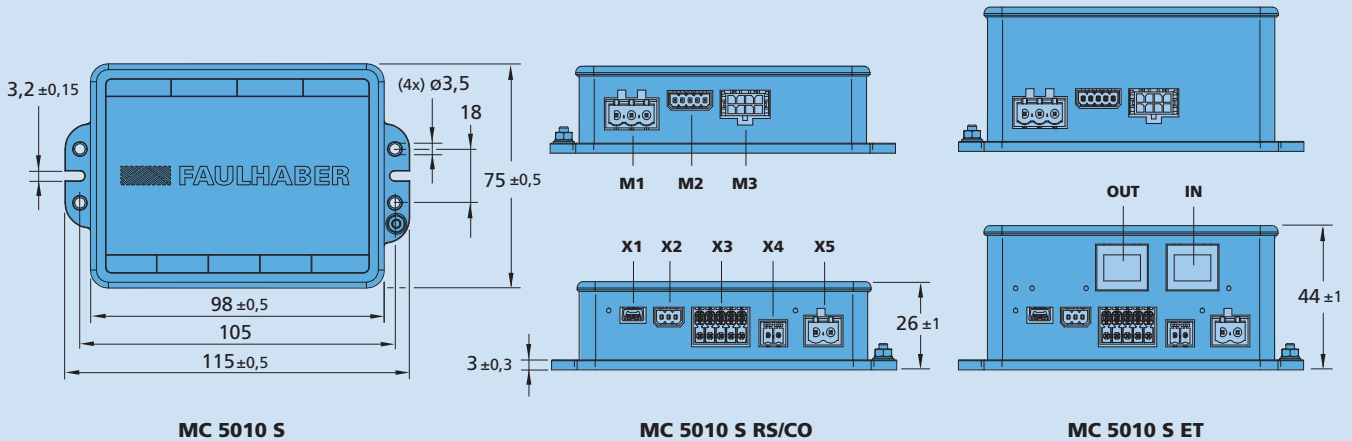
Options and connection information

 Example product designation: **MC 5010 S RS**

Option	Type	Description	Connection			
			Name	Function	Input/Output	Description
6419	Encoder combination	Integrated terminating resistor for combination with absolute encoder AES-4096L	X1	Configuration interface		USB
			X2	Fieldbus		RS: RS232 CO: CANOpen
			X3	Input/Output	DigIn1, DigIn2, DigIn3 DigOut1, DigOut2 AnIn1, AnIn2 U _{out} / GND	TTL or PLC level max. 0,7A cont. current ± 10V against AGND 5V
			X4	Electronic power supply		
			X5	Motor power supply		
			M1	Motor phases	A, B, C	
			M2	Hall sensors	A, B, C U _{out} / GND	digital or analog 5V
			M3	Encoder	A, \bar{A} , B, \bar{B} , I, \bar{I} EN, $\bar{E}N$, CLOCK, $\bar{C}LOCK$, DATA, $\bar{D}ATA$ U _{out} / GND	max. 5MHz AES or SSI 5V
			IN	Fieldbus		EtherCAT IN
			OUT	Fieldbus		EtherCAT OUT
			Note: For details on the connection assignment, see device manual for the MC 5010.			

Product combination

DC-Motors	Brushless DC-Motors	Cables / Accessories
3242 ... CR 3257 ... CR 3272 ... CR 3863 ... CR 3890 ... CR	2264 ... BP4 3242 ... BX4 3268 ... BX4 3274 ... BP4 3564 ... B 4490 ... B 4490 ... BS	<p>An extensive range of accessories is available for the products of the MC 5010 and MC 5005 controller series.</p> <p>Included here are connection cables for controller and motor supply, sensors and interfaces, connector sets for motor- and supply side as well as mechanical components for optional top hat rail mounting.</p> <p>To view our large range of accessory parts, please refer to the „Accessories“ chapter.</p>

Notes



Stepper motors Motion Controller

Technical Information

Connection variants

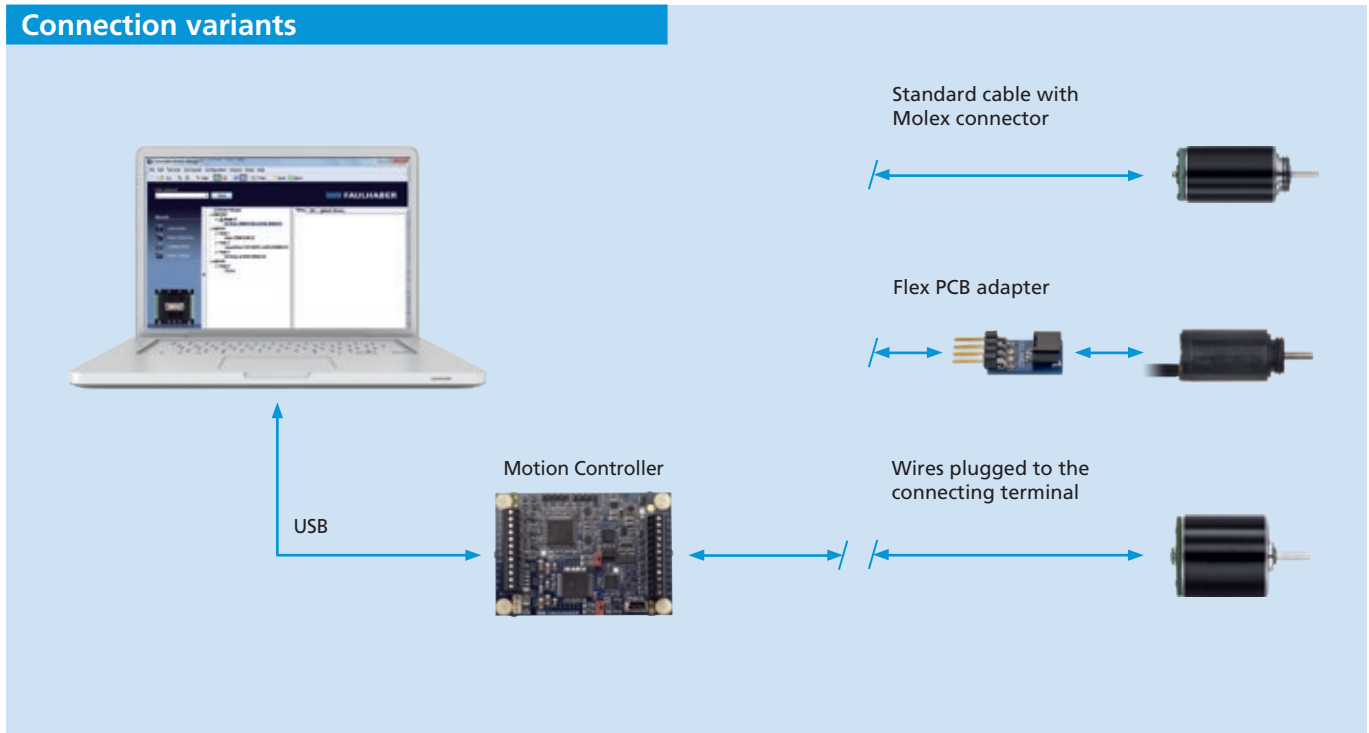

Features

FAULHABER stepper motor motion controllers are highly dynamic positioning systems tailored specifically to the requirements of micro stepper motor operations.

In addition to be able to control the whole FAULHABER stepper motor range, the controllers are capable of managing three axes positioning (requires 2 additional boards). Reference search and encoder management functions are part of the numerous features offered by the controllers.

A complete IDE is included, allowing the user to benefit from the full range of functionalities, through a very comprehensive and user friendly interface.

The integrated systems require less space, as well as making installation much simpler thanks to their reduced wiring.

Benefits

- Fully programmable via software (Graphic User Interface)
- USB interface
- 9V...36VDC / 50mA to 1.1A
- Microstepping up to 1/256
- 4 GPI and 7 GPO
- Can be used as step/direction driver only
- Reference input (for homing functions)
- Compatible with LabView
- Board size: 68mm x 47.5mm

Product Code



MC	Motion Controller
ST	Stepper Motor
36	Max. supply voltage (36V)
01	Max. continuous output current (1A)

MC ST 36 01

Stepper motors Motion Controller

Technical Information

Main characteristics

Motion controller

- Motion profile calculation in real-time
- On the fly alteration of motor parameters (e.g. position, velocity, acceleration)
- High performance microcontroller for overall system control and serial communication protocol handling

Bipolar stepper motor driver

- Up to 256 microsteps per full step
- High-efficient operation, low power dissipation
- Dynamic current control
- Integrated protection

Software

- TMCL™: standalone operation or remote controlled operation
- PC-based application development software TMCL™ – IDE available for free.

Operating modes

Standalone

A program is stored in the controller board memory, and starts when the system is powered ON. The software is able to react with external stimulus, such as digital I/Os, encoders, sensors, etc. Standard processor instructions list as well as complete list of motor positioning control functions are available for the programmer.

Direct mode

Using IDE "direct mode" functions, the user is able to send instructions to the board one by one, through USB link. Status information and position/speed values can be read in real time by the user, thanks to dedicated GUI.

Remote software

The controller can be remotely controlled through USB link, by any user developed software. Labview and C++ libraries are available to be used with the controller.

Special functions

Speed profiles

Motors movements are realized using user definable speed profiles. The latter can be setup using a complete parameter calculator interface, helping the user to find the most suited speed values.

StallGuard™

Stall detection feature allows the controller to react in case of step losses, and can also be used to detect any motor hard stop reach.

CoolStep™

Current flowing to the motor is automatically adapted in case of load variation. This feature allows a reduced power consumption of the whole system.

Homing

Reference search process can be done automatically by the controller on startup. The user can setup the way to perform the operation (direction, switches number, origin location, etc.).

Interfaces

- USB device interface (on-board mini-USB connector)
- 6x open drain outputs (24V compatible)
- REF_L / REF_R / HOME switch inputs (24V compatible with programmable pull-ups)
- 1x S/D input for the on-board driver (on-board motion controller can be deactivated)
- 2x step / direction output for two separate external drivers (in addition to the on-board)
- 1x encoder input for incremental a/b/n encoder
- 3x general purpose digital inputs (24V compatible)
- 1x analog input (0 .. 10V)

Please note: Not all functions are available at the same time as connector pins are shared.

Notes

Device manuals for installation and start up, communication and function manuals, and the "TMCL™ – IDE" software are available on request and on the Internet at www.faulhaber.com.

Stepper motors Motion Controller Software

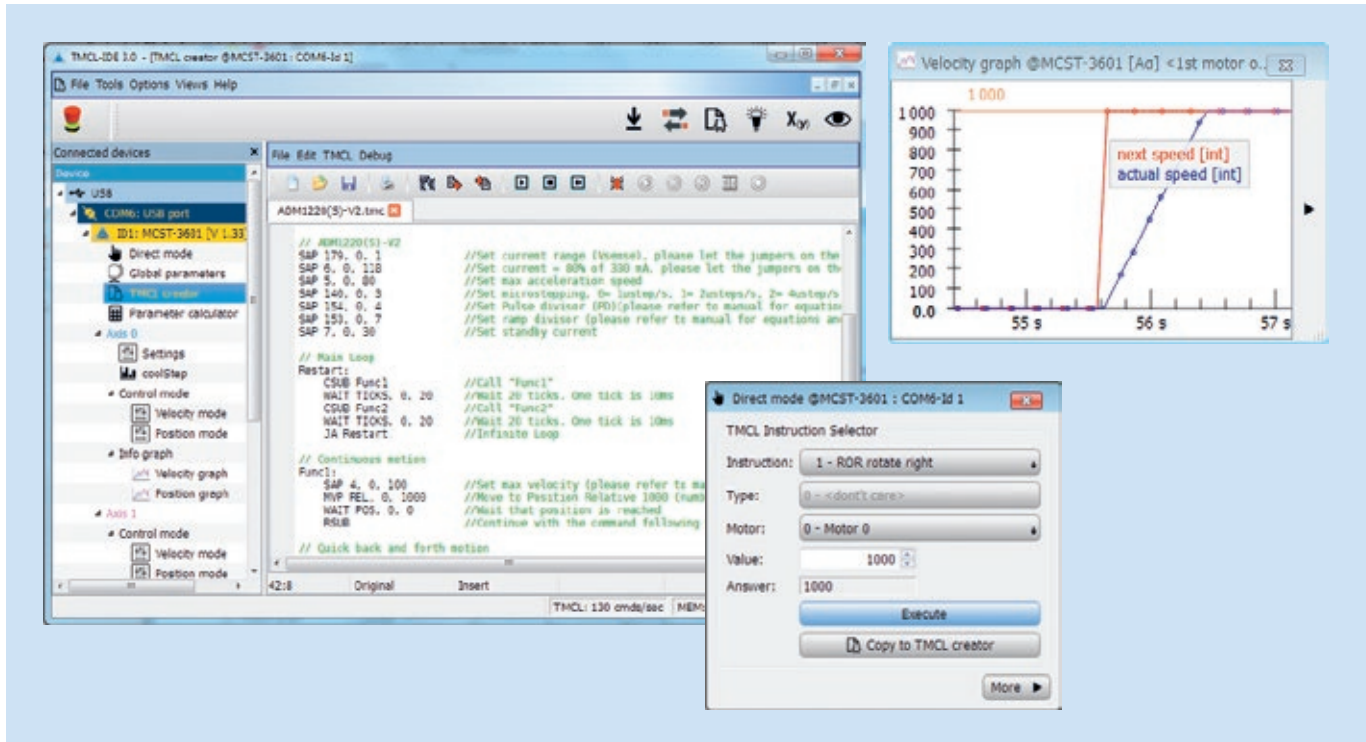

TMCL™ – IDE

The high-performance software solution “TMCL™ – IDE” enables users to control and configure the stepper motors controller, through USB interface.

“TMCL™ – IDE” software and lots of program examples can be downloaded free of charge from www.faulhaber.com.

Startup and configuration

Drivers and libraries are automatically installed together with the TMCL™-IDE software. Connected controller device is immediately detected and recognized by the software. The graphical user interface can be used to read out, change and reload configurations. Individual commands or complete parameter sets and program sequences can be entered and transferred to controller.

Operation of drives is also supported by several wizards, helping user to easily setup all the parameters.

Quickstart, hardware and firmware complete user manuals are also available for the user and can be downloaded free of charge from www.faulhaber.com. Please refer to the Quickstart manual before first use.

Motion Controller

1-Axis controller with microstepping,
USB interface and GPIO

For combination with:
Stepper motors

Series MCST 3601

		MCST 3601	
Power supply	U_B	9 ... 36	V DC
PWM switching frequency	f_{PWM}	16 000	kHz
Max. continuous output current range ¹⁾	I_{dauer}	0 ... 1,1	A
Max. peak output current	I_{max}	1,6	A
Max. current resolution		5	mA
Microstepping		up to 256 ²⁾	
Scanning rate (in full step mode)	N	30	μ s
Inputs:			
– Digital, 24 VDC		3	
– Analog, 10 VDC		1	
Outputs:			
– Open drain, 24 VDC		6	
– +5 VDC, 100 mA		1	
Operating temperature range		– 30 ... + 70	°C
Mass		22	g

¹⁾ at 22°C ambient temperature

²⁾ μ step/full step

Connection information

Connections 1-6 :		digital input	
REF_L / DIR_IN	left stop switch input	programmable pull-up to +5V or direction input in S/D ⁴⁾ operation mode	
REF_R / EN_IN	right stop switch input	programmable pull-up to +5V or enable input in S/D ⁴⁾ operation mode	
HOME / STEP_IN	home switch input	programmable pull-up to +5V or step input in S/D ⁴⁾ operation mode	
ENC_A / IN1	incremental encoder	channel A input or digital input 1	
ENC_B / IN2	incremental encoder	channel B input or digital input 2	
ENC_I / IN3	incremental encoder	index / null channel I input or digital input 3	
Connection 7 :		+5V output	
Current range		0 ... 100	mA
Connection 8, 13³⁾, 24 :		GND	
Signal ground			
Connection 9-12 :		motor A+, A-, B+, B-	
Output voltage		= U_B	VDC
Coil current range		0 ... 1,1	A
(depends on programming and jumper settings)		0 ... 1,6 (Peak)	A
Connection 14³⁾ :		U_B	
Supply voltage range		9 ... 36	VDC
Connection 15-16 :		reserved	
Max speed rate transfer		1	Mbits/s
Max number of nodes		110	
Value of the termination resistors (2x)		120	Ohm
Connections 17-22 :		digital output	
Voltage range open drain outputs		= U_B	VDC
Current range open drain outputs		0 ... 100	mA
Connection 23 :		analog input	
Voltage range		0 ... 10	VDC

³⁾ Crossing the connections 13 and 14 may irreversibly damage the controller.

⁴⁾ S/D = step and direction (direct drive) mode.

Features

The MCST3601 is a stepper motor controller that is mostly intended to be used as an evaluation board. It has the capability to drive the full range of stepper motors thanks to a selected current range.

This range must be selected manually through jumpers and programmed with the TMCL-IDE software.

The USB communication makes it fully programmable and the many inputs and outputs enable an external interaction.

Full step or microstepping up to 256 can be managed by programming.

Moreover, the MCST3601 comprises screw terminals for quick setup and a Molex connector compatible with the standard cables solutions offered on stepper motors.

When controlling several axis, one driver per axis is required but there is a possibility to coordinate the different axis by using the MCST3601 as „Master“ and up to two other boards as „Slaves“. The slave boards are then addressed as step and direction drivers by the master board. MCST3601 can also be converted in one of those step and direction driver.

Finally, the MCST3601 has the capability to read and treat an external input signal that may be sent by a sensor or an encoder. This is very useful in the case where a homing function must be made before starting the movement, in other words, when the motor is looking for a reference position before starting. Note that this function is not acting like a closed loop regulator.

Accessories

The MCST3601 is delivered with one USB cable and four spacer bolt.

Dimensional drawing and connection information MCST 3601

 Scale reduced

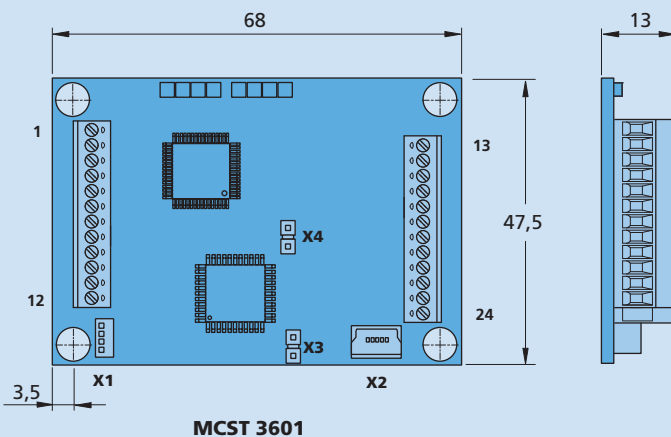

Motor connection

No.	Function
1	REF_L / DIR_IN
2	REF_R / EN_IN
3	HOME / STEP_IN
4	ENC_A / IN1
5	ENC_B / IN2
6	ENC_I / IN3
7	+5Vout / 100mA
8	GND
9	Motor A+
10	Motor A-
11	Motor B+
12	Motor B-

X1 Motor connector

Connector housing:
Molex 51021-0400
Contacts: Molex 50079-8000
Wire: AWG 26-28

Supply connection

No.	Function
13	GND
14	U _B
15	reserved
16	reserved
17	OUT0
18	OUT1
19	OUT2
20	OUT3
21	OUT4
22	OUT5
23	IN0
24	GND

X2 USB 2.0 (12Mbit/s)

Any standard mini-USB plug compatible with Molex 500075-1517

X3, X4 Jumpers for current settings