

» CASM-32 | cont. 327 N, peak 700 N

- » Electric cylinder with strokes up to 400 mm
- » With brushless DC servomotors
- » Lead and ball screw version
- » Twist protected thrust rod
- » In-line and parallel motor version
- » Alternative for pneumatic cylinder
- » Compact and space saving
- » Easy configuration of max. 14 positions (PI motor)
- » Several BUS interfaces available
- » PLG 42 on request

- » Elektrischer Hubzylinder mit Hube von bis zu 400 mm
- » Mit bürstenlosem DC-Servomotoren
- » Gleitspindel und Kugelrollspindel Versionen
- » Verdreh gesicherte Schubstange
- » In-Line und parallele Motorausführung
- » Alternative zu Pneumatik Zylinder
- » Kompakt und platzsparend
- » Einfache Konfiguration von bis zu 14 Positionen (PI Motor)
- » Verschiedene BUS-Schnittstellen verfügbar
- » Auf Anfrage mit PLG 42

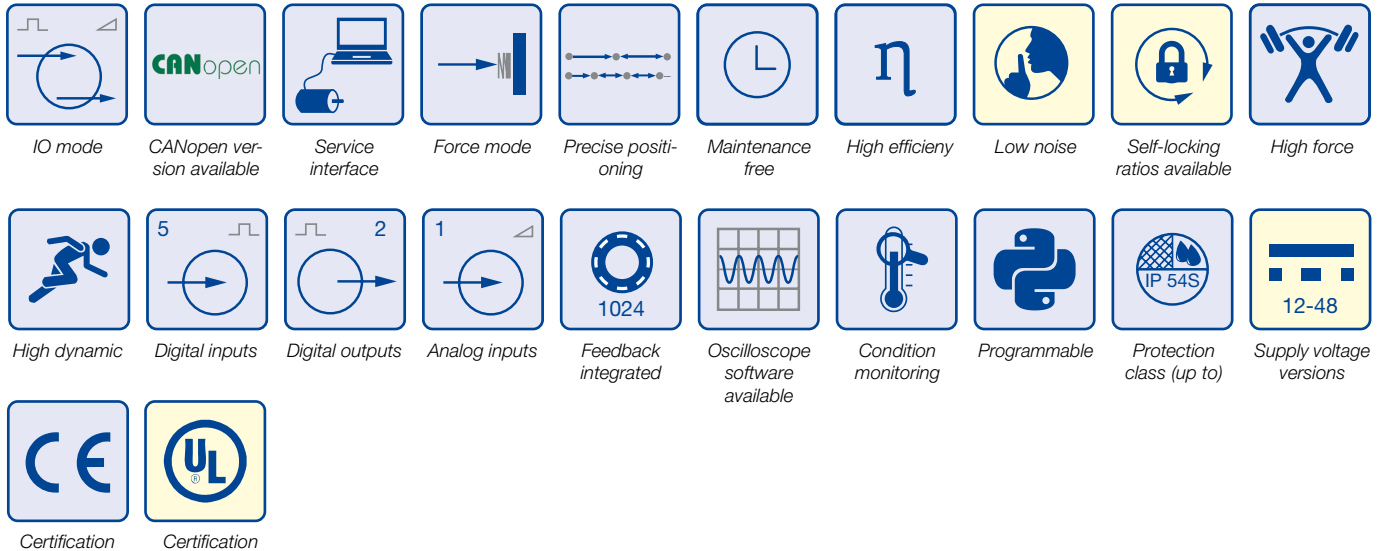
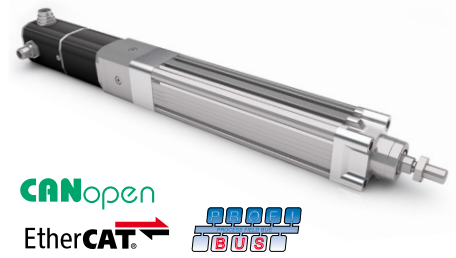

Data/ Technische Daten		CASM-32		
Motor type/ Motortyp		BG 45x30		
Nominal voltage/ Nennspannung	VDC	24		
Nominal current/ Nennstrom	A	4.9		
Peak current (2 sec.)/ Spitzenstrom (2 sec.)	A	15		
Spindle version/ Spindelversion	-	LS	BS	BN
Spindle pitch/ Spindelsteigung	mm	1.5	3	10
Constant force/ Dauerkraft	N	300	327	131
Peak force/ Spitzenkraft	N	300	700	462
Max. traverse speed/ Max. Verfahrensgeschwindigkeit	mm/s	60	150	500
Max. acceleration/ Max. Beschleunigung	m/s ²	1	6	
Repeatability/ Wiederholgenauigkeit	mm	+/- 0.07	+/- 0.01	
Lifetime L ₁₀ / Lebensdauer L ₁₀	km	70	Siehe Diagramm	
Stroke length/ Hublängen	mm	50 / 100 / 150 / 200 / 300 / 400		

LS: Lead screw/ Gleitspindel *Not applicable for motions on mechanical stop./ Nicht geeignet für Bewegungen auf mechanischem Anschlag.*
 BS / BN: Ball screw/ Kugelrollspindel Preference/ Vorzugsreihe On request/ auf Anfrage

Dimensions/ Maßzeichnung

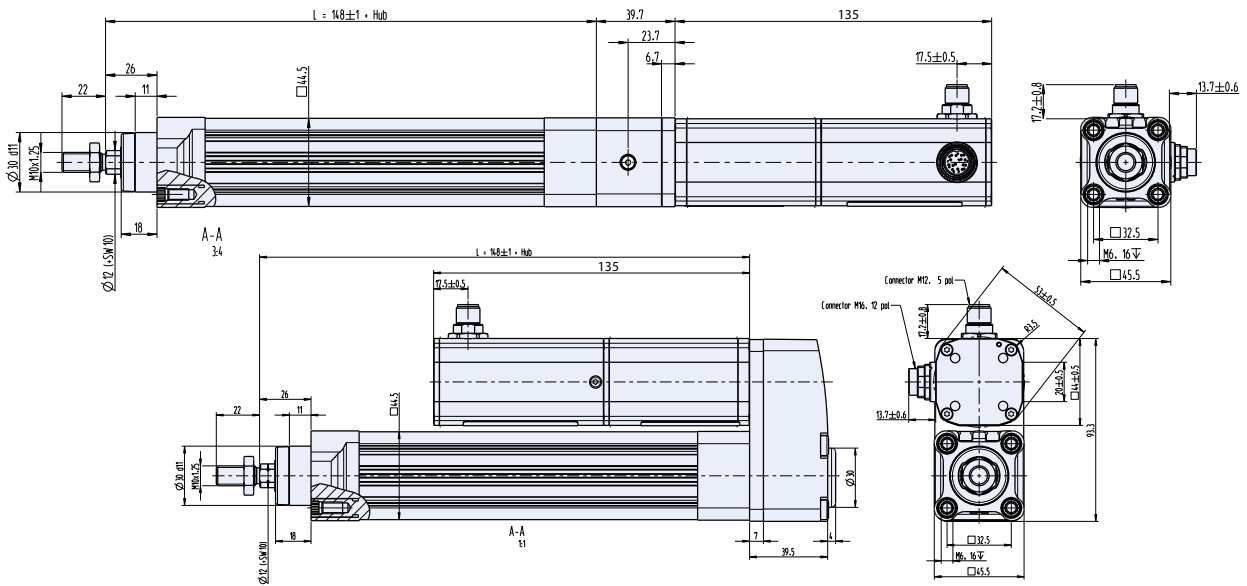

Characteristic diagram/ Belastungskennlinien @25°C

Load/ linear speed diagram

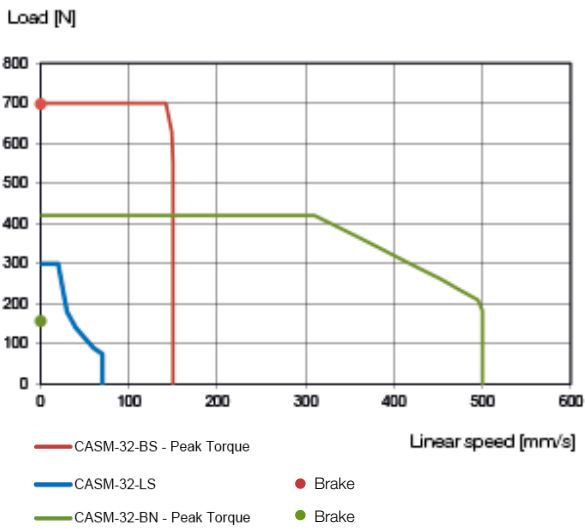

Load = force acting on the actuator
(gravity force + acceleration force + constant force)

Shear load [N]

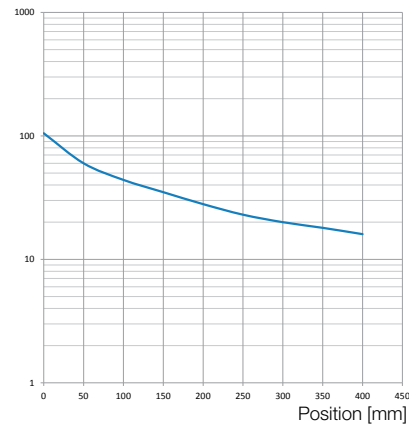

Shear load diagram
The shear load acts at right angles to the movement direction.
Nominal load [N]

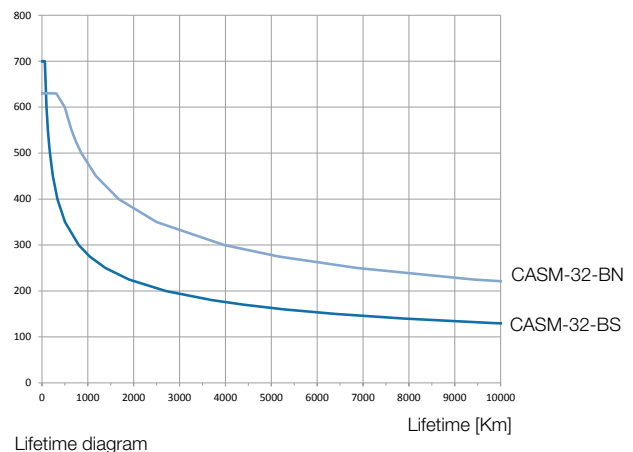

- » Electric cylinder with strokes up to 600 mm
- » With brushless DC servomotors
- » Lead and ball screw version
- » Twist protected thrust rod
- » In-line and parallel motor version
- » Alternative for pneumatic cylinder
- » Compact and space saving
- » Easy configuration of max. 14 positions (PI motor)
- » Several BUS interfaces available
- » PLG 52 on request

- » Elektrischer Hubzylinder mit Hube von bis zu 600 mm
- » Mit bürstenlosem DC-Servomotoren
- » Gleitspindel und Kugelrollspindel Versionen
- » Verdreh gesicherte Schubstange
- » In-Line und parallele Motorausführung
- » Alternative zu Pneumatik Zylinder
- » Kompakt und platzsparend
- » Einfache Konfiguration von bis zu 14 Positionen (PI Motor)
- » Verschiedene BUS-Schnittstellen verfügbar
- » Auf Anfrage mit PLG 52

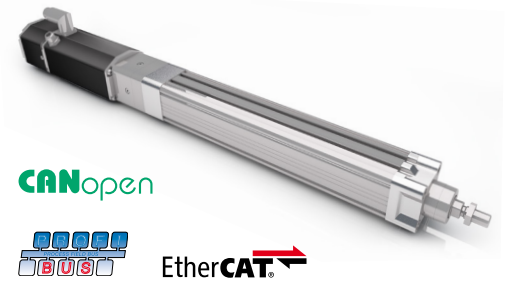

IO mode	CANopen version available	Service interface	Force mode	Precise positioning	Maintenance free	High efficiency	Low noise	Self-locking ratios available	High force
High dynamic	Digital inputs	Digital outputs	Analog inputs	Feedback integrated	Oscilloscope software available	Condition monitoring	Programmable	Protection class (up to)	Supply voltage versions
Certification	Certification								

Data/ Technische Daten		CASM-40					
		BG 65x50			BG 75x75		
Motor type/ Motortyp		BG 65x50			BG 75x75		
Nominal voltage/ Nennspannung	VDC	40-48			40-48		
Nominal current/ Nennstrom	A	7			12.7		
Peak current (2 sec.)/ Spitzenstrom (2 sec.)	A	20			50		
Spindle version/ Spindelversion	-	LS	BS	BN	LS	BS	BN
Spindle pitch/ Spindelsteigung	mm	2.5	5	12.7	2.5	5	12.7
Constant force/ Dauerkraft	N	465	440	198	600	1020	459
Peak force/ Spitzenkraft	N	600	1170	526	600	2375	1484
Max. traverse speed/ Max. Verfahrgeschwindigkeit	mm/s	70	300	825	70	300	825
Max. acceleration/ Max. Beschleunigung	m/s ²	1	6		1	6	
Repeatability/ Wiederholgenauigkeit	mm	+/- 0.07	+/- 0.01		+/- 0.07	+/- 0.01	
Lifetime L ₁₀ / Lebensdauer L ₁₀	km	100	Siehe Diagramm		100	Siehe Diagramm	
Stroke length/ Hublängen	mm	100 / 200 / 300 / 400 / 500 / 600					

LS: Lead screw/ Gleitspindel *Not applicable for motions on mechanical stop./ Nicht geeignet für Bewegungen auf mechanischem Anschlag.*
 BS / BN: Ball screw/ Kugelrollspindel Preference/ Vorzugsreihe On request/ auf Anfrage

Dimensions/ Maßzeichnung

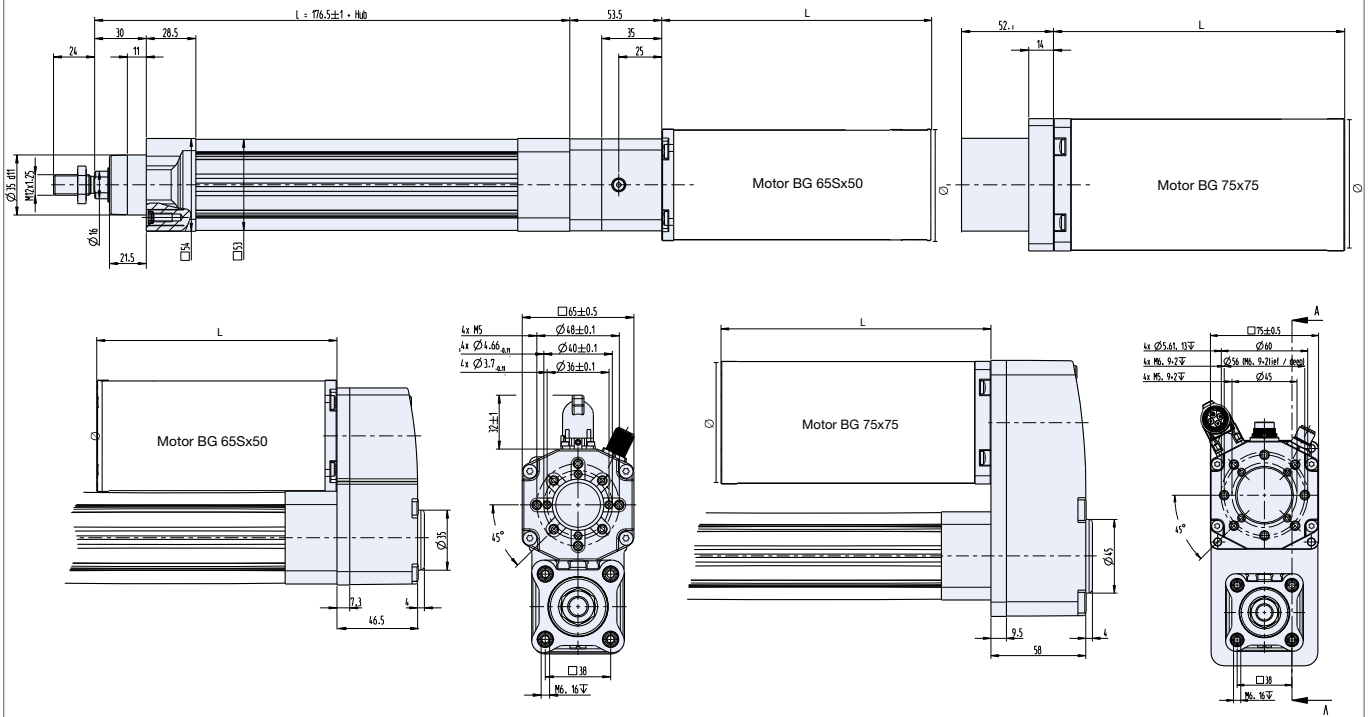

		BG 65Sx50	BG 75x75
Motor length/ Motorlänge L	mm	140	165
Motor Ø/ Motor Ø	mm	65	75

Characteristic diagram/ Belastungskennlinien @25°C

Load/ linear speed diagram

Load = force acting on the actuator
(gravity force + acceleration force + constant force)

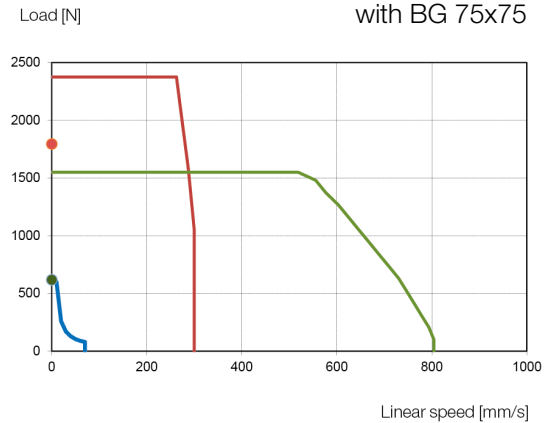
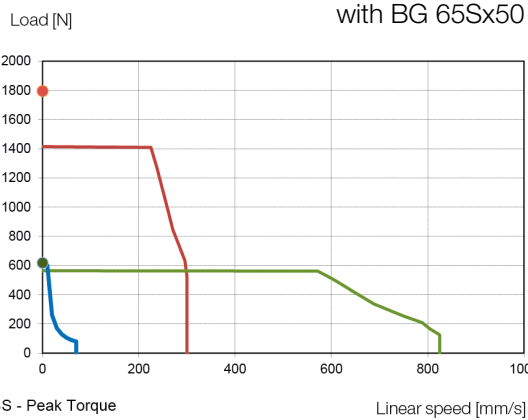



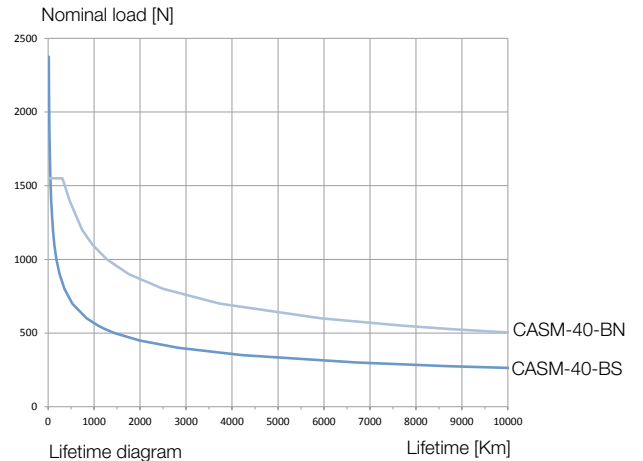
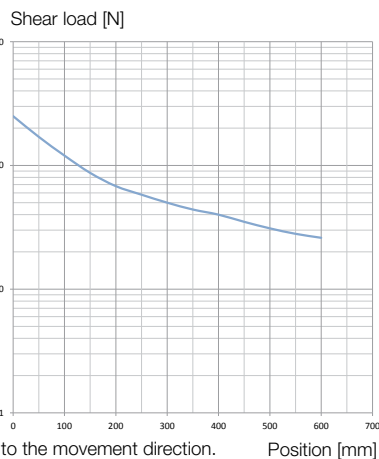







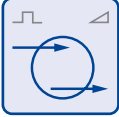

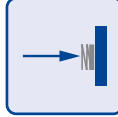
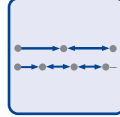



- CASM-40-BS - Peak Torque
- CASM-40-LS
- CASM-40-BN - Peak Torque
- Brake
- Brake

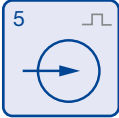
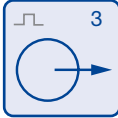
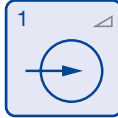

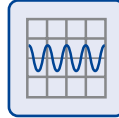
- » Electric cylinder with strokes up to 800 mm
- » With brushless DC servomotors
- » Lead and ball screw version
- » Twist protected thrust rod
- » In-line and parallel motor version
- » Alternative for pneumatic cylinder
- » Compact and space saving
- » Easy configuration of max. 14 positions (PI motor)
- » Several BUS interfaces available
- » PLG 63 on request

- » Elektrischer Hubzylinder mit Hube von bis zu 800 mm
- » Mit bürstenlosem DC-Servomotoren
- » Gleitspindel und Kugelrollspindel Versionen
- » Verdreh gesicherte Schubstange
- » In-Line und parallele Motorausführung
- » Alternative zu Pneumatik Zylinder
- » Kompakt und platzsparend
- » Einfache Konfiguration von bis zu 14 Positionen (PI Motor)
- » Verschiedene BUS-Schnittstellen verfügbar
- » Auf Anfrage mit PLG 63



									
IO mode	CANopen version available	Service interface	Force mode	Precise positioning	Maintenance free	High efficiency	Low noise	Self-locking ratios available	High force
									
High dynamic	Digital inputs	Digital outputs	Analog inputs	Feedback integrated	Oscilloscope software available	Condition monitoring	Programmable	Protection class (up to)	Supply voltage versions
									
Certification	Certification								

Data/ Technische Daten		CASM-63			
Motor type/ Motortyp		BG 75x75			
Nominal voltage/ Nennspannung	VDC	40-48			
Nominal current/ Nennstrom	A	12.7			
Peak current (2 sec.)/ Spitzenstrom (2 sec.)	A	50			
Spindle version/ Spindelversion	-	LS	BN	BF	
Spindle pitch/ Spindelsteigung	mm	4	10	20	
Constant force/ Dauerkraft	N	692	583	292	
Peak force/ Spitzenkraft	N	1000	1885	942	
Max. traverse speed/ Max. Verfahrengeschwindigkeit	mm/s	70	530	1060	
Max. acceleration/ Max. Beschleunigung	m/s ²	1	6		
Repeatability/ Wiederholgenauigkeit	mm	+/- 0.07	+/- 0.01		
Lifetime L ₁₀ / Lebensdauer L ₁₀	km	100	Siehe Diagramm		
Stroke length/ Hublängen	mm	100 / 200 / 300 / 400 / 500 / 800			

LS: Lead screw/ Gleitspindel *Not applicable for motions on mechanical stop./ Nicht geeignet für Bewegungen auf mechanischem Anschlag.*
 BF / BN: Ball screw/ Kugelrollspindel Preference/ Vorzugsreihe On request/ auf Anfrage

Dimensions/ Maßzeichnung

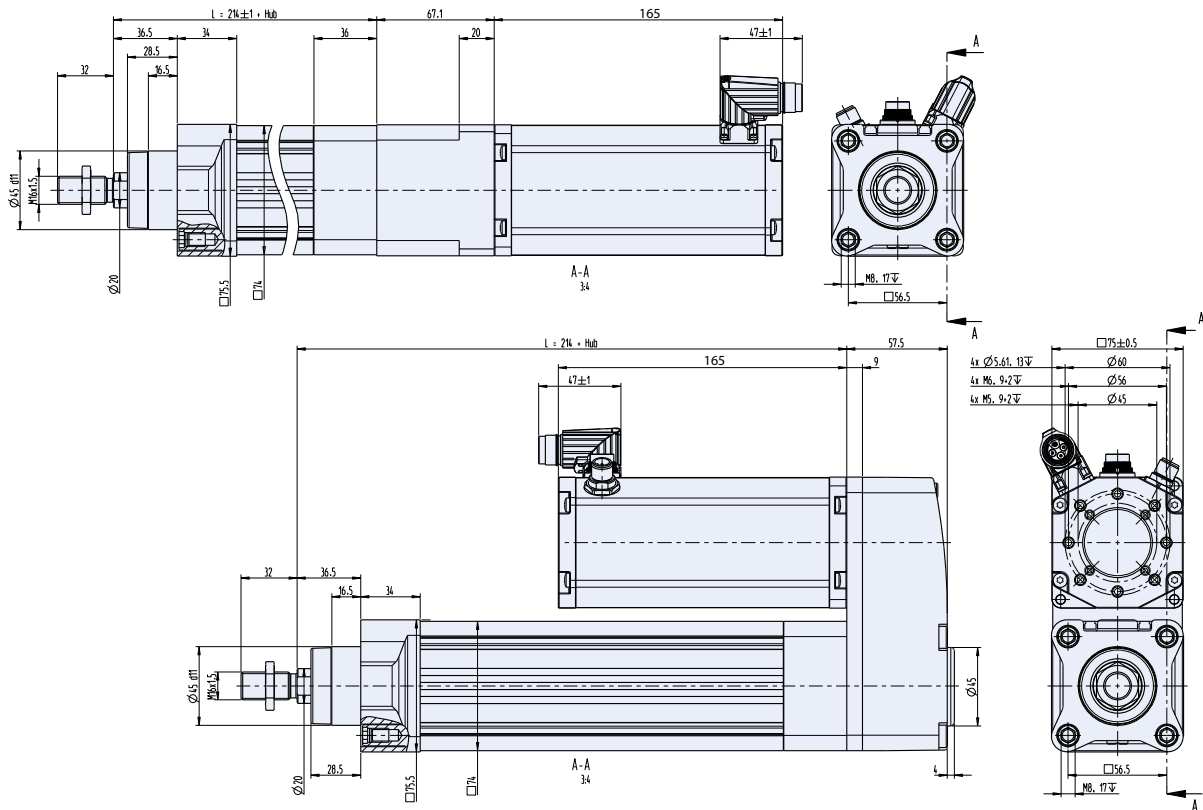

Characteristic diagram/ Belastungskennlinien @25°C

Load [N] Load/ linear speed diagram

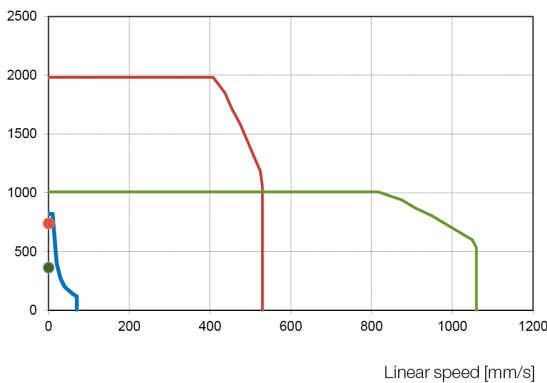

Load = force acting on the actuator (gravity force + acceleration force + constant force)

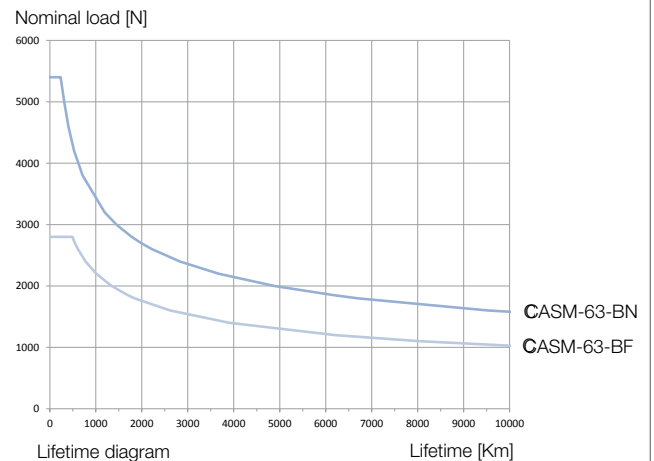
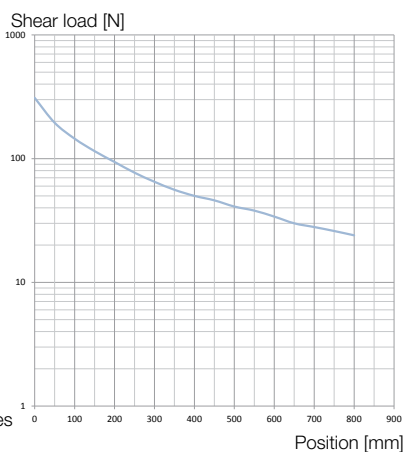

Foot mounting kit (for parallel version)/ Fussmontagesatz (für Parallel Version)

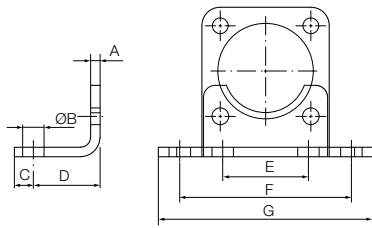

*Screws included

	SNR	A	B	C	D	E	F	G
CASM-32	28700.33321	4	7	11	24	32	58	71
CASM-40	28700.33401	4	9	8	28	36	72	90
CASM-63	28700.33631	5	9	13	32	50	92	110

Flange mounting kit/ Flanschbefestigung

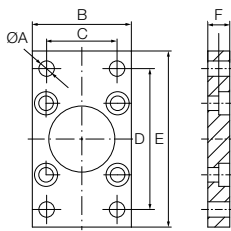

*Screws included

	SNR	A	B	C	D	E	F
CASM-32	28700.33322	7	45	32	64	80	10
CASM-40	28700.33402	9	52	36	72	90	10
CASM-63	28700.33632	9	75	50	100	120	12

Trunnion flange kit/ Schwenzapfenflansch

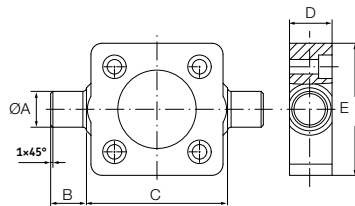

*Screws included

	SNR	A	B	C	D	E
CASM-32	28700.33323	12	12	50	14	46
CASM-40	28700.33403	16	16	63	19	59
CASM-63	28700.33633	20	20	90	24	84

Trunnion mounting kit/ Schwenzapfen

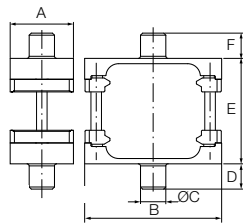

*Screws included

	SNR	A	B	C	D	E	F
CASM-32	28700.33324	30	65	12	12	50	12
CASM-40	28700.33404	32	75	16	16	63	16
CASM-63	28700.33634	41	105	20	20	90	20

Trunnion support kit/ Lagerblöcke (Paar)

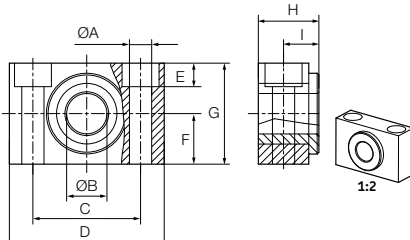

	SNR	A	B	C	D	E	F	G	H	I
CASM-32	28700.33325	6.6	12	32	46	6.8	15	30	18	10.5
CASM-40	28700.33405	9	16	36	55	9	18	36	21	12
CASM-63	28700.33635	11	20	42	65	11	20	40	23	13

Swivel flange (for parallel version)/ Gabelbefestigung (für Parallel Version)

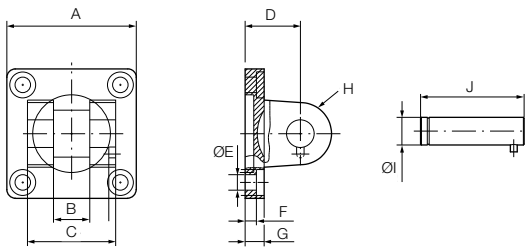

*Screws included

	SNR	A	B	C	D	E	F	G	H	I	J
CASM-32	28700.33326	45	14	34	22	6.6	5.5	9	10	10	41
CASM-40	28700.33406	52	16	40	25	6.6	5.5	9	12	12	48
CASM-63	28700.33636	75	21	51	32	9	6.5	11	18	16	60

Swivel flange with rod eye (for parallel version)/ Gelenklager (für Parallel Version)

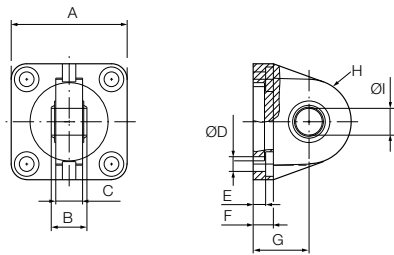

*Screws included

	SNR	A	B	C	D	E	F	G	H	I
CASM-32	28700.33327	45	14	10.5	6.6	5.5	9	22	16	10
CASM-40	28700.33407	52	16	12	6.6	5.5	9	25	19	12
CASM-63	28700.33637	75	21	15	9	6.5	11	32	24	16

Rod clevis/ Gabelkopf

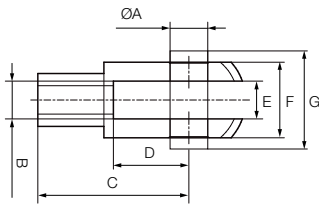

	SNR	A	B	C	D	E	F	G
CASM-32	28700.33328	10	M10x1.25	40	20	10	20	28
CASM-40	28700.33408	12	M12x1.25	48	24	12	24	32
CASM-63	28700.33638	16	M16x1.5	64	32	16	32	41.5

Rod eye/ Gelenkkopf

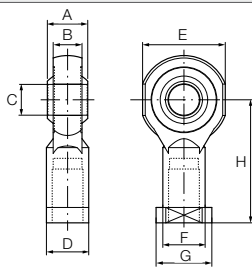

	SNR	A	B	C	D	E	F	G	H
CASM-32	28700.33329	14	10.5	10	17	29	15	20	43
CASM-40	28700.33409	16	12	12	19	33	17.5	23	50
CASM-63	28700.33639	21	15	16	22	43	22	29	64

Proximity sensor/ Näherungsschalter

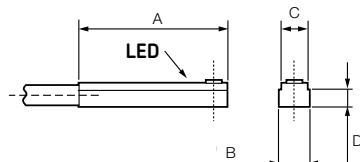

Switching function/ Schaltfunktion: Normally open
 Output signal/ Ausgangssignal: PNP
 Rated voltage/ Nennspannung: 24 VDC
 Max. current/ Max. Strom: 30 mA
 Cable length/ Kabellänge: 5 m

	SNR	A	B	C	D
CASM-32	28700.33320	29	6.2	5	3.15
CASM-40	28700.33320	29	6.2	5	3.15
CASM-63	28700.33320	29	6.2	5	3.15

Linear products