

Everything's possible.

FlexPro[®] Embedded Drives

Hardware Installation Manual



Preface

ADVANCED Motion Controls constantly strives to improve all of its products. We review the information in this document regularly and we welcome any suggestions for improvement. We reserve the right to modify equipment and documentation without prior notice.

For the most recent software, the latest revisions of this manual, and copies of compliance and declarations of conformity, visit the company's website at www.a-m-c.com. Otherwise, contact the company directly at:

ADVANCED Motion Controls • 3805 Calle Tecate Camarillo, CA • 93012-5068 USA

Agency Compliances

The company holds original documents for the following:

- UL 61800-5-1 file number E140173
- Electromagnetic Compatibility, EMC Directive - 2014/30/EU
EN61000-6-2:2005
EN61000-6-4:2007/A1:2011
Electrical Safety, Low Voltage Directive - 2014/35/EU
EN 60204-1:2019
- Reduction of Hazardous Substances (RoHS III), 2015/863/EU

Trademarks

ADVANCED Motion Controls®, the combined isosceles trapezoid/right triangle logo, and FlexPro® are registered trademarks of *ADVANCED* Motion Controls in the United States and/or other countries. EtherCAT® is a registered trademark and patented technology, licensed by Beckhoff Automation GmbH, Germany. All other trademarks are the property of their respective owners.

Related Documentation - available for download at www.a-m-c.com

- Product datasheet specific for your drive
- Software Startup Guide
- *ADVANCED* Motion Controls EtherCAT Communication Manual for FlexPro
- *ADVANCED* Motion Controls CANopen Communication Manual for FlexPro

© 2024 *ADVANCED* Motion Controls. All rights reserved.

Attention Symbols

The following symbols are used throughout this document to draw attention to important operating information, special instructions, and cautionary warnings. The section below outlines the overall directive of each symbol and what type of information the accompanying text is relaying.



Note

Note - Pertinent information that clarifies a process, operation, or ease-of-use preparations regarding the product.



Notice

Notice - Required instruction necessary to ensure successful completion of a task or procedure.



Caution

Caution - Instructs and directs you to avoid damaging equipment.



Warning

Warning - Instructs and directs you to avoid harming yourself.



DANGER

Danger - Presents information you must heed to avoid serious injury or death.

Revision History

Document ID	Revision #	Date	Changes
MNFPEMIN-01	1	4/2019	First Release
MNFPEMIN-02	2	10/2019	- Added FE060-10-EM, FE060-5-EM, FD060-10-EM, FD060-5-EM models
MNFPEMIN-03	3	1/2020	- Added FM060-5-EM, FM060-10-EM, FM060-25-EM models
MNFPEMIN-04	4	2/2020	- Added Extended Environment specifications
MNFPEMIN-05	5	10/2020	- Added CANopen models
MNFPEMIN-06	6	5/2021	- Added 100V/50A models
MNFPEMIN-07	7	9/2021	-Added 60A continuous models
MNFPEMIN-08	8	01/2022	-Added information regarding PC I/O expander requirements
MNFPEMIN-09	9	02/2022	-Added 100V-25A models
MNFPEMIN-10	10	04/2022	-Added Ethernet/IP information
MNFPEMIN-11	11	02/2023	-Added 60V/100A models
MNFPEMIN-12	12	02/2024	-Added SSI Feedback to CAN and Serial Models



Contents

1 Safety **1**

1.1 General Safety Overview	1
-----------------------------------	---

2 Products and System Requirements **4**

2.1 FlexPro® Embedded Drives Overview	4
2.2 Products Covered	5
2.3 Communication Protocols	7
2.3.1 EtherCAT	7
2.3.2 CANopen	7
2.3.3 RS485/232	8
2.3.4 Ethernet/IP	8
2.4 Control Modes	9
2.4.1 Profile Modes	9
2.4.2 Current (Torque) or Profile Current (Torque)	9
2.4.3 Velocity or Profile Velocity	9
2.4.4 Position or Profile Position	9
2.4.5 Cyclic Synchronous Modes	10
Cyclic Synchronous Current	10
Cyclic Synchronous Velocity	10
Cyclic Synchronous Position	10
2.4.6 Interpolated Position Mode (PVT)	10
2.5 Feedback Supported	10
Feedback Polarity	11
2.5.1 Absolute Encoder	11
2.5.2 Incremental Encoder Feedback	12
2.5.3 Hall Sensors	13

2.5.4 Auxiliary Incremental Encoder	14
2.5.5 Tachometer (± 10 VDC)	14
2.6 Command Sources	15
2.6.1 Over the Network	15
2.6.2 ± 10 V Analog	15
2.6.3 Encoder Following	15
2.6.4 Indexing and Sequencing	15
2.6.5 Jogging	15
2.7 Pinouts and Pin Layouts	16
2.7.1 P1 Signal Connector	16
2.7.2 FE060-xx-xx / FE100-25-xx Power Terminals	17
2.7.3 FE100-50-xx Power Terminals	18
2.8 System Requirements	19
2.8.1 Specifications Check	19
2.8.2 Motor Specifications	19
2.8.3 Power Supply Specifications	20
2.8.4 Environment	22
Ambient Temperature Range and Thermal Data	22
Shock/Vibrations	23
Extended Environment Models	23

3 Integration in the Servo System 24

3.1 LVD Requirements	24
3.2 CE-EMC Wiring Requirements	25
General	25
Analog Input Drives	25
PWM Input Drives	25
MOSFET Switching Drives	25
IGBT Switching Drives	25
Fitting of AC Power Filters	25
3.2.1 Ferrite Suppression Core Set-up	26
3.2.2 Inductive Filter Cards	26
3.2.3 Baseplate Isolation	26
3.3 Grounding	27
3.4 Wiring	28
3.4.1 Wire Gauge	28
3.4.2 Motor Wires	28
3.4.3 Power Supply Wires	29

3.4.4 Feedback Wires	29
3.4.5 Input Reference Wires	30
3.5 Mounting	31
3.5.1 Development and Interface Board Assemblies	31
3.6 PCB Design	33
3.6.1 Best Practice Design Recommendations and Requirements	33
Requirements	33
Best Practices	33
3.6.2 Trace Width and Routing	33
3.6.3 PCB Mounting Options	34
Signal Connector	34
Terminal Pins	34
Screw Mounting	34
3.6.4 Interface Circuitry Examples	35
USB Interface	35
Logic Supply Input	36
DC Power Input	36
Motor Power Output	37
Digital Inputs	38
Digital Outputs	38
Analog Inputs	39
Hall Sensor Inputs	39
Encoder Inputs	40
Auxiliary Encoder	40
STO (Safe Torque Off) Interface	41
EtherCAT Interface	43
Multi-Axis EtherCAT Interface	45
CANopen Interface	46
RS485/232 Interface	46
Ethernet/IP Interface	47
Motor Thermistor Input	49
I2C Data Signals	49

4 Operation and Features 52

4.1 Features and Getting Started	52
4.1.1 Initial Setup and Configuration	52
4.1.2 Input/Output Pin Functions	54

Motor Thermistor	54
Programmable Digital Inputs	54
Programmable Digital Outputs	54
Programmable Analog Input	54
4.1.3 EtherCAT Communication LEDs Functionality	54
4.1.4 Ethernet/IP Communication LEDs Functionality	55
4.1.5 Commutation	55
Sinusoidal Commutation	56
Trapezoidal Commutation	56
4.1.6 Firmware	57

A Specifications **59**

A.1 Specifications Tables	59
-------------------------------------	----

B Troubleshooting **61**

B.1 Fault Conditions and Symptoms	61
Over-Temperature	61
Over-Voltage Shutdown	61
Under-Voltage Shutdown	61
Short Circuit Fault	62
Invalid Hall Sensor State	62
B.1.1 Software Limits	62
B.1.2 Connection Problems	62
B.1.3 Overload	63
B.1.4 Current Limiting	63
B.1.5 Motor Problems	63
B.1.6 Causes of Erratic Operation	63
B.2 Technical Support	64
B.2.1 Drive Model Information	64
B.2.2 Product Label Description	64
B.2.3 Warranty Returns and Factory Help	65

Index I

1 Safety

This section discusses characteristics of your FlexPro drive to raise your awareness of potential risks and hazards. The severity of consequences ranges from frustration of performance, through damage to equipment, injury or death. These consequences, of course, can be avoided by good design and proper installation into your mechanism.

1.1 General Safety Overview

In order to install a drive into a servo system, you must have a thorough knowledge and understanding of basic electronics, computers and mechanics as well as safety precautions and practices required when dealing with the possibility of high voltages or heavy, strong equipment.

Observe your facility's lock-out/tag-out procedures so that work can proceed without residual power stored in the system or unexpected movements by the machine.



Notice

You must install and operate motion control equipment so that you meet all applicable safety requirements. Ensure that you identify the relevant standards and comply with them. Failure to do so may result in damage to equipment and personal injury.

Read this entire manual prior to attempting to install or operate the drive. Become familiar with practices and procedures that allow you to operate these drives safely and effectively. You are responsible for determining the suitability of this product for the intended application. The manufacturer is neither responsible nor liable for indirect or consequential damages resulting from the inappropriate use of this product.



Caution

Over current protective devices recognized by an international safety agency must be installed in line before the servo drive. These devices shall be installed and rated in accordance with the device installation instructions and the specifications of the servo drive (taking into consideration inrush currents, etc.). Servo drives that incorporate their own primary fuses do not need to incorporate over current protection in the end user's equipment.



Notice

High-performance motion control equipment can move rapidly with very high forces. Unexpected motion may occur especially during product commissioning. Keep clear of any operational machinery and never touch them while they are working.



Warning

Keep clear of all exposed power terminals (motor, DC Bus, shunt, DC power, transformer) when power is applied to the equipment. Follow these safety guidelines:

- When using a separate logic supply, turn on the logic power supply first before turning on the main power supply.
- Always turn off the main power and allow sufficient time for complete discharge before making any connections to the drive.
- Do not rotate the motor shaft without power. The motor acts as a generator and will charge up the power supply capacitors through the drive. Excessive speeds may cause over-voltage breakdown in the power output stage. Note that a drive having an internal power converter that operates from the high voltage supply will become operative.
- Do not short the motor leads at high motor speeds. When the motor is shorted, its own generated voltage may produce a current flow as high as 10 times the drive current. The short itself may not damage the drive but may damage the motor. If the connection arcs or opens while the motor is spinning rapidly, this high voltage pulse flows back into the drive (due to stored energy in the motor inductance) and may damage the drive.
- Do not make any connections to any internal circuitry. Only connections to designated connectors are allowed.
- Do not make any connections to the drive while power is applied.



Caution

- Do not reverse the power supply leads! Severe damage will result!
- If using relays or other means to disconnect the motor leads, be sure the drive is disabled before reconnecting the motor leads to the drive. Connecting the motor leads to the drive while it is enabled can generate extremely high voltage spikes which will damage the drive.
- When using a separate logic power supply, turn on the logic supply first before turning on the main power supply. When powering down, first remove the main power supply before turning off / removing the logic power.



Caution

Use sufficient capacitance!

Pulse Width Modulation (PWM) drives require a capacitor on the high voltage supply to store energy during the PWM switching process. Insufficient power supply capacitance causes problems particularly with high inductance motors. During braking much of the stored mechanical energy is fed back into the power supply and charges its output capacitor to a higher voltage. If the charge reaches the drive's over-voltage shutdown point, output current and braking will cease. At that time energy stored in the motor inductance continues to flow through diodes in the drive to further charge the power supply capacitance. The voltage rise depends upon the power supply capacitance, motor speed, and inductance.



Caution

Make sure minimum inductance requirements are met!

Pulse Width Modulation (PWM) servo drives deliver a pulsed output that requires a minimum amount of load inductance to ensure that the DC motor current is properly filtered. The minimum inductance values for different drive types are shown in the individual data sheet specifications. If the drive is operated below its maximum rated voltage, the minimum load inductance requirement may be reduced. Most servo-motors have enough winding inductance. Some types of motors (e.g. "basket-wound", "pancake", etc.) do not have a conventional iron core rotor, so the winding inductance is usually less than 50 μH .

If the motor inductance value is less than the minimum required for the selected drive, use an external filter card.

2 Products and System Requirements

This document is intended as a guide and general overview in selecting, installing, and operating a FlexPro[®] embedded digital servo drive. Contained within are instructions on system integration, wiring, drive-setup, and standard operating methods.

2.1 FlexPro[®] Embedded Drives Overview

FlexPro[®] embedded digital drives are designed to offer the same high performance and accuracy of larger drives, but in a space-saving PCB-mount architecture. By utilizing high density power devices, dual-sided PCB boards, and creative design FlexPro embedded drives are ideal for applications with limited size and weight constraints. The FlexPro embedded drive family can power three phase or single phase brushless or brushed servomotors, two phase or three phase closed loop stepper motors, and closed loop vector AC induction motors. FlexPro embedded drives are powered off a single isolated DC power supply, and provide a variety of control and feedback options. A digital controller can be used to command and interact with the drives, and a number of dedicated and programmable digital and analog input/output pins are available for parameter observation and drive configuration. FlexPro embedded drives are capable of operating in current (torque), velocity, or position modes, and utilize Space Vector Modulation, which results in higher bus voltage utilization and reduced heat dissipation compared to traditional PWM.

FlexPro embedded drives feature a communication interface for networking (drive model dependent), and USB connectivity for drive configuration and setup. The drive datasheet contains important information on the options and product-specific features available with a particular drive. The datasheet is to be used in conjunction with this manual for system design and installation and can be downloaded from www.a-m-c.com.

2.2 Products Covered

The products covered in this manual adhere to the following part numbering structure. Note that not all possible part number combinations are available as standard product offerings. Consult the servo drive selection tool on www.a-m-c.com for standard models. Additional features and/or options are readily available for OEM's with sufficient ordering volume. Feel free to contact *ADVANCED* Motion Controls for further information.

FIGURE 2.1 FlexPro Embedded Part Numbering Structure

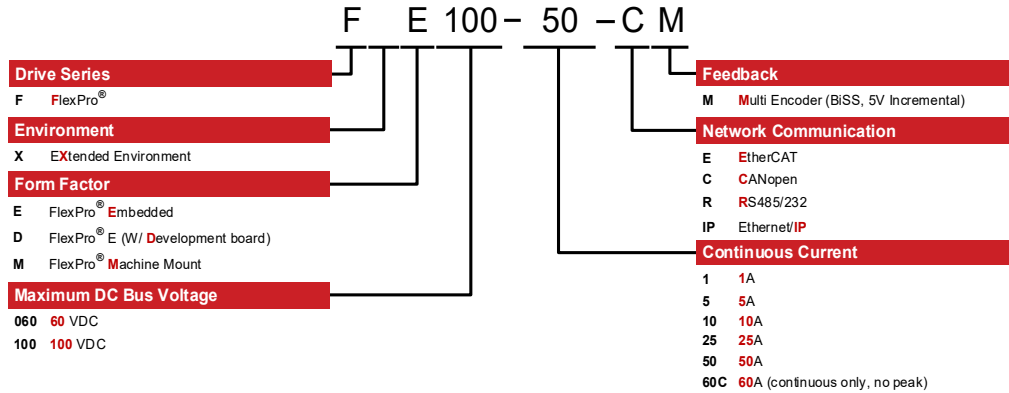

TABLE 2.1 Power Specifications - Micro Size Drives

Description	Units	Fxx060-1	Fxx060-5	Fxx060-10	Fxx060-25	Fxx060-60C	Fxx100-25
Nominal DC Supply Input Range	VDC	12 - 48	12 - 48	12 - 48	12 - 48	12 - 48	18 - 90
DC Supply Voltage Range	VDC	10 - 55	10 - 55	10 - 55	10 - 55	10 - 55	18 - 90
DC Bus Over Voltage Limit	VDC	58	58	58	58	58	95
DC Bus Under Voltage Limit	VDC	8	8	8	8	8	15
Logic Supply Voltage	VDC	10 - 55	10 - 55	10 - 55	10 - 55	10 - 55	10 - 55
Maximum Peak Output Current	A (A _{rms})	2 (1.4)	10 (7.1)	20 (14.1)	50 (35.3)	-	50 (35.3)
Maximum Continuous Output Current	A (A _{rms})	1 (1)	5 (5)	10 (10)	25 (25)	60 (60)	25 (25)
Maximum Continuous Output Power	W	54	272	545	1361	3267	2228
Maximum Power Dissipation at Rated Power	W	1	3	6	14	33	23
Minimum Load Inductance ¹	μH	150	150	150	150	150	150
Switching Frequency	kHz	20	20	20	20	20	20
Maximum Output PWM Duty Cycle	%	83	83	83	83	83	83

TABLE 2.2 Power Specifications - Mini Size Drives

Description	Units	Fxx100-50	Fxx060-100
Nominal DC Supply Input Range	VDC	20 - 90	10 - 55
DC Supply Voltage Range	VDC	20 - 90	10 - 55
DC Bus Over Voltage Limit	VDC	100	58
DC Bus Under Voltage Limit	VDC	15	9
Logic Supply Voltage	VDC	10 - 55	10 - 55
Maximum Peak Output Current	A (A _{rms})	100 (70.7)	200 (141.4)
Maximum Continuous Output Current	A (A _{rms})	50 (50)	100 (100)
Maximum Continuous Output Power	W	4455	5445
Maximum Power Dissipation at Rated Power	W	45	55
Minimum Load Inductance ¹	μH	250	250
Switching Frequency	kHz	20	20
Maximum Output PWM Duty Cycle	%	83	83

1. Lower inductance is acceptable for bus voltages well below minimum. Use external inductance to meet requirements.

TABLE 2.3 Control Specifications

Description	Fxxxx-xx-EM	Fxxxx-xx-IPM	Fxxx-xx-CM	Fxxx-xx-RM
Network Communication	EtherCAT (USB for configuration)	Ethernet/IP (USB for configuration)	CANopen (USB for configuration)	RS485/232 (USB for configuration)
Command Sources	±10V Analog, Over the Network, Encoder Following, Sequencing, Indexing, Jogging, Step & Direction			
Commutation Methods	Sinusoidal, Trapezoidal			
Control Modes	Profile Modes, Cyclic Synchronous Modes, Current, Velocity, Position	Profile Modes, Current, Velocity, Position	Profile Modes, Cyclic Synchronous Modes, Current, Velocity, Position, Interpolated Position Mode (PVT)	Current, Velocity, Position
Motors Supported	Three Phase (Brushless Servo), Single Phase (Brushed Servo, Voice Coil, Inductive Load), Stepper (2- or 3-phased Closed Loop), AC induction (Closed Loop Vector)			
Hardware Protection	40+ Configurable Functions, Over Current, Over Temperature (Drive & Motor), Over Voltage, Short Circuit (Phase-Phase & Phase-Ground), Under Voltage			
Programmable Digital I/O	4 Inputs, 3 Outputs			
Programmable Analog I/O	1 Input			
Feedback Supported	Hall Sensors, Incremental Encoder, Aux. Incremental Encoder, Absolute Encoder (BiSS C-Mode, EnDat2.2), Tachometer (±10 VDC)		Hall Sensors, Incremental Encoder, Aux. Incremental Encoder, Absolute Encoder (BiSS C-Mode, EnDat 2.2, Tamagawa/Nikon, SSI), Tachometer (±10 VDC)	

2.3 Communication Protocols

2.3.1 EtherCAT



Certain drive models offer networking capability through EtherCAT® communication. An auxiliary USB port is featured for configuring the drive through ACE (AMC Configuration Environment).

EtherCAT communication works by exchanging messages between a "host" and "nodes". The messages contain information on specific drive functions, each of which is defined by a group of objects. An object is roughly equivalent to a memory location that holds a certain value. The values stored in the drive's objects are used to perform the drive functions (current loop, velocity loop, position loop, I/O functions, etc.). For more detailed information on EtherCAT communication with FlexPro drives and a complete list of objects, consult the *ADVANCED* Motion Controls EtherCAT Communication Manual available for download at www.a-m-c.com.

The EtherCAT interface for *ADVANCED* Motion Controls' FlexPro drives follows the ETG.1000.6 EtherCAT Application Layer protocol specification and the ETG.6010 Implementation guideline for CiA402 drive profile (device profile for drives and motion control). ETG (EtherCAT Technology Group) is the organization that governs the EtherCAT standard. More information can be found at www.ethercat.org.

2.3.2 CANopen

Certain drive models offer networking capability through CANopen communication. An auxiliary USB port is featured for configuring the drive through ACE (AMC Configuration Environment).

CANopen communication works by exchanging messages between a "host" and "nodes". The messages contain information on specific drive functions, each of which is defined by a group of objects. An object is roughly equivalent to a memory location that holds a certain value. The values stored in the drive's objects are used to perform the drive functions (current loop, velocity loop, position loop, I/O functions, etc.). For more detailed information on CANopen communication with FlexPro drives and a complete list of objects, consult the *ADVANCED* Motion Controls CANopen Communication Manual available for download at www.a-m-c.com.

The CAN interface for *ADVANCED* Motion Controls FlexPro drives follows the CiA (CAN in Automation) 301 communications profile and the CiA 402 device profile. CiA is the non-profit organization that governs the CANopen standard. More information can be found at www.can-cia.org.

2.3.3 RS485/232

Certain drive models offer networking capability through RS485/232. An auxiliary USB port is featured for configuring the drive through ACE (AMC Configuration Environment).

ADVANCED Motion Controls' proprietary serial protocol is a byte-based, binary, master-slave standard to access drive "commands". The drive commands provide read or write access to drive parameters, with each command containing one or more parameters. Each command is assigned a unique index number, and parameters within a command are given offset values. As a result, parameters are referenced using a combination of the command index and parameter offset values. The serial protocol utilizes variable length commands to access one or more parameters within an index. On FlexPro drives, the serial interface is provided through a transmit pin and a receive pin. These pins should be connected to the appropriate locations on a serial cable connector, as specified by the serial protocol. The reference point for the serial signals is common with the signal ground of the drive. See "[RS485/232 Interface](#)" on page 46 for more information on the FlexPro drive serial interface connection. For more detailed information on RS-485/232 communication with FlexPro drives, consult the *ADVANCED* Motion Controls Serial Communication Manual.

2.3.4 Ethernet/IP

Certain drive models offer networking capability through Ethernet/IP communication. An auxiliary USB port is featured for configuring the drive through ACE (AMC Configuration Environment).

ADVANCED Motion Controls' Ethernet/IP drives operate based on a control state machine as defined by CANopen standards, where each state has a defined behavior. Other drive functionalities are also based on the motion control profile defined by CANopen standards. More advanced Ethernet/IP functionality such as CIP Motion and CIP Sync are not currently supported.

2.4 Control Modes

FlexPro embedded drives operate in a variety of operating modes. The setup and configuration parameters for these modes are commissioned through the setup software. See the *ADVANCED Motion Controls' Communication Manual* for the drive in use for appropriate mode configuration information.

2.4.1 Profile Modes

In Profile Modes, the trajectory is limited by the drive, using the Command Limiter values to limit the maximum command rate. If the host sends a large command step, the drive spreads the demand over some period of time to stay equal to or below the maximum defined rate.

2.4.2 Current (Torque) or Profile Current (Torque)

In Profile Current (Torque) Mode, the input command voltage controls the output current. The drive will adjust the output duty cycle to maintain the commanded output current. This mode is used to control torque for rotary motors (force for linear motors), but the motor speed is not controlled. The output current and other parameters can be monitored in the setup software through the digital oscilloscope function. The setup software also offers configuration of maximum and continuous current limit values.



Note

While in Current (Torque) Mode, the drive will maintain a commanded torque output to the motor based on the input reference command. Sudden changes in the motor load may cause the drive to output a high torque command with little load resistance, causing the motor to spin rapidly. Therefore, Current (Torque) Mode is recommended for applications using a digital position controller to maintain system stability.

2.4.3 Velocity or Profile Velocity

In Profile Velocity Mode, the input command voltage controls the motor velocity. This mode requires the use of a feedback element to provide information to the drive about the motor velocity. FlexPro embedded drives allow velocity control with either Hall Sensors or an encoder as the feedback element. The motor velocity and other parameters can be monitored in the setup software through the digital oscilloscope function. The feedback element being used for velocity control must be specified in the setup software, which also offers configuration of velocity limits. See [“Feedback Supported” on page 10](#) for more information on feedback devices.

2.4.4 Position or Profile Position

In Profile Position Mode, the input command voltage controls the actual motor position. This mode requires the use of a feedback element to provide information to the drive about the physical motor location. FlexPro embedded drives allow position control with either an encoder or $\pm 10V$ Position feedback. The motor position and other parameters can be monitored in the setup software through the digital oscilloscope function. The feedback element being used for position control must be specified in the setup software, which also

offers configuration of position limits. See “[Feedback Supported](#)” on page 10 for more information on feedback devices.

2.4.5 Cyclic Synchronous Modes

Cyclic Synchronous Modes give responsibility of trajectory control to the host. The drive interpolates between command points, defining the rate by dividing the change in command by the interpolation time period. This allows the drive to respond smoothly to each step in command.

Cyclic Synchronous Current In Cyclic Synchronous Current Mode, the drive closes the current loop. The host is allowed more control by having the ability to instantly add current feedforward values. This allows for gain compensation in applications with varying loads.

Cyclic Synchronous Velocity In Cyclic Synchronous Velocity Mode, the drive closes two control loops: velocity and current. The host is allowed more control by having the ability to instantly add velocity and current feedforward values. This allows for gain compensation in applications with varying loads.

Cyclic Synchronous Position In Cyclic Synchronous Position Mode, the drive closes three control loops: position, velocity, and current. The host can send target position, velocity feedforward, and current feedforward values to the drive. This allows for gain compensation in applications with varying loads.

2.4.6 Interpolated Position Mode (PVT)

For FlexPro drives that use CANopen communication, Interpolated Position Mode (PVT) is typically used to stream motion data between multiple axes for coordinated motion. Arbitrary position and velocity profiles can be executed on each axis. A PVT command contains the position, velocity and time information of the motion profile’s segment end points. The drive performs a third order interpolation between segment end points, resulting in a partial trajectory generation where both host controller and drive generate a specific portion of the overall move profile trajectory. The host controller calculates position and velocity of intermittent points on the overall trajectory, while the drive interpolates between these intermittent points to ensure smooth motion. The actual position loop is closed within the drive. This reduces the amount of commands that need to be sent from host controller to drive, which is critical in distributed control systems. For more information on how to operate a FlexPro drive in PVT mode, consult the ACE Software Manual.

2.5 Feedback Supported

FlexPro drives support a variety of primary feedback devices. Compatible devices are Incremental Encoders, Absolute Encoders (BiSS C-Mode, EnDat 2.2, Tamagawa/Nikon, SSI), Hall Sensors, and Tachometer Position feedback. Consult the drive datasheet for the specific feedback types supported.

Feedback Polarity The feedback element must be connected for *negative* feedback. This will cause a difference between the command signal and the feedback signal, called the *error signal*. The drive compares the feedback signal to the command signal to produce the required output to the load by continually reducing the error signal to zero. This becomes important when using encoder or Hall Sensor feedback, as connecting these feedback elements for positive feedback will lead to a motor "run-away" condition. In a case where the feedback lines are connected to the drive with the wrong polarity, the drive will attempt to correct the "error signal" by applying more command to the motor. With the wrong feedback polarity, this will result in a positive feedback run-away condition. To correct this, either change the order that the feedback lines are connected to the drive, or use DriveWare to reverse the internal velocity feedback polarity setting. The AutoCommutation routine in DriveWare will typically determine the proper feedback polarity setting.

2.5.1 Absolute Encoder

Depending on the model, FlexPro embedded drives support either BiSS C-Mode, EnDat 2.2, Tamagawa/Nikon, or SSI absolute encoders for velocity and absolute position feedback. The number of turns, justification, resolution and other options can be configured within the setup software. Encoder position data is polled by the drive at a rate that is synchronous with the position loop.



Note

The absolute position feedback eliminates the need for a homing routine when the drive is powered on.



Note

For BiSS-C absolute encoders, FlexPro drives require the following performance metrics:

- Ensure the data transaction of the encoder occurs within 16 μ s. Use the pre-trigger to extend this window for encoders with longer transactions.
- Ensure the total time consumed for the ack time, data transaction, and timeout is within 45 μ s.

For BiSS-C encoders that do not meet these specifications, contact technical support.



Note

For SSI absolute encoders: FlexPro drives require the following performance metrics:

- SSI Encoders with status bits are currently not supported.
- The request rate of the drive is fixed at 50 μ s, the encoder must have a minimum request rate of at least this rate.
- The total data transaction of the encoder must occur within 31 μ s

For SSI encoders that do not meet these specifications, contact technical support.

2.5.2 Incremental Encoder Feedback

FlexPro embedded drives can utilize differential incremental encoder inputs for velocity or position control, with the option of also using the encoder to commutate the motor. The encoder provides incremental position feedback that can be extrapolated into very precise velocity or position information. With an encoder being used as the feedback element, the input command controls the motor velocity or motor position, with the frequency of the encoder signal closing either the velocity or position loop. The encoder signals are read as "pulses" that the drive uses to essentially keep track of the motor's speed, position and direction of rotation. Based on the speed and order in which these pulses are received from the encoder, the drive can interpret the motor velocity and physical location. The actual motor speed and physical location can be monitored in the setup software through the digital oscilloscope function. Both the "A" and "B" channels of the encoder are required for operation. FlexPro drives also accept an optional differential "index" channel that can be used for synchronization and/or homing.



Note

Users designing their own PCB interface may also design the appropriate circuitry on their PCB interface to allow single-ended inputs. See ["Encoder Inputs" on page 40](#) for circuitry recommendation.

[Figure 2.2](#) below represents differential encoder "pulse" signals, showing how dependent on which signal is read first and at what frequency the "pulses" arrive, the speed and direction of the motor shaft can be extrapolated. By keeping track of the number of encoder "pulses" with respect to a known motor "home" position, FlexPro drives are able to ascertain the actual motor location.

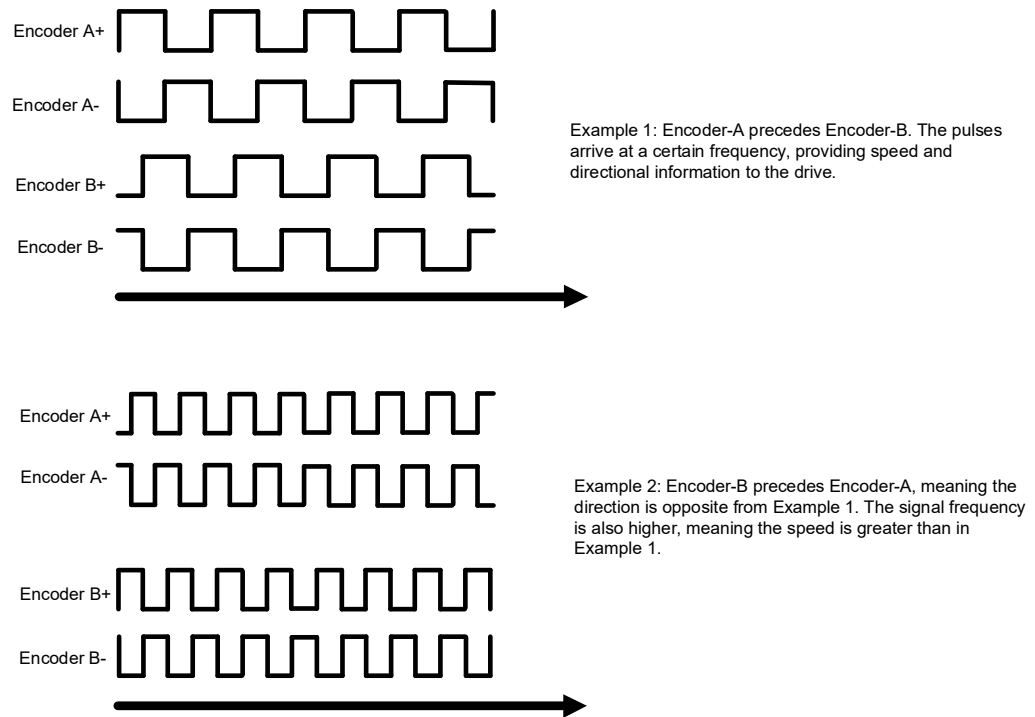
FIGURE 2.2 Encoder Feedback Signals

FlexPro drives can also use encoder feedback for sinusoidal commutation by using the AutoCommutation routine in the setup software. Encoder feedback is also used in the "Phase Detect" procedure, which is necessary when using a three phase (brushless) motor without Hall Sensors. Phase Detect works by sending a small current signal to the motor, prompting the motor to vibrate slightly for a few seconds. The encoder feedback from this movement provides a starting position for the motor, allowing the drive to then be properly commutated. See the setup software manual for more information on Phase Detect.



Note

The high resolution of motor mounted encoders allows for excellent velocity and position control and smooth motion at all speeds. Encoder feedback should be used for applications requiring precise and accurate velocity and position control, and is especially useful in applications where low-speed smoothness is the objective.

2.5.3 Hall Sensors

FlexPro drives can use single-ended Hall Sensors for commutation and/or velocity control. The Hall Sensors (typically three) are built into the motor to detect the position of the rotor magnetic field. With Hall Sensors being used as the feedback element, the input command voltage controls the motor velocity, with the Hall Sensor frequency closing the velocity loop. The Hall Sensor frequency is converted into velocity feedback that the drive uses to control the

motor speed and direction. The actual motor speed can be monitored in DriveWare through the digital oscilloscope function.



Note

Due to the inherent low resolution of motor mounted Hall Sensors, using Hall Sensors for velocity feedback is not recommended for low-speed applications below 300 rpm for a 6-pole motor, 600 rpm for a 4-pole motor, or 900 rpm for a 2-pole motor. Hall Velocity Mode is better suited for velocity control applications where the motor will be spinning at higher speeds.

For more information on using Hall Sensors for trapezoidal commutation, see [“Trapezoidal Commutation” on page 56](#).

2.5.4 Auxiliary Incremental Encoder

The auxiliary encoder input pins can be used as a command source for encoder following mode, or as a secondary feedback device input for closing the position loop. The particular function is configured in the setup software.

2.5.5 Tachometer (± 10 VDC)

FlexPro drives support the use of a tachometer for velocity feedback. The tachometer measures the rotary speed of the motor shaft and returns an analog voltage signal to the drive for velocity control. FlexPro drives provide a Programmable Analog Input that is available for use with a tachometer. The tachometer signal is limited to ± 10 VDC.

2.6 Command Sources

The input command source for FlexPro embedded drives can be provided by one of the following options.

2.6.1 Over the Network

FlexPro drives can utilize network communication as a form of input communication. For more information on EtherCAT or CANopen, see [“Communication Protocols” on page 7](#).

2.6.2 $\pm 10V$ Analog

FlexPro drives accept a differential or single-ended analog signal with a range of $\pm 10 V$ from an external source. The input command signals should be connected to pins P1-3 and P1-5. See [“Programmable Analog Input” on page 54](#) for more information.

2.6.3 Encoder Following

FlexPro drives can utilize Encoder Following as a form of input command. In Encoder Following mode, an auxiliary differential encoder signal can be used to command the drive in a master/slave configuration. The gearing ratio (input counts to output counts ratio) can be configured in the setup software by the user. Encoder Following is only a valid option when the drive is operated in position mode. The auxiliary encoder signal input should be connected to the ENC 2 pins. See [“Auxiliary Encoder” on page 40](#) for more information.

2.6.4 Indexing and Sequencing

FlexPro drives allow configuration of up to 16 separately defined Index tasks in the setup software. Indexes can be either Absolute (commands a pre-defined move to an absolute position) or Relative (commands a pre-defined move relative to the current position). Indexes can be combined with Homing routines and other control functions to form up to 16 different Sequences. Sequences can be configured to initiate on power-up, via a digital input, or by using an external network command.

2.6.5 Jogging

FlexPro drives allow configuration of four separate Jog velocities in the setup software, commanding motion at a defined constant velocity with infinite distance.

2.7 Pinouts and Pin Layouts

2.7.1 P1 Signal Connector

P1 - Signal Connector EtherCAT and Ethernet/IP Models			
Pin	Description	Pin	Description
1	GROUND	2	GROUND
3	PAI-1+	4	DATA+ USB
5	PAI-1-	6	DATA- USB
7	THERMISTOR	8	GROUND
9	GROUND	10	SCLA
11	ENC 1 DATA + / A+	12	SDAA
13	ENC 1 DATA - / A-	14	HALL A
15	ENC 1 CLK+ / B+	16	HALL B
17	ENC 1 CLK- / B-	18	HALL C
19	GROUND	20	GROUND
21	ENC 1 REF+ / I+	22	ENC 2 A+
23	ENC 1 REF- / I-	24	ENC 2 A-
25	RESERVED / NET_STATUS	26	ENC 2 B+
27	RESERVED	28	ENC 2 B-
29	RESERVED	30	ENC 2 I+
31	PDI-1	32	ENC 2 I-
33	PDI-2	34	PDO-1
35	PDI-3	36	PDO-2
37	PDI-4	38	PDO-3
39	GROUND	40	GROUND
41	TX- IN	42	TX- OUT
43	TX+ IN	44	TX+ OUT
45	RX- IN	46	RX- OUT
47	RX+ IN	48	RX+ OUT
49	+3V BIAS IN	50	+3V BIAS OUT
51	LINK/ACT IN	52	LINK/ACT OUT
53	STATUS/MOD_STATUS	54	RESERVED
55	RESERVED	56	RESERVED
57	RESERVED	58	RESERVED
59	GROUND	60	GROUND
61	RESERVED	62	RESERVED
63	RESERVED	64	RESERVED
65	RESERVED	66	RESERVED
67	RESERVED	68	STEP
69	RESERVED	70	DIR
71	RESERVED	72	RESERVED
73	+5V	74	RESERVED
75	+5V USER	76	+3V3
77	+5V USER	78	+3V3
79	GROUND	80	GROUND

P1 - Signal Connector CANopen and Serial Models			
Pin	Description	Pin	Description
1	GROUND	2	GROUND
3	PAI-1+	4	DATA+ USB
5	PAI-1-	6	DATA- USB
7	THERMISTOR	8	GROUND
9	GROUND	10	SCLA
11	ENC 1 DATA + / A+	12	SDAA
13	ENC 1 DATA - / A-	14	HALL A
15	ENC 1 CLK+ / B+	16	HALL B
17	ENC 1 CLK- / B-	18	HALL C
19	GROUND	20	GROUND
21	ENC 1 REF+ / I+	22	ENC 2 A+
23	ENC 1 REF- / I-	24	ENC 2 A-
25	CAN_TX / RS485/232 RX	26	ENC 2 B+
27	CAN_RX / RS485/232 TX	28	ENC 2 B-
29	CAN STANDBY / RS485 DIR CTRL	30	ENC 2 I+
31	PDI-1	32	ENC 2 I-
33	PDI-2	34	PDO-1
35	PDI-3	36	PDO-2
37	PDI-4	38	PDO-3
39	GROUND	40	GROUND
41	RESERVED	42	RESERVED
43	RESERVED	44	RESERVED
45	RESERVED	46	RESERVED
47	RESERVED	48	RESERVED
49	RESERVED	50	RESERVED
51	RESERVED	52	RESERVED
53	RESERVED	54	RESERVED
55	RESERVED	56	RESERVED
57	RESERVED	58	RESERVED
59	GROUND	60	GROUND
61	RESERVED	62	RESERVED
63	RESERVED	64	RESERVED
65	RESERVED	66	RESERVED
67	RESERVED	68	STEP
69	RESERVED	70	DIR
71	RESERVED	72	RESERVED
73	+5V	74	RESERVED
75	+5V USER	76	+3V3
77	+5V USER	78	+3V3
79	GROUND	80	GROUND

2.7.2 FE060-xx-xx / FE100-25-xx Power Terminals

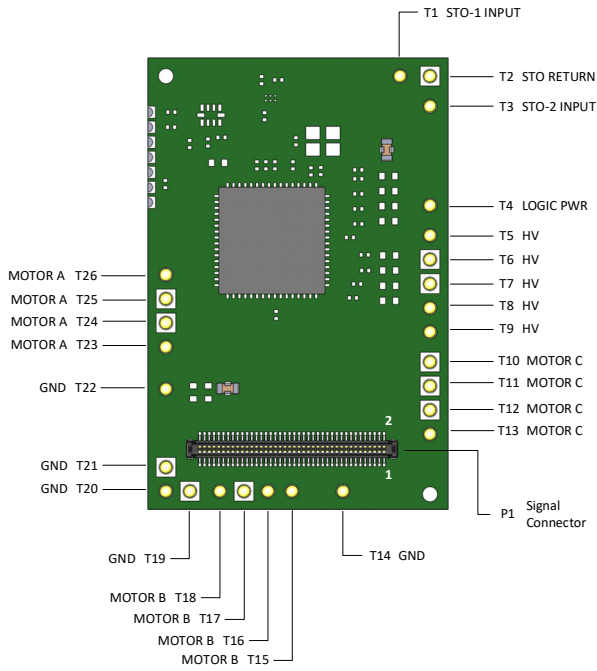

Terminal Pins	
Pin	Description
T1	STO-1 INPUT
T2	STO RETURN
T3	STO-2 INPUT
T4	LOGIC PWR
T5	HV
T6	
T7	
T8	
T9	
T10	MOTOR C
T11	
T12	
T13	POWER GND
T14	
T15	MOTOR B
T16	
T17	
T18	
T19	POWER GND
T20	
T21	
T22	MOTOR A
T23	
T24	
T25	
T26	

2.7.3 FE100-50-xx Power Terminals

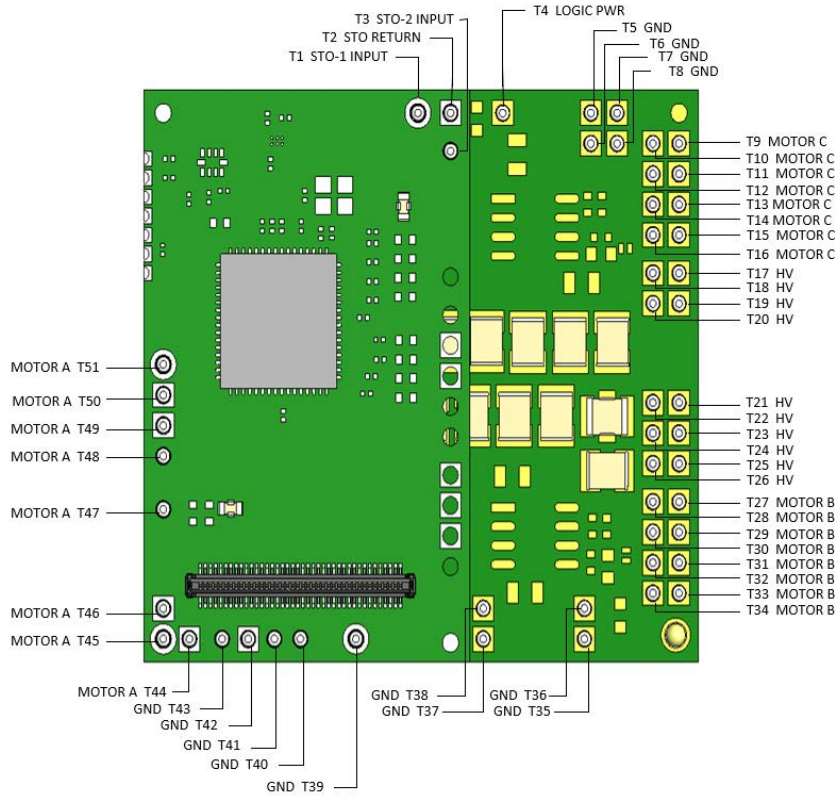

Terminal Pins	
Pin	Description
T1	STO-1 INPUT
T2	STO RETURN
T3	STO-2 INPUT
T4	LOGIC PWR
T5	POWER GND
T6	
T7	
T8	
T9	MOTOR C
T10	
T11	
T12	
T13	
T14	
T15	
T16	HV
T17	
T18	
T19	
T20	
T21	
T22	
T23	
T24	
T25	
T26	

Terminal Pins	
Pin	Description
T27	MOTOR B
T28	
T29	
T30	
T31	
T32	
T33	
T34	POWER GND
T35	
T36	
T37	
T38	
T39	
T40	
T41	MOTOR A
T42	
T43	
T44	
T45	
T46	
T47	
T48	
T49	
T50	
T51	

2.8 System Requirements

To successfully incorporate a FlexPro servo drive into your system, you must be sure it will operate properly based on electrical, mechanical, and environmental specifications while anticipating impacts on performance.

2.8.1 Specifications Check

Before selecting a FlexPro servo drive, a user should consider the requirements of their system. This involves calculating the voltage, current, torque, and power requirements of the system, as well as considering the operating environment and any other equipment the drive will be interfacing with. Before attempting to install or operate a servo drive, be sure all the following items are available:

- FlexPro Servo Drive
- Drive Datasheet (specific to your model)
- FlexPro Embedded Hardware Installation Manual
- Setup Software Manual



Note

FlexPro servo drives are shipped with no other connectors or mounting components other than the signal and terminal pins on the drive PCB itself. However, mounting cards and mating connectors are available. See [“Development and Interface Board Assemblies” on page 31](#) for the ADVANCED Motion Controls FlexPro development board assembly. Customized mounting options are also available for orders with sufficient volume.

2.8.2 Motor Specifications

FlexPro servo drives have a given current and voltage rating unique to each drive. Based on the necessary application requirements and the information from the datasheet of the motor being used, a drive may be selected that will best suit the motor capabilities. Some general guidelines that are useful when pairing a servo drive with a motor:

- The **motor current** I_M is the required motor current in amps DC, and is related to the torque needed to move the load by the following equation:

$$I_M = \frac{\text{Torque}}{K_T}$$

Where:

K_T -motor torque constant

The motor current will need to be calculated for both continuous and peak operation. The peak torque will be during the acceleration portion of the move profile. The continuous torque is the average torque required by the system during the move profile, including dwell times.

- The system voltage requirement is based on the motor properties and how fast and hard the motor is driven. The system voltage requirement is equal to the **motor voltage, V_M** , required to achieve the move profile.

$$V_M = (K_E \cdot S_M) + (I_M \cdot R_M)$$

Where:

- K_E -motor back EMF constant
- S_M -motor speed (use the maximum speed expected for the application)
- I_M -motor current (use the maximum current expected for the application)
- R_M -motor line-to-line resistance

- The motor inductance is vital to the operation of servo drives, as it ensures that the DC motor current is properly filtered.



Caution

A motor that does not meet the rated minimum inductance value of the drive may damage the drive! If the motor inductance value is less than the minimum required for the selected drive, use of an external filter card is necessary.

A minimum motor inductance rating can be found on the drive datasheet. If the drive is operated below the maximum rated voltage, the minimum load inductance requirement may be reduced.

2.8.3 Power Supply Specifications

FlexPro embedded servo drives operate off an isolated unregulated DC Power Supply (see [Table 2.1](#) for drive model power supply ranges and over-voltage shutdown values). To avoid nuisance over- or under-voltage errors caused by fluctuations in the power supply, the system power supply voltage should be at least 10% above the entire system voltage requirement, and at least 10% below the lowest value of the following:

- Drive over voltage
- External shunt regulator turn-on voltage

Use of a shunt regulator is necessary in systems where motor deceleration or a downward motion of the motor load will cause the system's mechanical energy to be regenerated via the drive back onto the power supply. This regenerated energy can charge the power supply capacitors to levels above that of the drive over-voltage shutdown level. If the power supply capacitance is unable to handle this excess energy, or if it is impractical to supply enough capacitance, then an external shunt regulator must be used to dissipate the regenerated energy. The shunt regulator will "turn-on" at a certain voltage level (set below the drive over-voltage shutdown level) and discharge the regenerated electric energy in the form of heat.

The power supply current rating is based on the maximum current that will be required by the system. If the power supply powers more than one drive, then the current requirements for each drive should be added together. Due to the nature of servo drives, the current into the drive does not always equal the current out of the drive. However, the *power* in is equal to the

power out. Use the following equation to calculate the **power supply output current, I_{PS}** , based on the motor current requirements.

$$I_{PS} = \frac{V_M \cdot I_M}{V_{PS} \cdot (0.98)}$$

Where:

V_{PS} -nominal power supply voltage
 I_M -motor current
 V_M -motor voltage

Use values of V and I at the point of maximum power in the move profile (when $V_M I_M = \max$). This will usually be at the end of a hard acceleration when both the torque and speed of the motor is high.

For stable operation during high dynamic moves, the power supply output impedance must be lower than:

$$\frac{P_{MP}}{2(I_{PDC})^2}$$

Where:

P_{MM} - Peak Motor Power
 I_{PDC} - Peak DC Input Current

This includes impedance from cabling, filters, etc.

2.8.4 Environment

To ensure proper operation of a FlexPro servo drive, it is important to evaluate the operating environment prior to installing the drive.

TABLE 2.4 Standard Environmental Specifications

Parameter	Description
Ambient Operating Temperature Range	0 - 65 °C (32 - 149 °F)
Storage Temperature Range	-40 - 85 °C (-40 - 185 °F)
Relative Humidity	0-95%, non-condensing

Ambient Temperature Range and Thermal Data FlexPro drives contain a built-in over-temperature disabling feature if the PCB temperature rises above the maximum PCB operating temperature value. For a nominal DC supply voltage and a specific output current, Figure 2.3 below specifies an upper limit to the ambient temperature range FlexPro drives can operate within while keeping the baseplate temperature below the thermal shutdown value. It is recommended to mount the baseplate of the drive to a heatsink for best thermal management results.



Warning

For certain models, additional cooling and/or heatsink may be required to achieve rated performance. Repeated over temperature events may cause damage to the drive due to the drive's high power density. Ensure that proper thermal management is adhered to during drive operation.

FIGURE 2.3 FlexPro Drives Maximum Ambient Temperature Range (Standard Environment Models)

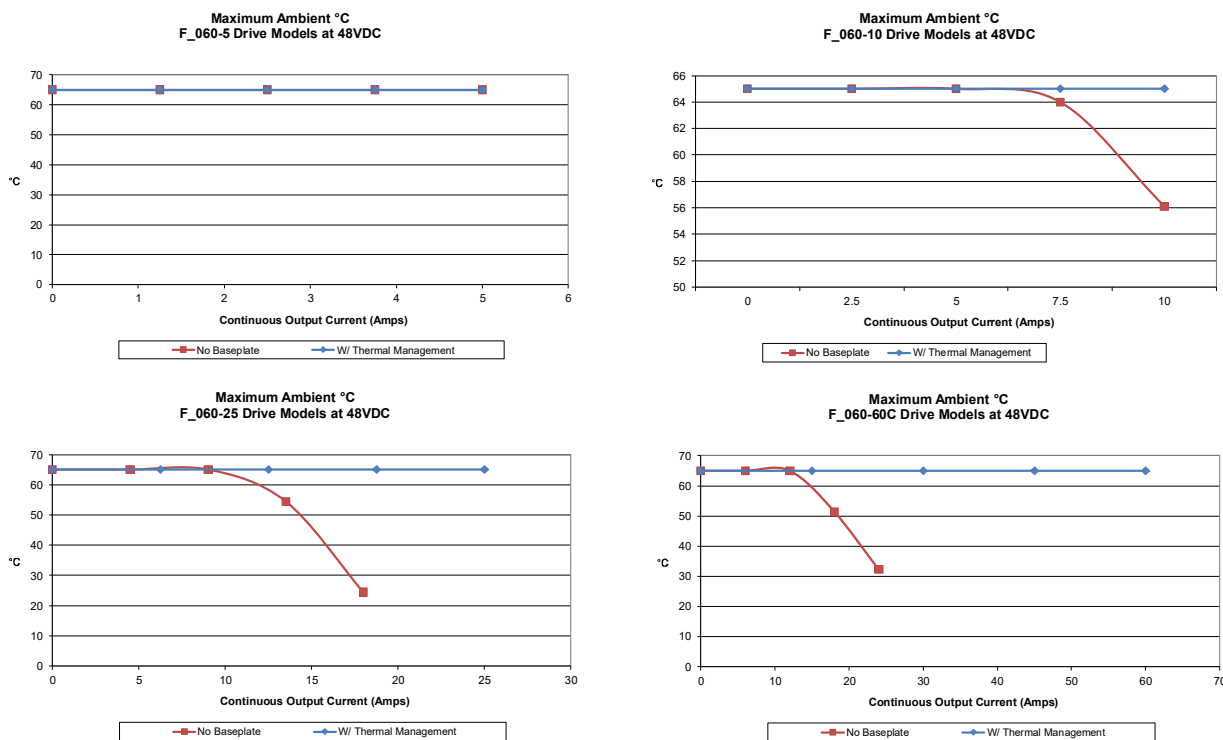

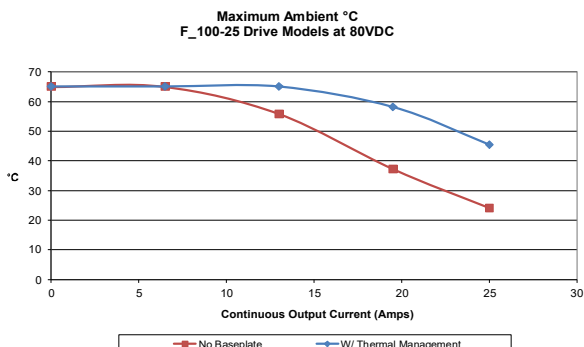
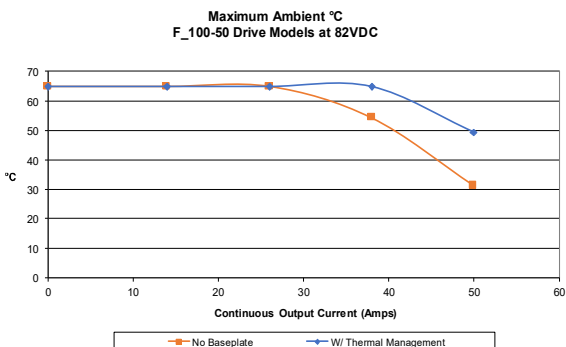

Shock/Vibrations While FlexPro drives are designed to withstand a high degree of mechanical shock and vibration, too much physical abuse can cause erratic behavior, or cause the drive to cease operation entirely. Be sure the drive is securely mounted in the system to reduce the shock and vibration the drive will be exposed to. The best way to secure the drive against mechanical vibration is to use screws to mount the drive against its baseplate. For information on mounting options and procedures, see “Mounting” on page 31.

Extended Environment Models FlexPro Extended Environment models (FX... part numbers) conform to the following specifications and are designed to the Environmental Engineering Considerations as defined in MIL-STD-810F.

TABLE 2.5 Extended Environmental Specifications

Parameter	Description
Ambient Operating Temperature Range	-40 - 95 °C (-40 - 203 °F)
Storage Temperature Range	-50 - 100 °C (-58 - 212 °F)
Relative Humidity	0-95%, non-condensing
Thermal Shock	-40 - 95 °C (-40 - 203 °F) within 3 min
Vibration	25 Grms for 5 minutes in 3 axes
Altitude	-400m to +25000m
Contaminants	Pollution Degree 2

In addition, FlexPro Extended Environment models are designed to optionally assist an end-user application towards meeting the following certifications:

- MIL-STD-1275D
- MIL-STD-461E
- MIL-STD-704F
- MIL-HDBK-217



Caution

Care should be taken to ensure the drive is securely mounted in a location where no moving parts will come in contact with the drive.

3

Integration in the Servo System

This chapter will give various details on incorporating a FlexPro® servo drive into a system, such as how to design the PCB traces on an interface board, how to properly ground the drive, and how to properly connect motor wires, power supply wires, feedback wires, communication cables, and inputs into the servo drive.

3.1 LVD Requirements

The servo drives covered in the LVD Reference report were investigated as components intended to be installed in complete systems that meet the requirements of the Machinery Directive. In order for these units to be acceptable in the end users' equipment, the following conditions of acceptability must be met.

1. European approved overload and current protection must be provided for the motors as specified in section 7.2 and 7.3 of EN60204.1.
2. A disconnect switch shall be installed in the final system as specified in section 5.3 of EN60204.1.
3. All drives that do not have a grounding terminal must be installed in, and conductively connected to a grounded end use enclosure in order to comply with the accessibility requirements of section 6, and to establish grounding continuity for the system in accordance with section 8 of EN60204.1.
4. A disconnecting device that will prevent the unexpected start-up of a machine shall be provided if the machine could cause injury to persons. This device shall prevent the automatic restarting of the machine after any failure condition shuts the machine down.
5. European approved over current protective devices must be installed in line before the servo drive, these devices shall be installed and rated in accordance with the installation instructions (the installation instructions shall specify an over current rating value as low as possible, but taking into consideration inrush currents, etc.). Servo drives that incorporate their own primary fuses do not need to incorporate over protection in the end users' equipment.

These items should be included in your declaration of incorporation as well as the name and address of your company, description of the equipment, a statement that the servo drives must not be put into service until the machinery into which they are incorporated has been declared in conformity with the provisions of the Machinery Directive, and identification of the person signing.

3.2 CE-EMC Wiring Requirements

The following sections contain installation instructions necessary for meeting EMC requirements.

Contact the factory for assistance in determining the type of drive in use.

General

1. Shielded cables must be used for all interconnect cables to the drive and the shield of the cable must be grounded at the closest ground point with the least amount of resistance.
2. The drive's metal enclosure must be grounded to the closest ground point with the least amount of resistance.
3. The drive must be mounted in such a manner that the connectors and exposed printed circuit board are not accessible to be touched by personnel when the product is in operation. If this is unavoidable there must be clear instructions that the amplifier is not to be touched during operation. This is to avoid possible malfunction due to electrostatic discharge from personnel.

Analog Input Drives

4. A Fair Rite model 0443167251 round suppression core must be fitted to the low level signal interconnect cables to prevent pickup from external RF fields.

PWM Input Drives

5. A Fair Rite model 0443167251 round suppression core must be fitted to the PWM input cable to reduce electromagnetic emissions.

MOSFET Switching Drives

6. A Fair Rite model 0443167251 round suppression core must be fitted at the load cable connector to reduce electromagnetic emissions.
7. An appropriately rated Cosel TAC series AC power filter in combination with a Fair Rite model 5977002701 torroid (placed on the supply end of the filter) must be fitted to the AC supply to any MOSFET drive system in order to reduce conducted emissions fed back into the supply network.

IGBT Switching Drives

8. An appropriately rated Cosel TAC series AC power filter in combination with a Fair Rite model 0443167251 round suppression core (placed on the supply end of the filter) must be fitted to the AC supply to any IGBT drive system in order to reduce conducted emissions fed back into the supply network.
9. A Fair Rite model 0443164151 round suppression core and model 5977003801 torroid must be fitted at the load cable connector to reduce electromagnetic emissions.

Fitting of AC Power Filters

10. It is possible for noise generated by the machine to "leak" onto the main AC power, and then get distributed to nearby equipment. If this equipment is sensitive, it may be

adversely affected by the noise. AC power filters can filter this noise and keep it from getting on the AC power signal. The above mentioned AC power filters should be mounted flat against the enclosure of the product using the mounting lugs provided on the filter. Paint should be removed from the enclosure where the filter is fitted to ensure good metal to metal contact. The filter should be mounted as close to the point where the AC power filter enters the enclosure as possible. Also, the AC power cable on the load end of the filter should be routed far from the AC power cable on the supply end of the filter and all other cables and circuitry to minimize RF coupling.

3.2.1 Ferrite Suppression Core Set-up

If PWM switching noise couples onto the feedback signals or onto the signal ground, then a ferrite suppression core can be used to attenuate the noise. Take the motor leads and wrap them around the suppression core as many times as reasonably possible, usually 2-5 times. Make sure to strip back the cable shield and only wrap the motor wires. There will be two wires for single phase (brushed) motors and 3 wires for three phase (brushless) motors. Wrap the motor wires together as a group around the suppression core and leave the motor case ground wire out of the loop. The suppression core should be located as near to the drive as possible. TDK ZCAT series snap-on filters are recommended for reducing radiated emissions on all I/O cables.

3.2.2 Inductive Filter Cards

Inductive filter cards are added in series with the motor and are used to increase the load inductance in order to meet the minimum load inductance requirement of the drive. They also serve to counteract the effects of line capacitance found in long cable runs and in high voltage systems. These filter cards also have the added benefit of reducing the amount of PWM noise that couples onto the signal lines.

3.2.3 Baseplate Isolation

The drive baseplate is not electrically isolated from the power rails. For 100V and higher FlexPro drive models, UL-compliant isolating thermal pads such as T-Global TG-A6200 or TG-A1250 shall be considered in the end product when the cooling interface is electrically connected to PE (AC powered systems) or chassis (battery powered systems) with potentials higher than nominal 48VDC to each power rail.

3.3 Grounding

In most servo systems all the case grounds should be connected to a single Protective Earth (PE) ground point in a "star" configuration. Grounding the case grounds at a central PE ground point through a single low resistance wire for each case ground reduces the chance for ground loops and helps to minimize high frequency voltage differentials between components. All ground wires must be of a heavy gauge and be as short as possible. The following should be securely grounded at the central PE grounding point:

- Motor chassis
- Controller chassis
- Power supply chassis
- PCB Interface chassis

FIGURE 3.1 System Grounding

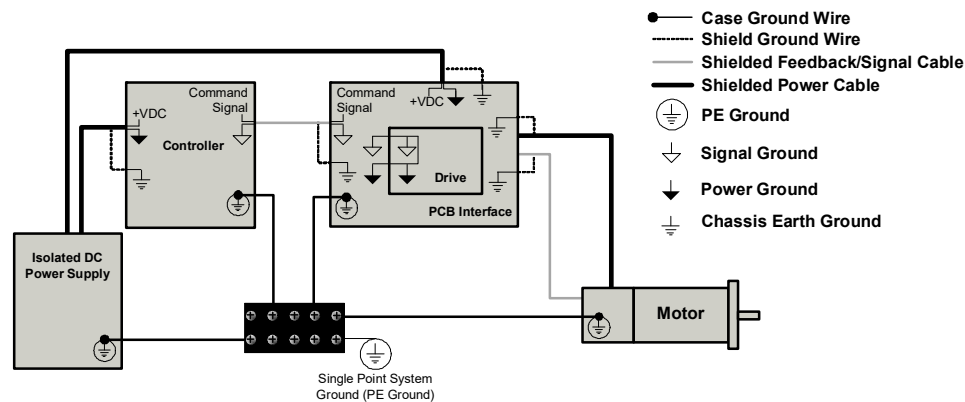

Ground cable shield wires at the mounting card or PCB interface side to a chassis earth ground point. The DC power ground and the input reference command signal ground are oftentimes at a different potential than chassis/PE ground. The signal ground of the controller must be connected to the signal ground of the FlexPro drive to avoid picking up noise due to the "floating" differential servo drive input. On all FlexPro drives, the DC power ground and the input command signal ground are referenced to each other internally. In systems using an isolated DC power supply, signal ground and/or power ground can be referenced to chassis ground. First decide if this is both appropriate and safe. If this is the case, they can be grounded at the central grounding point.



Grounding is important for safety. The grounding recommendations in this manual may not be appropriate for all applications and system machinery. It is the responsibility of the system designer to follow applicable regulations and guidelines as they apply to the specific servo system.

3.4 Wiring

Servo system wiring typically involves wiring a controller (digital or analog), a servo drive, a power supply, and a motor. Wiring these servo system components is fairly easy when a few simple rules are observed. As with any high efficiency PWM servo drive, the possibility of noise and interference coupling through the cabling and wires can be harmful to overall system performance. Noise in the form of interfering signals can be coupled:

- Capacitively (electrostatic coupling) onto signal wires in the circuit (the effect is more serious for high impedance points).
- Magnetically to closed loops in the signal circuit (independent of impedance levels).
- Electromagnetically to signal wires acting as small antennas for electromagnetic radiation.
- From one part of the circuit to other parts through voltage drops on ground lines.

Experience shows that the main source of noise is the high DV/DT (typically about 1V/nanosecond) of the drive's output power stage. This PWM output can couple back to the signal lines through the output and input wires. The best methods to reduce this effect are to move signal and motor leads apart, add shielding, and use differential inputs at the drive. For extreme cases, use of an inductive filter card or a noise suppression device is recommended. Unfortunately, low-frequency magnetic fields are not significantly reduced by metal enclosures. Typical sources are 50 or 60 Hz power transformers and low frequency current changes in the motor leads. Avoid large loop areas in signal, power-supply, and motor wires. Twisted pairs of wires are quite effective in reducing magnetic pick-up because the enclosed area is small, and the signals induced in successive twists cancel.

3.4.1 Wire Gauge

As the wire diameter decreases, the impedance increases. Higher impedance wire will broadcast more noise than lower impedance wire. Therefore, when selecting the wire gauge for the motor power wires, power supply wires, and ground wires, it is better to err on the side of larger diameter wire rather than too thin. This recommendation becomes more critical as the cable length increases.

3.4.2 Motor Wires

The motor power wires supply power from the drive to the motor. Use a twisted, shielded pair for the motor power cables to reduce the amount of noise coupling to sensitive components.

- For a single phase motor or voice coil, twist the two motor wires together as a group.
- For a three phase motor, twist all three motor wires together as a group.

Ground the motor power cable shield at one end only to the mounting card or PCB interface chassis ground. The motor power leads should be bundled and shielded in their own cable and

kept separate from feedback signal wires. For motor wire lengths over 3ft, motor wires should be individually shielded, not twisted.



Caution

DO NOT use wire shield to carry motor current or power!

3.4.3 Power Supply Wires

The PWM current spikes generated by the power output-stage are supplied by the internal power supply capacitors. In order to keep the current ripple on these capacitors to an acceptable level it is necessary to use heavy power supply leads and keep them as short as possible. Reduce the inductance of the power leads by twisting them. Ground the power supply cable shield at one end only to the mounting card or PCB interface chassis ground.

When multiple drives are installed in a single application, precaution regarding ground loops must be taken. Whenever there are two or more possible current paths to a ground connection, damage can occur or noise can be introduced in the system. The following rules apply to all multiple axis installations, regardless of the number of power supplies used:

1. Run separate power supply leads to each drive directly from the power supply filter capacitor.
2. Never "daisy-chain" any power or DC common connections. Use a "star"-connection instead.

3.4.4 Feedback Wires

Use of a twisted, shielded pair for the feedback wires is recommended. Ground the shield at one end only to the mounting card or PCB interface chassis ground. Route cables and/or wires to minimize their length and exposure to noise sources. The motor power wires are a major source of noise, and the motor feedback wires are susceptible to receiving noise. This is why it is never a good idea to route the motor power wires with the motor feedback wires, even if they are shielded. Although both of these cables originate at the drive and terminate at the motor, try to find separate paths that maintain distance between the two. A rule of thumb for the minimum distance between these wires is 10cm for every 10m of cable length.

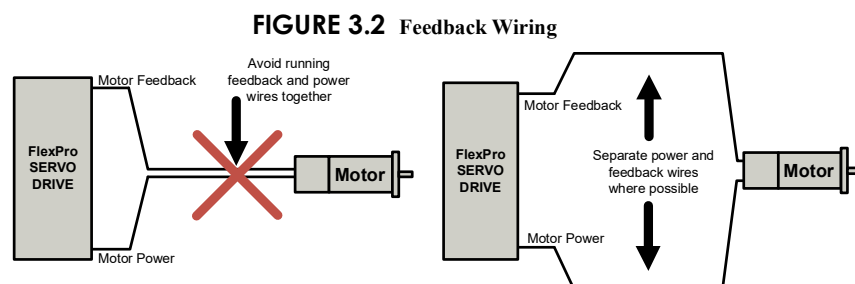

3.4.5 Input Reference Wires

Use of a twisted, shielded pair for the input reference wires is recommended. Connect the reference source "+" to "+REF IN", and the reference source "-" (or common) to "-REF IN". Connect the shield to the mounting card or PCB interface chassis ground. The servo drive's reference input circuit will attenuate the common mode voltage between signal source and drive power grounds.



Notice

In case of a single-ended reference signal, connect the command signal to "+ REF IN" and connect the command return and "- REF IN" to signal ground.

Long signal wires (10-15 feet and up) can also be a source of noise when driven from a typical OP-AMP output. Due to the inductance and capacitance of the wire the OP-AMP can oscillate. It is always recommended to set a fixed voltage at the controller and then check the signal at the drive with an oscilloscope to make sure that the signal is noise free.

3.5 Mounting

This section provides instructions and information on the different ways to mount a FlexPro servo drive to a PCB.

3.5.1 Development and Interface Board Assemblies

FlexPro servo drives are available as a development board assembly, or mounted to an interface board. The drive comes pre-soldered to the development or interface board, which features standard connectors to simplify the connections to the motor, power supply, feedback devices, and controller.

- The development board assembly is designed both for initial design and prototyping purposes.
- The interface board is designed for direct implementation into the final system design.

It is highly recommended to use a development board assembly for initial system proof-of-concept, as the proven capabilities will streamline and simplify the design and testing process.

TABLE 3.1 FlexPro Development and Interface Boards

Part Number*	Description
FDxxx-xx-EM	FExxx-xx-EM servo drive development board assembly; single axis, EtherCAT
FMxxx-xx-EM	FExxx-xx-EM servo drive mounted to interface board, single axis, EtherCAT
FDxxx-xx-CM	FExxx-xx-CM servo drive development board assembly; single axis, CANopen
FMxxx-xx-CM	FExxx-xx-CM servo drive mounted to interface board, single axis, CANopen
FDxxx-xx-RM	FExxx-xx-RM servo drive mounted to interface board, single axis, RS485/232
FMxxx-xx-RM	FExxx-xx-RM servo drive mounted to interface board, single axis, RS485/232
FDxxx-xx-IPM	FExxx-xx-IPM servo drive development board assembly; single axis, Ethernet/IP

*Note that the FM mounting cards for Ethernet/IP models are pending development.

FIGURE 3.3 FD Development Board Assemblies



FIGURE 3.4 FM Machine Embedded Assemblies

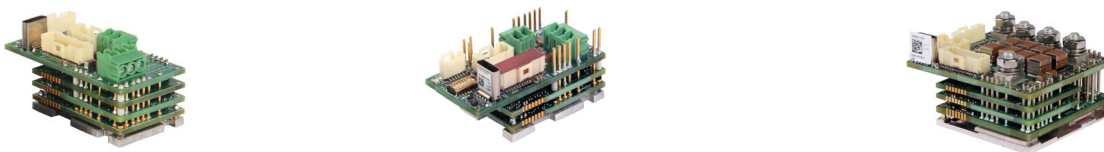

Pinouts, dimensions, and ordering information are obtainable on the product datasheets, available for download at www.a-m-c.com. The datasheet includes information on mating connectors and configuration options. In addition, users may design their own interface board to mate with a FlexPro servo drive. For more information on designing a compatible PCB interface card, see “PCB Design” on page 33 and “Interface Circuitry Examples” on page 35.

3.6 PCB Design

Before designing a PCB interface for FlexPro drives, it is highly recommended to use a development board assembly listed in “[Development and Interface Board Assemblies](#)” on [page 31](#) during the testing and prototyping stages of a system’s design. The proven capabilities of the development board will minimize troubleshooting and streamline the testing and integration process. For certain systems and applications, the development board can also be designed into the end-product.

For systems with spacing restrictions or other limiting factors that require a custom PCB interface, there are some key features that must be kept in mind to ensure proper operation.

3.6.1 Best Practice Design Recommendations and Requirements

Interface boards for FlexPro drives should be designed to the needs of the application and will vary in requirements, configurations, connectors, layout, and other factors; some design best practices covered in this manual can help mitigate problems or board spins.

Requirements

- The top and bottom planes must be 1oz copper to support the signal connector pins to the drive
- The I²C bus I/O expander is required for proper drive operation and must be included on the interface PCB with the appropriate connections. See “[I2C Data Signals](#)” on [page 49](#). Note the expander is required for proper drive operation unless the drive is loaded with firmware version 1-2021-4 or newer.
- The 5V or 3.3V supplies provided by the drive should not go out to the field for any reason with the exception of the 5V USER being used to power feedback devices only.

Best Practices

- Good thermal design helps keep the drive within safe temperature limits. Design for 100°C ambient temperature with a 10°C rise.
- Consider the thermals of attached power and motor cables based on peak current and length.
- Resistance in copper traces can account for significant power loss and heat generation for high power paths. Pull motor leads out as soon as possible and keep any high-power traces as short and direct as possible.
- Include ceramic or film capacitors for differential filtering.
- Air flow through the FlexPro architecture is expected for cooling, so consider air flow, heat transfer, and pressure drop of the application design.
- Keep the stackup symmetrical and centered.

3.6.2 Trace Width and Routing

The proper design and implementation of the PCB traces on an interface card is essential in maximizing drive efficiency and noise reduction.

- Keep high and low power signals separated - Although FlexPro servo drives have an internal connection between power and signal ground, the traces emitting from the Power

Connector carry high currents and voltages, while the traces emitting from the Signal Connector carry low currents and voltages. Refrain from routing power traces near signal traces, and never route them in parallel. If power traces and signal traces need to cross, they should do so at right angles.

- Keep high current traces short - Traces carrying high current, such as the DC Power traces and Motor Power traces, should be kept short and close together to minimize noise emissions. Also, keep DC Power traces separate from Motor Power traces where possible.
- Design for maximum values - Adjacent traces can carry a voltage potential equal to the maximum DC power supply value, and carry current of both the servo drive's peak and continuous current ratings. The trace width and copper plating thickness will need to take these maximum values into account.
- Use all terminal pins provided - For the Motor Phases, HV, and GND pins, FlexPro servo drives "share" a group of pins to spread the current between them. High current traces running to these pin groups should be inter-connected on the PCB board. Consult the drive's datasheet or the "Pinouts" section in "Products Covered" on page 5 for these pin groupings.

3.6.3 PCB Mounting Options

FlexPro servo drives must be directly soldered to a PCB interface board.

Signal Connector FlexPro drives use a narrow-pitch connector for I/O, feedback, and other low power signals. The mating connector compatible with FlexPro drive models is shown in the table below.

TABLE 3.2 Mating Connectors

Connector	Pins	Pitch	Manufacturer and Part Number
P1 Signal Connector	80	0.4mm	Panasonic: AXT380224

Terminal Pins It is required to solder the terminal pins on FlexPro drives to a PCB following the industry standard for Acceptability of Electronic Assemblies IPC-A-610D. Use solder with no-clean flux. FlexPro drives can be soldered by any of the following methods:

- wave soldering
- hand soldering
- selective wave soldering

To clean the PCB and drive after soldering, it is recommended to gently apply isopropyl alcohol or a cleaning agent with a soft-bristled brush. Use care not to apply downward pressure, but rather lightly brush the PCB and drive. Do not immerse the drive in a cleaning agent.

Nominal size for the FlexPro terminal pins is 0.040" diameter (+/-0.001"). Recommended hole size is 0.047" diameter, with a 0.065" square pad.

Screw Mounting For added stability and support, FlexPro drives can be mounted with screws to an external heatsink or other mounting plate using the mounting hole locations on the drive baseplate. Mounting to an external heatsink also provides improved thermal management behavior. See the specific drive's datasheet for exact screw locations and dimensions. CAD files are available for download from www.a-m-c.com.

3.6.4 Interface Circuitry Examples

The following sections show examples of how portions of an interface board could be designed to work with a FlexPro servo drive, and also contain general connection rules and instructions.



Figures are intended for reference only; review all circuitry for compatibility and compliance with the intended system application and design. Appropriate datasheets and/or installation manuals for external hardware (RJ-45 connectors, USB connector, feedback devices, etc.) should be carefully reviewed for specific requirements/circuitry before designing any interface PCB.

USB Interface FlexPro drives feature USB outputs that can be wired to a standard USB connection in either a single-axis configuration, or a multi-axis configuration through a USB hub controller. It is recommended to refer to www.usb.org and the datasheet/installation manual for the USB device(s) in use for the appropriate interface circuitry required for the specific system design and devices. [Figure 3.5](#) shows typical USB connection guidelines. See [Figure 3.24 on page 49](#) for additional information on I²C I/O expander signals.

FIGURE 3.5 Recommended USB Interface

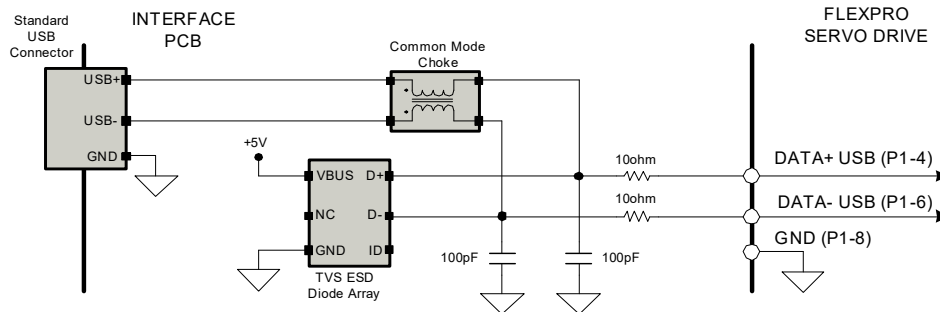

Logic Supply Input When using an external logic supply, logic power should be referenced to Power Ground. Figure 3.6 shows how to connect a logic power supply through a mounting card / interface PCB. On Fx100 FlexPro models, a separate logic supply is required. On Fx060 models, if no external logic supply is connected, the logic power will be generated internally from the main DC power; however, a separate external logic supply is the recommended configuration to decouple the power bus noise from the sensitive logic circuitry.

FIGURE 3.6 Recommended Auxiliary Logic Supply Input

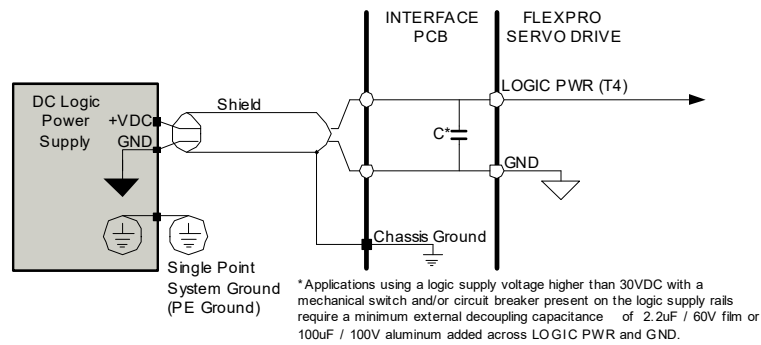

DC Power Input Figure 3.7 shows how a FlexPro servo drive connects to an isolated DC Power Supply through a mounting card/interface PCB. Notice that the power supply wires are shielded, and that the power supply case is grounded at the single point system ground (PE Ground). The cable shield should be grounded at the mounting card or PCB interface side to chassis ground. All HV Power terminal pins must be used.

FIGURE 3.7 Recommended DC Power Input

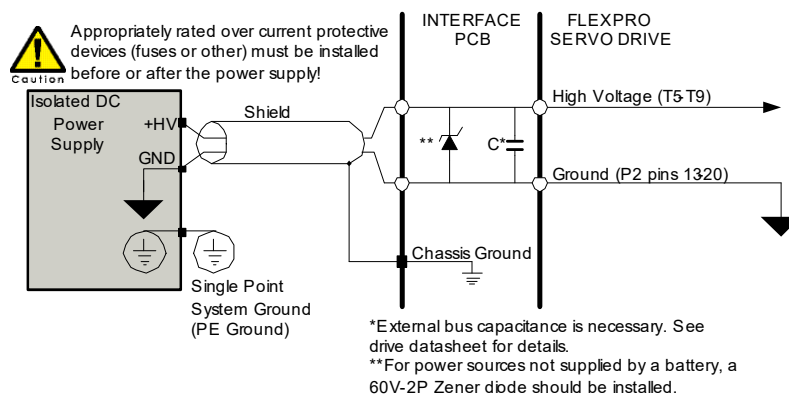

All HV supply input terminal pins and Power Ground terminal pins must be used.

To avoid drive damage, do not exceed the drive over voltage rating on the High Voltage input.

Use an appropriately rated Zener diode as shown in the above figure for power sources not supplied by a battery.

If the application has a power source going through a mechanical switch or has leads longer than 36 inches, a minimum 500µF / 100V external decoupling capacitance is required to be added across the HV and POWER GND to protect against over-voltage transients caused by bouncing in the switch.

Motor Power Output The figures below shows how a FlexPro servo drive connects to various motor types through a mounting card/interface PCB. Notice that the motor wires are shielded, and that the motor housing is grounded to the single point system ground (PE Ground). The cable shield should be grounded at the PCB interface side to chassis ground.

FIGURE 3.8 Recommended Motor Power Output

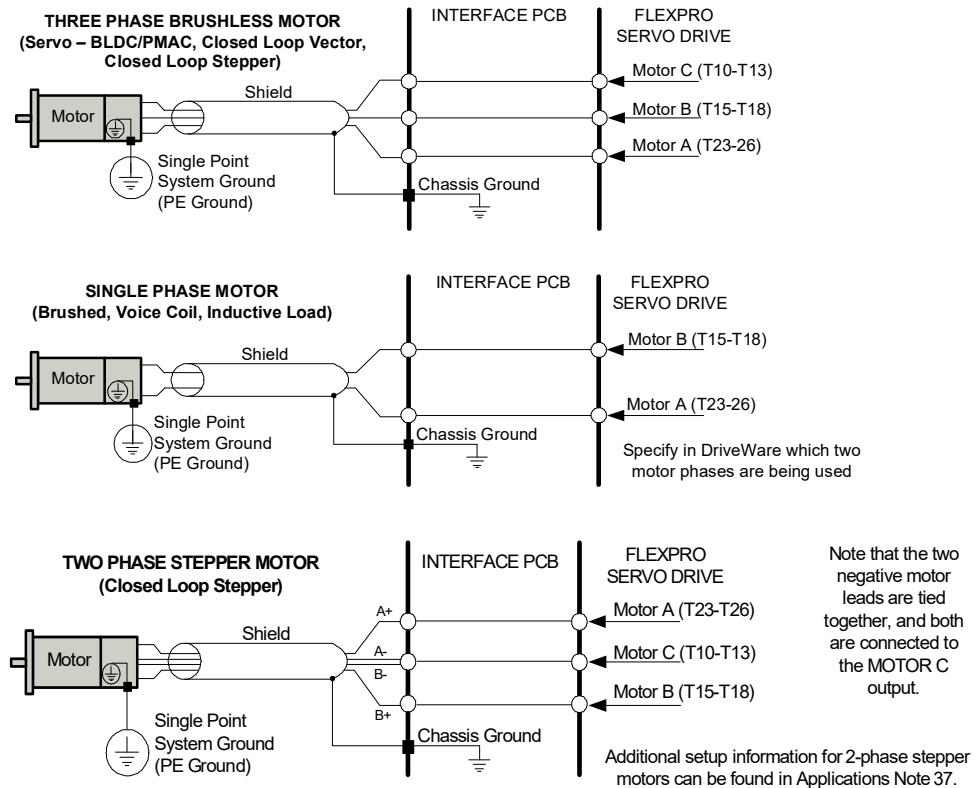

Caution

If using relays or other means to disconnect the motor leads, be sure the drive is disabled before reconnecting the motor leads to the drive. Connecting the motor leads to the drive while it is enabled can generate extremely high voltage spikes which will damage the drive.



Caution

For applications using stepper motors, the maximum motor speed will be limited (typically ~600 RPM max).



Caution

All available motor phase output terminal pins must be used.

Digital Inputs FlexPro drives provide 4 single-ended TTL level programmable digital inputs. [Figure 3.9](#) below is an example of how the mounting card/interface PCB should be designed for proper operation.

FIGURE 3.9 Recommended Standard Digital Inputs Interface

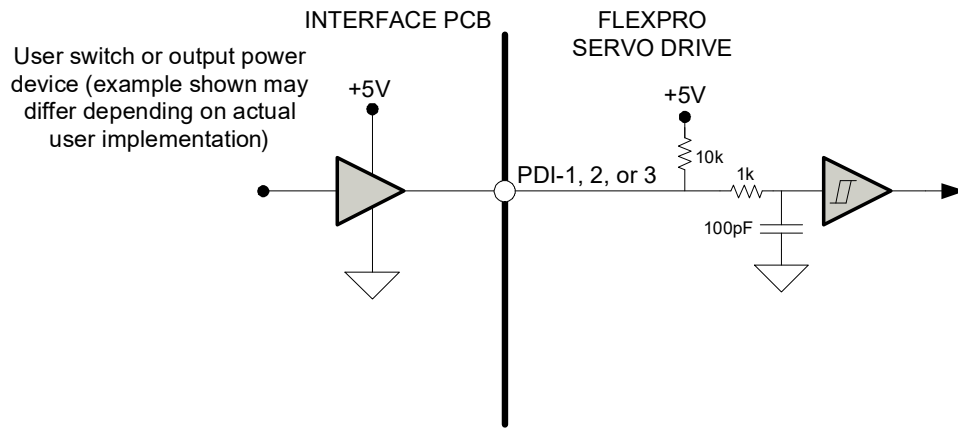

Digital Outputs FlexPro drives provide 3 single-ended programmable digital outputs. [Figure 3.10](#) is an example of how the mounting card/interface PCB should be designed for proper operation.

FIGURE 3.10 Recommended Digital Outputs Interface

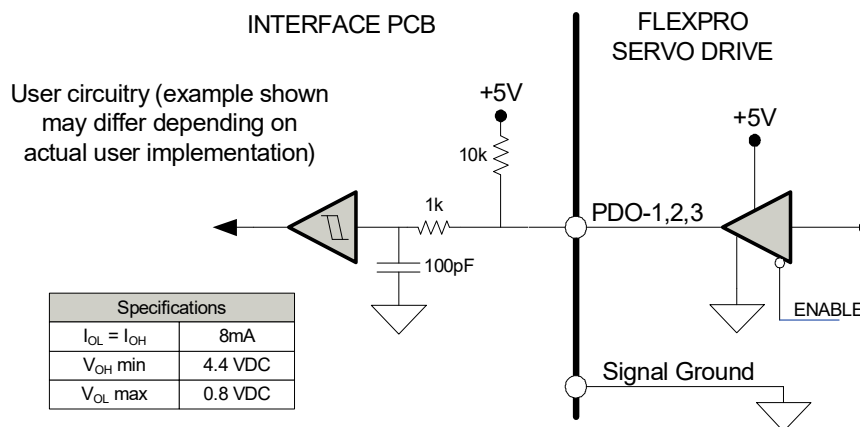

Analog Inputs FlexPro drives provide 1 programmable analog input. Figure 3.11 below is an example of how the mounting card/interface PCB should be designed for proper operation. For single-ended use, PAI-1- should be shorted to signal ground.

FIGURE 3.11 Recommended Analog Inputs Interface

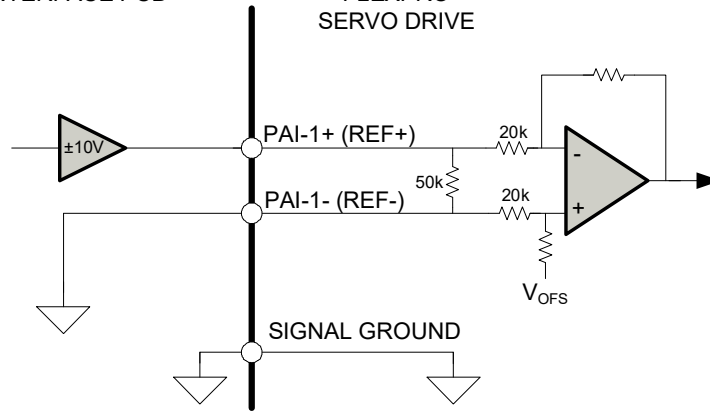

Hall Sensor Inputs FlexPro drives allow single-ended Hall Sensor inputs both for commutation and velocity feedback. Figure 3.12 shows the recommended circuitry.

FIGURE 3.12 Recommended Hall Sensor Interface

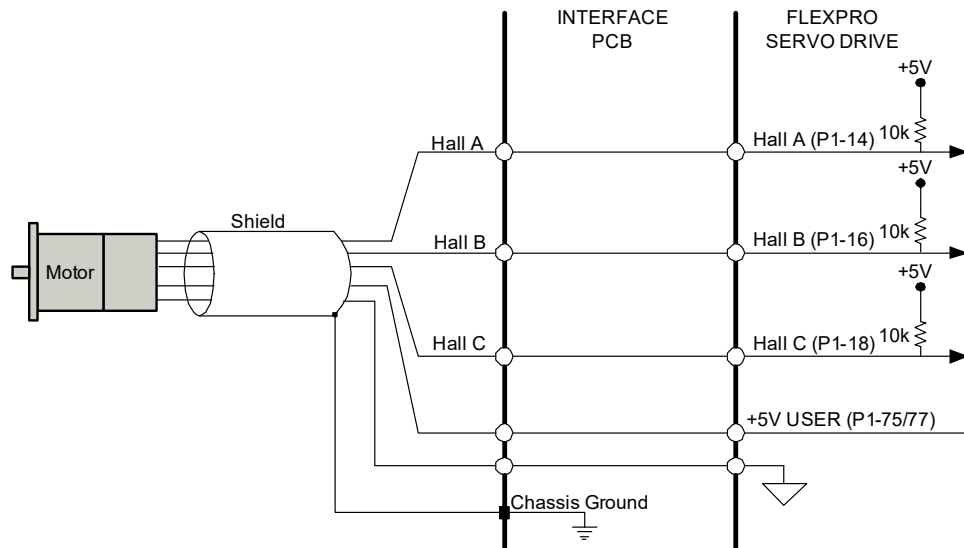

Encoder Inputs FlexPro drives support differential encoder inputs (Incremental or Absolute). If appropriate, the encoder can be powered by the +5V Supply Output pin provided on the FlexPro drive. Check the motor and encoder specifications for the encoder voltage and current requirements. Figure 3.13 shows the recommended circuitry.

FIGURE 3.13 Recommended Encoder Inputs Interface

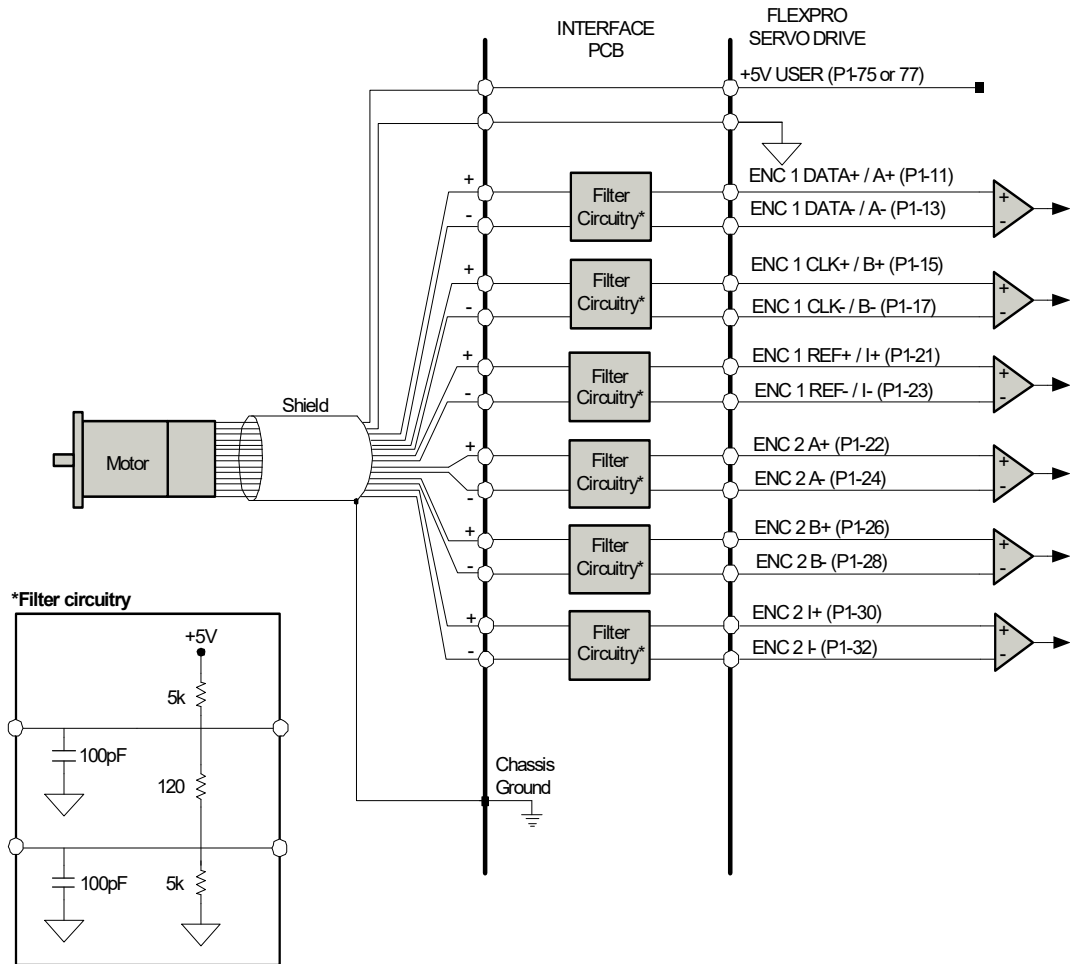

Auxiliary Encoder FlexPro drives accept a differential auxiliary encoder input that can be used for auxiliary position feedback, or as a command source when the drive is configured for Encoder Following. The auxiliary encoder signals are connected through the ENC 2 pins (P1-22/24, 26/28, and 30/32). Hardware settings and options for the auxiliary encoder can be entered and configured in the setup software. The drive will have to be operating in Position Mode in order to utilize the auxiliary encoder input. If appropriate, the encoder can be powered by the +5V USER pin provided on the FlexPro drive. Check the motor and encoder specifications for the encoder voltage and current requirements. Figure 3.13 shows the recommended circuitry.

STO (Safe Torque Off) Interface The FlexPro drive family features a dedicated +5VDC STO safety function designed to monitor an external 5V STO input from the user system and disable the motor output during an STO event. The STO circuit uses +5VDC sinking single-ended isolated inputs for STO functionality. Both STO1 and STO2 must be active (HIGH) to allow torque output at the drive motor outputs.

TABLE 3.3 STO Signal Behavior

STO 1	STO 2	Motor Outputs
Active (HIGH)	Active (HIGH)	Enabled
Active (HIGH)	Not Active (LOW)	Disabled
Not Active (LOW)	Active (HIGH)	Disabled
Not Active (LOW)	Not Active (LOW)	Disabled

FIGURE 3.14 STO Connections

See “Mounting” on page 31 and “PCB Design” on page 33 for connector and mating hardware information, and “Pinouts and Pin Layouts” on page 16 for pin numbering information. Functional Safety is designed to meet requirements of the following standards:

- EN ISO 13849-1 -- Category 4 / PL e
- EN IEC 61800-5-2 -- STO (SIL 3)
- EN 62061 -- SIL CL3
- IEC 61508 -- SIL 3

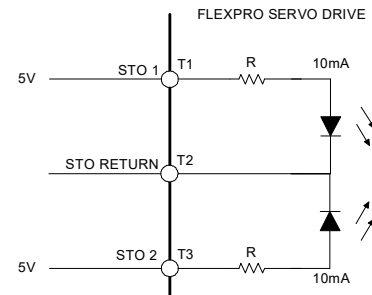

The monitoring circuit is required to be examined by an external logic element when STO is incorporated into a complete drive system in order for proper diagnostics to be fully implemented and utilized in the FMEA calculation (see “STO Operation Test” on page 42). The calculation of the safety relevant parameters are based on a proof test interval of one year and have shown that the requirements of up to SIL 3 are fulfilled. The safety relevant parameters are:

- Safe-Failure-Fraction: $SFF = 97\%$
- Probability of a dangerous failure per hour: $PFH = 1.3 \times 10^{-8} \text{ 1/h}$
- Average probability of a dangerous failure on demand (1 year): $PFD_{avg} = 1.7 \times 10^{-5}$



Note

The above assessment and safety values defined were assessed with the STO function incorporated into the FlexPro drive family. Product data for the FlexPro drive family can be found by visiting www.a-m-c.com.



Note

FlexPro drives provide the option of using 24VDC STO. Contact the factory for more details.

STO Disable

For applications that do not require Safe Torque Off functionality, disabling of the STO feature is required for proper drive operation. For FD060 (development board assembly) drive models that use a separate STO connector, a dedicated STO Disable Key plug is available for purchase and must be installed for applications where STO is not in use. Contact the factory for ordering information. Alternatively, and also for FE060 and FM060 drive models, STO may be disabled by wiring the designated pins together as given below in [Figure 3.15](#).

FIGURE 3.15 STO Disable Connections

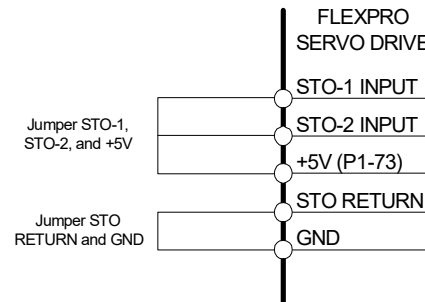

Note

Consult the datasheet of the drive in use to determine proper pin locations. It is recommended to jumper the signals together at the connection to the controller. The +5VDC signal may also come from an external +5VDC source.

STO Operation Test

The operation of the STO monitoring circuit (STO1 and STO2) must be verified at least once per month. The following procedure provides an example of a method to verify correct STO functionality. Note that it is the responsibility of the system operator to ensure all personal and machine safety requirements for the system are properly enforced during the proof test.

1. Power on the drive.
2. Verify the drive is in an Enabled state (by monitoring via a digital controller or network commands).
3. Remove the voltage signal from the STO1 input pin via a digital controller signal, network command.
4. Verify that the drive is in a Disabled state (via network commands or through the setup software).
5. Re-apply the voltage signal to the STO1 pin. Verify that the drive is once again in an Enabled state (by monitoring via a digital controller or network commands).
6. Repeat the above steps for the STO2 signal.



Note

End-product certification may require a different interval test schedule or test requirements. It is the responsibility of the end-user to determine the required test interval and requirements for certifications other than stated above.

EtherCAT Interface The LINK/ACT, STATUS, and ERROR signals serve as EtherCAT network indicators. LINK/ACT IN and LINK/ACT OUT are used to drive the corresponding LINK IN and LINK OUT LEDs on a typical RJ-45 connector, while the STATUS and ERROR signals are used to drive the EtherCAT Status and Error LEDs. Note that the ERROR LED signal comes from the I²C I/O expander. See [Figure 3.24 on page 49](#) for additional information on I²C I/O expander signals. It is recommended to refer to the datasheet/installation manual for the RJ-45 device(s) in use for the appropriate interface circuitry required for the specific user system design and devices. For a design using an RJ-45 connector with integrated magnetics and LEDs, [Figure 3.16](#) shows typical connection implementation. For a design using a discrete RJ-45 connector using external magnetics and LEDs, [Figure 3.17](#) shows typical connection implementation.

FIGURE 3.16 Recommended EtherCAT Communication Interface (internal magnetics/LEDs)

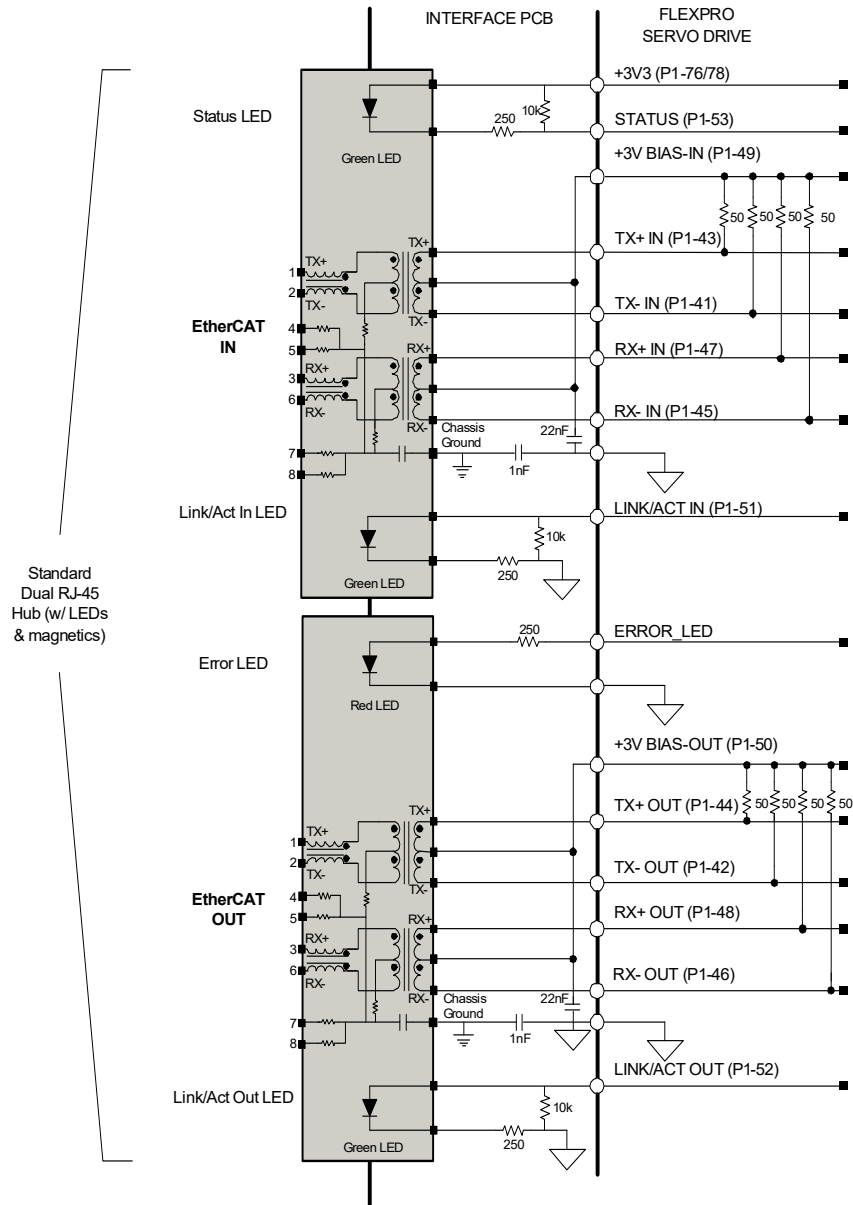
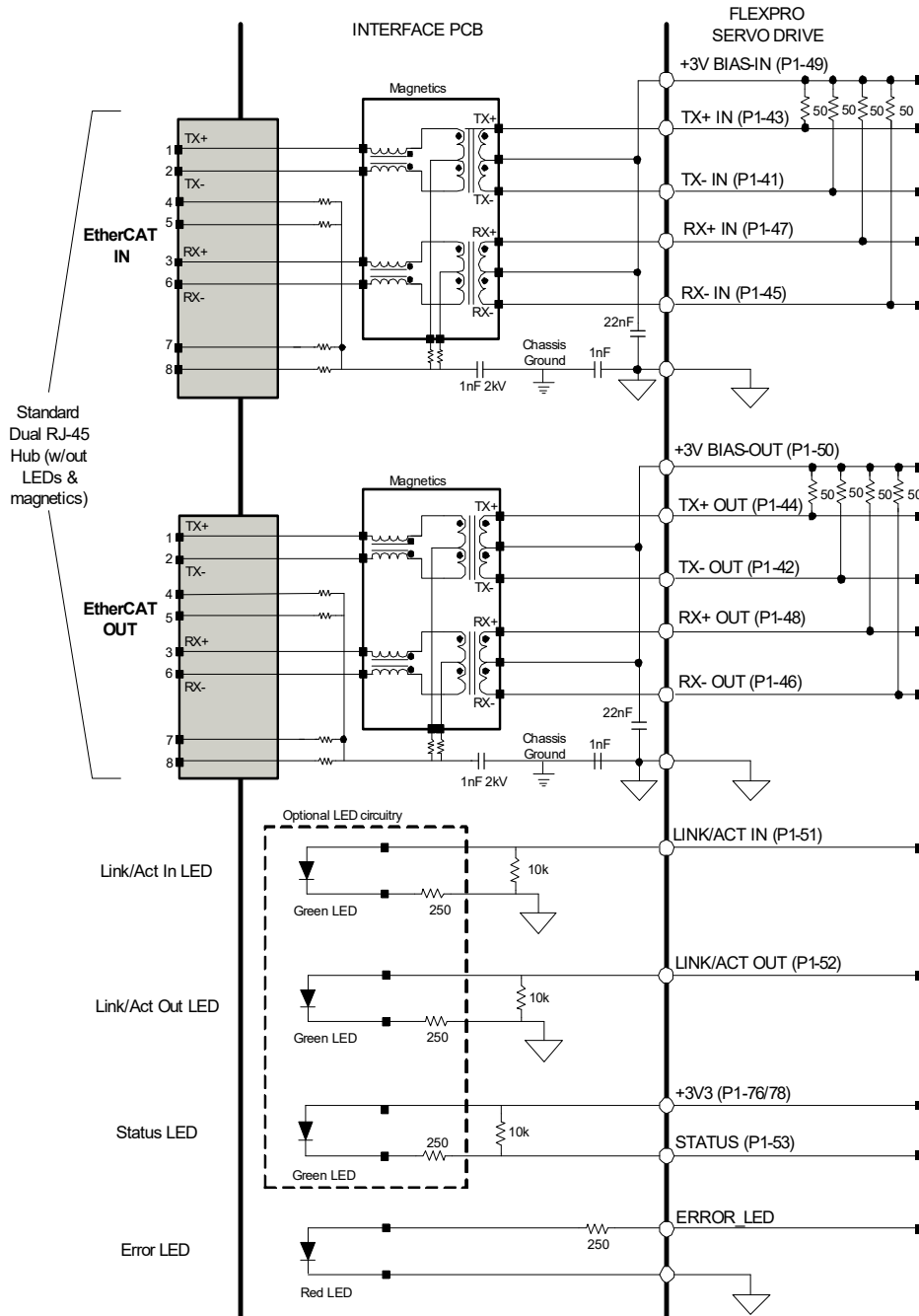

FIGURE 3.17 Recommended EtherCAT Communication Interface (external magnetics/LEDs)



Note

Pins P1-51, 52, and 53 are required connections as shown in the above diagrams, and are necessary for the drive to boot up correctly. The pull-up and pull-down circuitry must still be implemented even if the functions associated with these pins will not be used.

Magnetics are recommended on the input to drives on the interface PCB. If magnetics are not used, then the TX and RX lines should be cross-connected.

Multi-Axis EtherCAT Interface The recommended circuitry for a multi-axis EtherCAT interface is shown in Figure 3.18.

FIGURE 3.18 Recommended Multi-Axis EtherCAT Interface

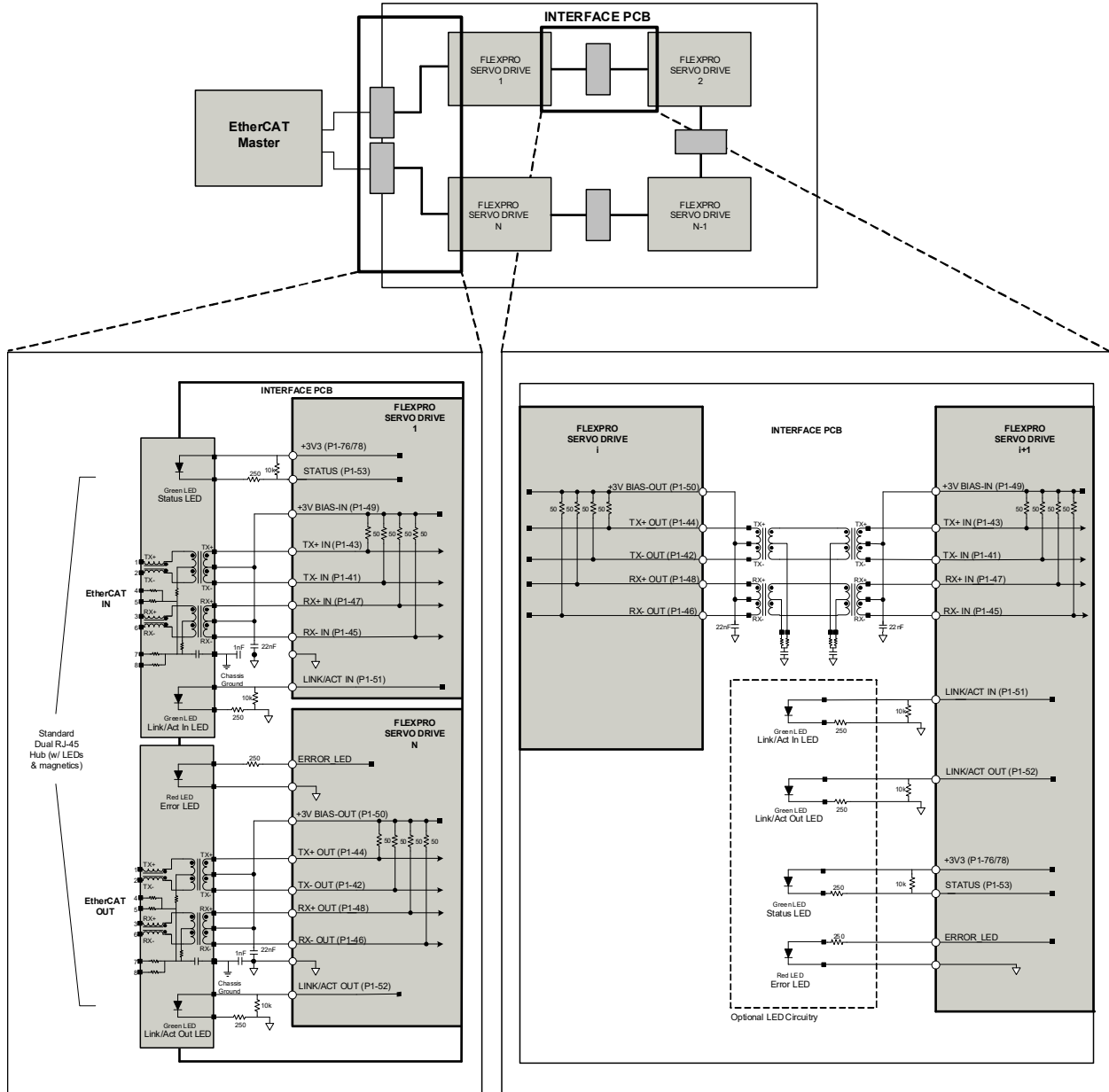

Note

Pins P1-51, 52, and 53 are required connections as shown in the above diagrams. If LEDs are not used, the pull-up and pull-down circuitry must still be in place.

Magnetics are recommended between drives on the interface card. If magnetics are not used, then the TX and RX lines should be cross-connected.

CANopen Interface A CAN transceiver and additional circuitry must be provided on the user's interface card. The recommended circuitry is shown in [Figure 3.19](#)

FIGURE 3.19 Recommended CANopen Interface

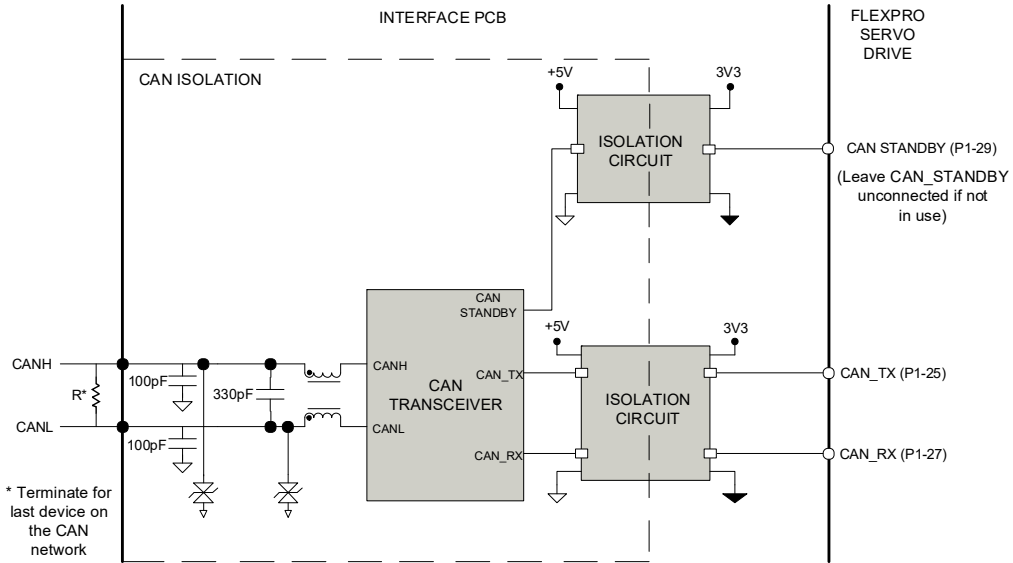

RS485/232 Interface Figure 3.20 is an example of how the RS485/232 connections could be realized when designing a mounting card or PCB interface for a FlexPro drive.

FIGURE 3.20 RS-485/232 Interface

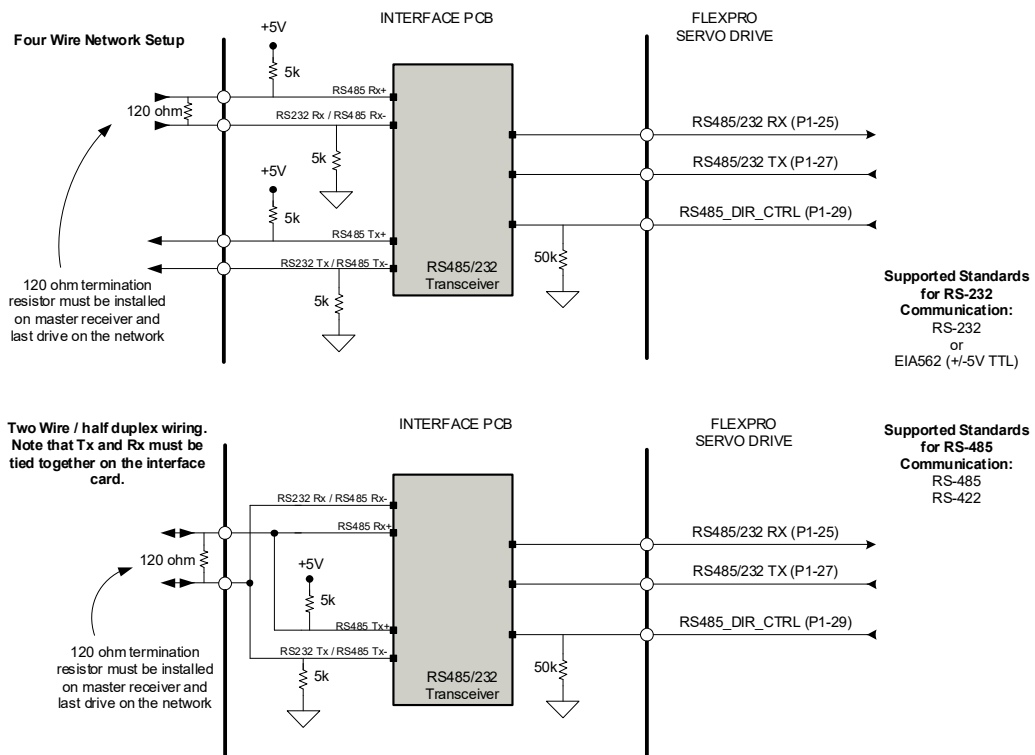

Ethernet/IP Interface The LINK/ACT IN, LINK/ACT OUT, MOD_STATUS and NET_STATUS signals serve as Ethernet/IP network indicators. MOD_STATUS is used to drive the corresponding MODULE STATUS LED on a typical RJ-45 connector, while NET_STATUS is used to drive the Ethernet/IP NETWORK STATUS LED. It is recommended to refer to the datasheet/installation manual for the RJ-45 device(s) in use for the appropriate interface circuitry required for the specific user system design and devices. For a design using an RJ-45 connector with integrated magnetics and LEDs, [Figure 3.16](#) shows typical connection implementation. For a design using a discrete RJ-45 connector using external magnetics and LEDs, [Figure 3.17](#) shows typical connection implementation.

FIGURE 3.21 Recommended Ethernet/IP Communication Interface (internal magnetics/LEDs)

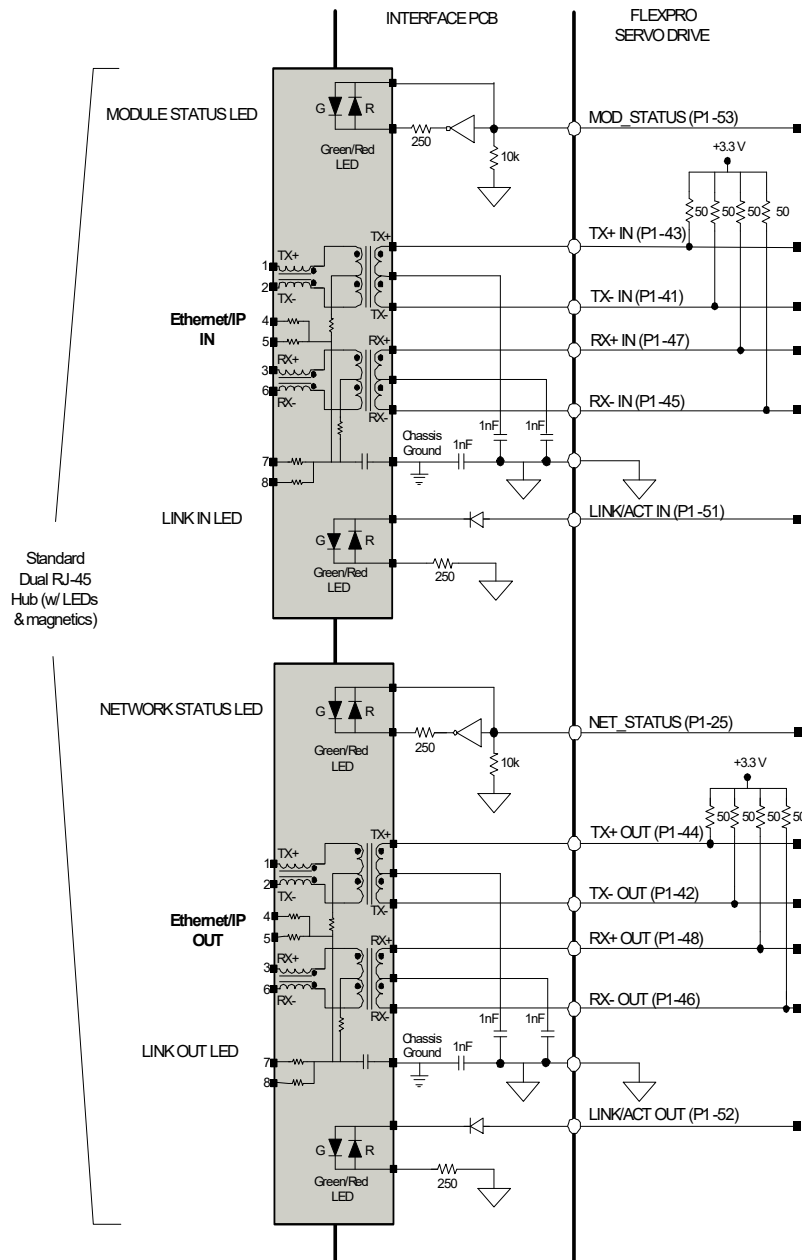
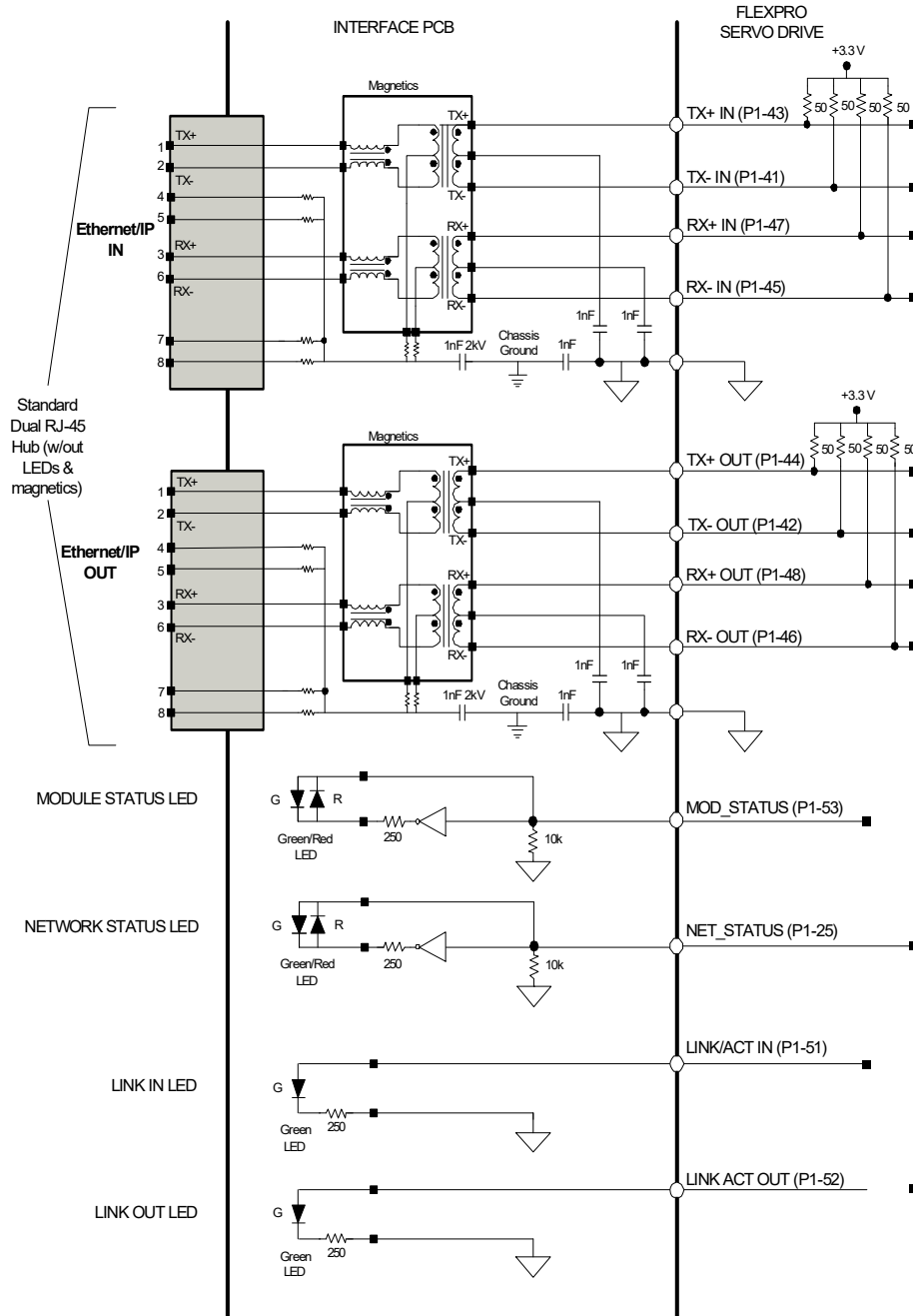

FIGURE 3.22 Recommended Ethernet/IP Communication Interface (external magnetics/LEDs)



Magnetics are recommended on the input to drives on the interface card. If magnetics are not used, then the TX and RX lines should be cross-connected.

Motor Thermistor Input An external motor thermistor or thermal switch should be connected between the motor thermistor input (P1-7) and ground as shown in [Figure 3.23](#).

FIGURE 3.23 Recommended Motor Thermistor Input

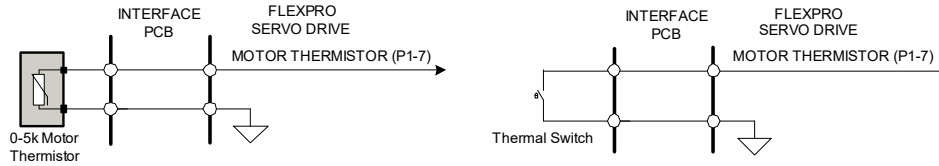

I²C Data Signals Certain drive functions are provided through an I²C bus I/O expander. The recommended circuitry and I/O expander are shown in the figure below. The corresponding circuitry for the drive functions are provided in the sections below. For more information on how to utilize and configure the I/O expander, consult the part datasheet. Note that for proper operation with FlexPro drives, the signal mappings must be identical to what is given in [Figure 3.24](#).

FIGURE 3.24 I²C Data Signals Recommended Circuitry

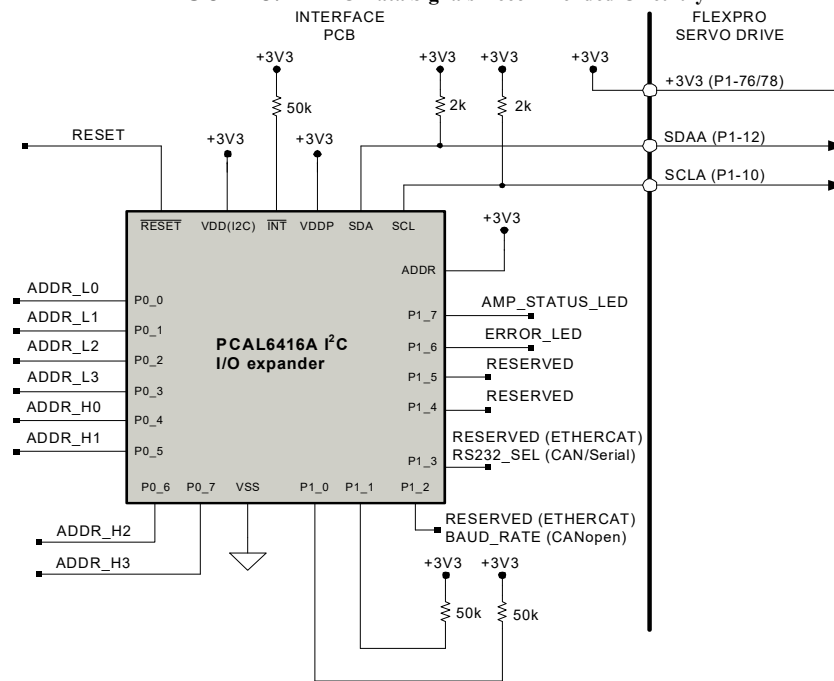

For CAN and Serial drives using firmware 1.2021.4 and newer, the I²C I/O expander is not required. In this case, the SCLA (P1-10) and SDAA (P1-12) pins on the drive should be tied to ground. Other features that are configured with the I/O expander (CAN address and baud rate, Status LED) will not be available in this scenario.

For EtherCAT drives, reserved pins P1-4/5 can be left open and P1-2/3 can be pulled to +3.3V with 100k resistors.

EtherCAT Error LED

The ERROR_LED (P1_6) from the I²C I/O expander can be used with the error LED function for EtherCAT network status. For recommended circuitry for the EtherCAT ERROR LED signal, see “EtherCAT Interface” on page 43.

Node Addressing

Node addressing via hardware is accomplished with the ADDR (P0_0...7) signals on the I²C I/O expander. These signals can be used with hardware hexadecimal switches to manually set the EtherCAT drive Station Alias (address), Ethernet/IP Network Address, or CANopen Node ID. Note that drives on an EtherCAT network will be given an address automatically based on proximity to the host. Setting the Station Alias manually is optional, and only required if a fixed address is required. The recommended circuitry for using hexadecimal switches with the ADDR signals is given below in Figure 3.25.

FIGURE 3.25 Recommended Addressing Switches Circuitry

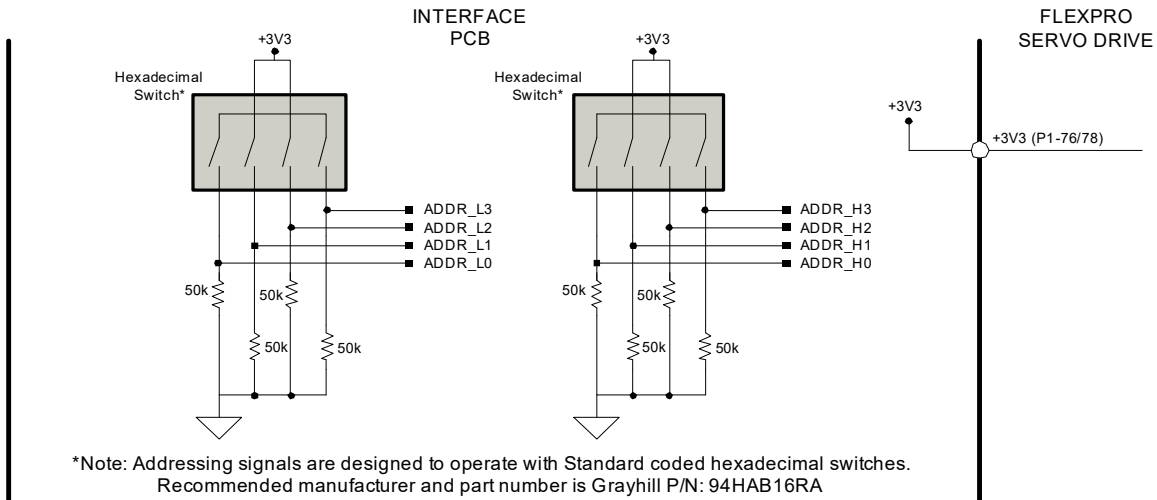

Default Baud Rate and RS485/232 Selection

Hardware DIP switch configuration for the baud rate and RS485/232 selection are accomplished using the circuitry as shown below.

FIGURE 3.26 Recommended Addressing Switches Circuitry

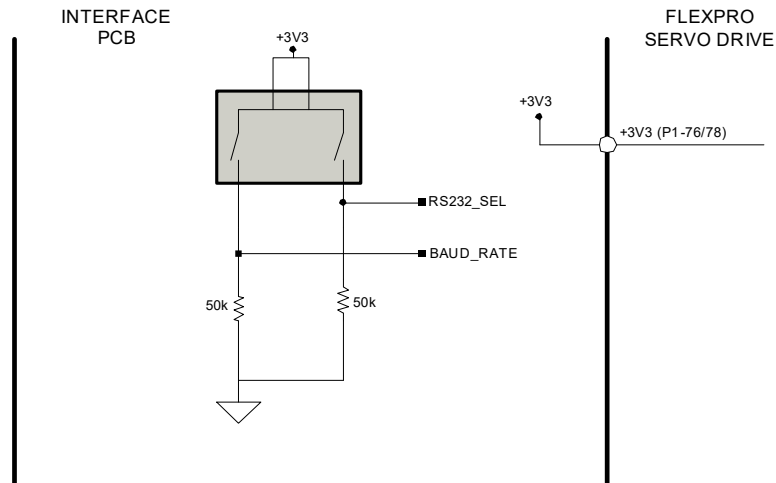

Drive Status LED

FlexPro drives feature a power bridge status LED output. The AMP_STATUS_LED (P1_7) signal from the I²C I/O expander is used to drive a single Bi-Directional LED as shown in Figure 3.27.

FIGURE 3.27 Recommended Drive Status LED Outputs

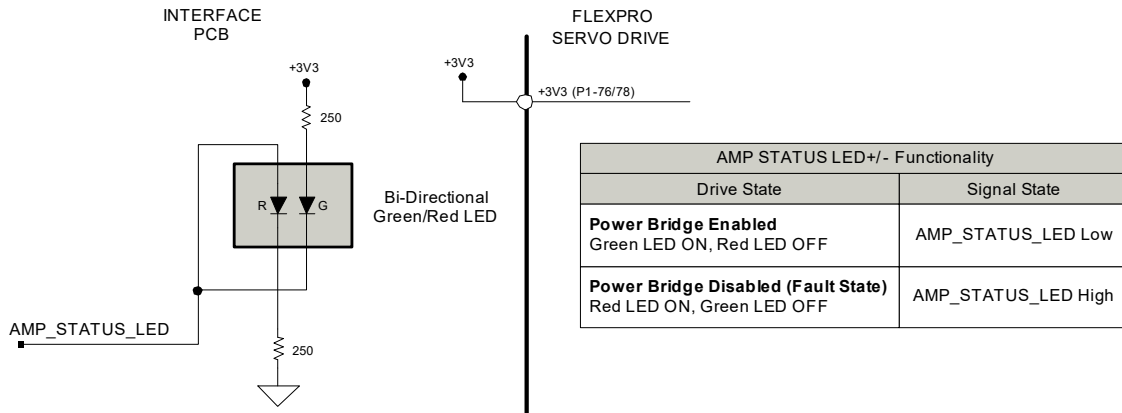

4 Operation and Features

This chapter will present a brief introduction on how to test and operate a FlexPro servo drive. Read through this entire section before attempting to test the drive or make any connections.

4.1 Features and Getting Started

To begin operation with your FlexPro drive, be sure to read and understand the previous chapters in this manual as well as the drive datasheet and the setup software manual. Ensure that all system specifications and requirements have been met, and become familiar with the capabilities and functions of the drive. Also, be aware of the “[Troubleshooting](#)” section at the end of this manual for solutions to basic operation issues.

4.1.1 Initial Setup and Configuration

Carefully follow the grounding and wiring instructions in the previous chapters to make sure your system is safely and properly set up. For initial testing purposes, it is not necessary to use a controller to provide a command input, or to have any load attached to the motor. The items required will be:

- FlexPro Servo Drive attached to PCB Interface; or FlexPro Development Board Assembly
- Motor
- DC Power Supply for supplying power to system
- Setup Software and Software Manual for detailed instructions on how to setup, tune and configure a FlexPro drive

The following steps outline the general procedure to follow when commissioning a FlexPro drive for the first time. The setup software manual contains more detailed information on each step.

1. **Check System Wiring:** Before beginning, check the wiring throughout the system to ensure proper connections and that all grounding and safety regulations have been followed appropriately for the system.



Caution

Do not apply power to the system until certain all wiring and grounding has been setup safely and properly!

When using a separate logic power supply, turn on the logic supply first before turning on the main power supply. When powering down, first remove the main power supply before turning off / removing the logic power.

2. **Apply Power:** Power must be applied to the drive before any communication or configuration can take place. Turn on the Logic supply first for drives using a separate logic supply, then turn on the main Power supply. Use a multimeter or voltmeter to check that the power supply level is within the specified range.
3. **Establish Connection:** Open the setup software on the PC. The FlexPro drive should be attached to a mounting card or PCB interface, and connected to the PC with a USB cable. Choose the "Connect to a drive" option when the software starts, and enter the appropriate communication settings in the options window that appears. See the setup software manual for more information on connecting to a drive. For connection issues, see ["Connection Problems" on page 62](#).
4. **Input Motor Data:** Once the software has connected to the drive, the motor and feedback information must be entered in the software. This information is required for the drive to be configured properly.
5. **Set User Units:** User Units allows the user to set the general units that will be used in the software. A variety of unit types are available, and the software also offers the option of using custom units.
6. **Configure Drive Limits and Events:** The setup software allows the user to manually configure system parameters and limits, and assign "actions" to specific events. The limits and their corresponding actions are used as both safety measures to avoid system damage, as well as parameter observation tools for drive configuration and troubleshooting.
7. **Tune the Current Loop:** Once the drive parameters are configured properly, the current loop must be tuned. This is the innermost loop and forms the basis of all motion. The current loop gains can be calculated based on the motor and application data entered in the previous two steps, or they can be set manually. The setup software manual contains instructions on current loop tuning.
8. **Commutate the Motor:** For Three Phase (Brushless) motors, commutation is necessary to maintain the optimal torque generation at any motor position. Typically this is accomplished by running the AutoCommutation routine in the software. Also see ["Ethernet/IP Communication LEDs Functionality" on page 55](#).

Once the drive has been commutated successfully, the drive is ready for further use, such as velocity or position loop tuning. Consult the setup software manual for the correct procedure.

4.1.2 Input/Output Pin Functions

FlexPro drives provide a number of various input and output pins for parameter observation and drive configuration options. Consult the drive datasheet to see which input/output pin functions are available for each drive.

Motor Thermistor Connect a 0-5 kohm thermistor between MOTOR THERMISTOR (P1-7) and GROUND. Thermistor behavior can be configured in the setup software.

Programmable Digital Inputs FlexPro drives provide four single-ended Programmable Digital Inputs (P1-31,33,35,37). These can be assigned to one or more functions in the setup software.

Programmable Digital Outputs FlexPro drives provide three single-ended General Purpose Programmable Digital Outputs (P1-34,36,38). These can be assigned to one or more functions in the setup software.

Programmable Limit Switch (PLS) Outputs

When a digital output is configured as a Programmable Limit Switch through the setup software, the maximum frequency of the output will correspond to the table below.

TABLE 4.1 Maximum Digital Output Frequency for PLS Outputs

5V I/O Control Modules	Maximum Frequency
	5 kHz (for 20 kHz switching frequency) ¹

1. Lower switching frequencies will result in lower output frequencies due to sampling on 5V I/O control modules.

Programmable Analog Input Pins P1-3 and P1-5 can be used as a differential Programmable Analog Input if they are not being used as an analog reference command input. A drive function can be assigned to the analog input in the setup software.

4.1.3 EtherCAT Communication LEDs Functionality

The LINK/ACT, STATUS, and ERROR LEDs on a typical RJ-45 connector provide EtherCAT network status. [Table 4.2](#) below describes typical LED functionality.

TABLE 4.2 EtherCAT Communication LEDs Function Protocol

LINK/ACT LED	
LED State	Description
Green - On	Valid Link - No Activity
Green - Flickering	Valid Link - Network Activity
Off	Invalid Link

STATUS LED	
LED State	Description
Green - On	The device is in the state OPERATIONAL
Green - Blinking (2.5Hz - 200ms on and 200ms off)	The device is in the state PRE-OPERATIONAL

STATUS LED	
LED State	Description
Green - Single Flash (200ms flash followed by 1000ms off)	The device is in state SAFE-OPERATIONAL
Green - Flickering (10Hz - 50ms on and 50ms off)	The device is booting and has not yet entered the INIT state or The device is in state BOOTSTRAP or Firmware download operation in progress
Off	The device is in state INIT

ERROR LED		
LED State	Description	Example
Red - On	A PDI Watchdog Timeout has occurred.	Application controller is not responding anymore.
Red - Blinking (2.5Hz - 200ms on and 200ms off)	General Configuration Error.	State change commanded by master is impossible due to register or object settings.
Red - Flickering (10Hz - 50ms on and 50ms off)	Bootling Error was detected. INIT state reached, but parameter "Change" in the AL status register is set to 0x01:change/error.	Checksum Error in Flash Memory.
Red - Single Flash (200ms flash followed by 1000ms off)	The slave device application has changed the EtherCAT state autonomously; Parameter "Change" in the AL status register is set to 0x01:change/error.	Synchronization error; device enters SAFE-OPERATIONAL automatically
Red - Double Flash (Two 200ms flashes separated by 200ms off, followed by 1000ms off)	An Application Watchdog Timeout has occurred.	Sync Manager Watchdog Timeout.

4.1.4 Ethernet/IP Communication LEDs Functionality

LED	Description	
MODULE STATUS	Off	No Power
	Green	Device Operational
	Flashing Green	Standby
	Flashing Red	Minor Fault
	Red	Major Fault
	Flashing Green/Red	Self-test
NETWORK STATUS	Off	Not powered, no IP address
	Flashing Green	No connection
	Green	Connected
	Flashing Red	Connection Timeout
	Red	Duplicate IP address
	Flashing Green/Red	Self-test

4.1.5 Commutation

Motor commutation is the process that maintains an optimal angle between the magnetic field created by the permanent magnets in the motor and the electromagnetic field created by the currents running through the motor windings. This process ensures optimal torque or force generation at any motor position. Single phase (brushed) motors accomplish this process with internal commutators built into the motor housing. Three phase (brushless) motors require a correctly configured drive to commutate properly, however. There are two ways to configure a FlexPro drive to commutate a three phase (brushless) motor in the setup software:

- AutoCommutation: Most applications can use the AutoCommutation routine in the setup software for configuring a drive to a specific motor. This routine will automatically detect the feedback devices attached to the motor and ask the user to verify them against the motor's data sheet.
- Manual Commutation: This process requires more time, and may not be as accurate as AutoCommutation. This method will have to be performed if:
 - The motor is mechanically restrained such that it is unable to rotate (AutoCommutation requires the motor to rotate 2 revolutions + 1 electrical cycle in both directions for a rotary motor, and 3 electrical cycles for a linear motor).
 - The motor or load has a significant amount of inertia.

For three phase (brushless) drives that use encoder feedback but no Hall Sensors, it is required to run the "Phase Detect" routine in the setup software before AutoCommutation. Phase Detect works by sending a small current signal to the motor, prompting the motor to vibrate slightly for a few seconds. The encoder feedback from this movement provides a starting position for the motor, allowing the drive to then be properly commutated.

See the setup software manual for more information on AutoCommutation, Manual Commutation, and Phase Detect.

FlexPro servo drives allow either sinusoidal or trapezoidal commutation.

Sinusoidal Commutation Sinusoidal commutation provides greater performance and efficiency than trapezoidal commutation. FlexPro drives can commutate sinusoidally when connected to a motor-mounted encoder. Sinusoidal Commutation works by supplying current to each of the three motor phases smoothly in a sinusoidal pattern. The flow of current through each phase is shifted by 120 degrees. The sum of the current flowing through all three phases adds up to zero. [Figure 4.1](#) shows one electrical cycle of the motor phase currents.

FIGURE 4.1 Sinusoidal Commutation Motor Phase Currents

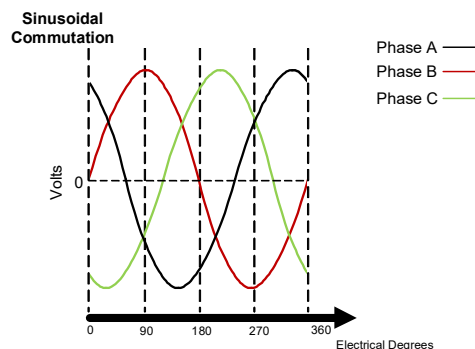

Trapezoidal Commutation Trapezoidal commutation is accomplished with the use of Hall Sensors on three phase (brushless) motors. FlexPro drives can commutate trapezoidally when used with properly spaced Hall Sensors. Unlike sinusoidal commutation, current flows through only two motor phases at a time with trapezoidal commutation. The Hall Sensors each generate a square wave with a certain phase difference (either 120- or 60-degrees) over one electrical cycle of the motor. This results in six distinct Hall states for each electrical cycle. Depending on the motor pole count, there may be more than one electrical cycle per motor

revolution. The number of electrical cycles in one motor revolution is equal to the number of motor poles divided by 2. For example:

- a 6-pole motor contains 3 electrical cycles per motor revolution
- a 4-pole motor contains 2 electrical cycles per motor revolution
- a 2-pole motor contains 1 electrical cycle per motor revolution

The drive powers two of the three motor phases with DC current during each specific Hall Sensor state as shown in [Figure 4.2](#).

FIGURE 4.2 Hall Sensor Commutation and Motor Phase Current for 120-Degree Phasing

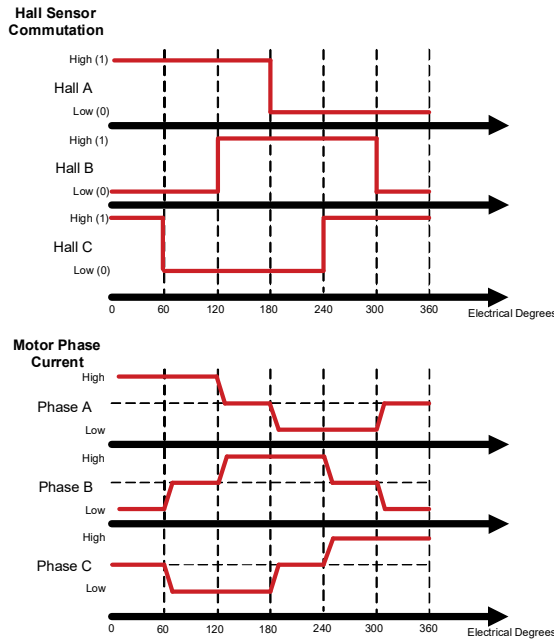

[Table 4.3](#) shows the default commutation states for 120-degree and 60-degree phasing. Depending on the specific setup, the sequences may change after running AutoCommutation.

TABLE 4.3 Drive Commutation Sequence Table

	60 Degree			120 Degree			Motor		
	Hall 1	Hall 2	Hall 3	Hall 1	Hall 2	Hall 3	Phase A	Phase B	Phase C
Valid	1	0	0	1	0	0	HIGH	-	LOW
	1	1	0	1	1	0	-	HIGH	LOW
	1	1	1	0	1	0	LOW	HIGH	-
	0	1	1	0	1	1	LOW	-	HIGH
	0	0	1	0	0	1	-	LOW	HIGH
	0	0	0	1	0	1	HIGH	LOW	-
Invalid	1	0	1	1	1	1	-	-	-
	0	1	0	0	0	0	-	-	-

4.1.6 Firmware

FlexPro drives are shipped with the latest version of firmware already stored in the drive. Periodic firmware updates are posted on *ADVANCED* Motion Controls’ website for download, at

www.a-m-c.com. See the setup software manual for information on how to check the drive's firmware version, and how to download new firmware into the drive when necessary.

A.1 Specifications Tables

TABLE A.1 Power Specifications - Micro Sized Drives

Description	Units	Fxx060-1	Fxx060-5	Fxx060-10	Fxx060-25	Fxx060-60C	Fxx100-25
Nominal DC Supply Input Range	VDC	12 - 48	12 - 48	12 - 48	12 - 48	12 - 48	18 - 90
DC Supply Voltage Range	VDC	10 - 55	10 - 55	10 - 55	10 - 55	10 - 55	18 - 90
DC Bus Over Voltage Limit	VDC	58	58	58	58	58	95
DC Bus Under Voltage Limit	VDC	8	8	8	8	8	15
Logic Supply Voltage	VDC	10 - 55	10 - 55	10 - 55	10 - 55	10 - 55	10 - 55
Maximum Peak Output Current	A (A_{rms})	2 (1.4)	10 (7.1)	20 (14.1)	50 (35.3)	-	50 (35.3)
Maximum Continuous Output Current	A (A_{rms})	1 (1)	5 (5)	10 (10)	25 (25)	60 (60)	25 (25)
Maximum Continuous Output Power	W	54	272	545	1361	3267	2228
Maximum Power Dissipation at Rated Power	W	1	3	6	14	33	23
Minimum Load Inductance ¹	μ H	150	150	150	150	150	150
Switching Frequency	kHz	20	20	20	20	20	20
Maximum Output PWM Duty Cycle	%	83	83	83	83	83	83

TABLE A.2 Power Specifications - Mini Sized Drives

Description	Units	Fxx100-50	Fxx060-100
Nominal DC Supply Input Range	VDC	20 - 90	10 - 55
DC Supply Voltage Range	VDC	20 - 90	10 - 55
DC Bus Over Voltage Limit	VDC	100	58
DC Bus Under Voltage Limit	VDC	15	9
Logic Supply Voltage	VDC	10 - 55	10 - 55
Maximum Peak Output Current	A (A_{rms})	100 (70.7)	200 (141.4)
Maximum Continuous Output Current	A (A_{rms})	50 (50)	100 (100)
Maximum Continuous Output Power	W	4455	5445
Maximum Power Dissipation at Rated Power	W	45	55
Minimum Load Inductance ¹	μ H	250	250
Switching Frequency	kHz	20	20
Maximum Output PWM Duty Cycle	%	83	83

1. Lower inductance is acceptable for bus voltages well below minimum. Use external inductance to meet requirements.

TABLE A.3 Control Specifications

Description	Fxxxx-xx-EM	Fxxxx-xx-IPM	Fxxx-xx-CM	Fxxx-xx-RM
Network Communication	EtherCAT (USB for configuration)	Ethernet/IP (USB for configuration)	CANopen (USB for configuration)	RS485/232 (USB for configuration)
Command Sources	±10V Analog, Over the Network, Encoder Following, Sequencing, Indexing, Jogging, Step & Direction			
Commutation Methods	Sinusoidal, Trapezoidal			
Control Modes	Profile Modes, Cyclic Synchronous Modes, Current, Velocity, Position	Profile Modes, Current, Velocity, Position	Profile Modes, Cyclic Synchronous Modes, Current, Velocity, Position, Interpolated Position Mode (PVT)	Current, Velocity, Position
Motors Supported	Three Phase (Brushless Servo), Single Phase (Brushed Servo, Voice Coil, Inductive Load), Stepper (2- or 3-phased Closed Loop), AC induction (Closed Loop Vector)			
Hardware Protection	40+ Configurable Functions, Over Current, Over Temperature (Drive & Motor), Over Voltage, Short Circuit (Phase-Phase & Phase-Ground), Under Voltage			
Programmable Digital I/O	4 Inputs, 3 Outputs			
Programmable Analog I/O	1 Input			
Feedback Supported	Hall Sensors, Incremental Encoder, Aux. Incremental Encoder, Absolute Encoder (BiSS C-Mode, EnDat2.2), Tachometer (±10 VDC)		Hall Sensors, Incremental Encoder, Aux. Incremental Encoder, Absolute Encoder (BiSS C-Mode, EnDat 2.2, Tamagawa/Nikon, SSI), Tachometer (±10 VDC)	

TABLE A.4 Standard Environment Specifications

Parameter	Description
Ambient Operating Temperature Range	0 - 65 °C (32 - 149 °F)
Storage Temperature Range	-40 - 85 °C (-40 - 185 °F)
Relative Humidity	0-95%, non-condensing

TABLE A.5 Extended Environment Specifications

Parameter	Description
Ambient Operating Temperature Range	-40 - 95 °C (-40 - 203 °F)
Storage Temperature Range	-50 - 100 °C (-58 - 212 °F)
Relative Humidity	0-95%, non-condensing
Thermal Shock	-40 - 95 °C (-40 - 203 °F) within 3 min
Vibration	25 Grms for 5 minutes in 3 axes
Altitude	-400m to +25000m
Contaminants	Pollution Degree 2

This section discusses how to ensure optimum performance and, if necessary, get assistance from the factory.

B.1 Fault Conditions and Symptoms

An inoperative drive is typically an indication of a disabling fault condition. The fault condition can either be caused by a system parameter in excess of software or hardware limits, or by an event that has been user-configured to disable the drive upon occurrence.

To determine whether the drive is in a fault state, use the Drive Status function in the setup software to view active and history event items and drive fault conditions. See the setup software manual for more information on reading the Drive Status window. Some common fault conditions caused by hardware issues are listed below.

Over-Temperature Verify that the baseplate temperature is less than the maximum allowable baseplate temperature value. The drive remains disabled until the temperature at the drive baseplate falls below this threshold.

Over-Voltage Shutdown

1. Check the DC power supply voltage for a value above the drive over-voltage shutdown limit. If the DC bus voltage is above this limit, check the AC power line connected to the DC power supply for proper value.
2. Check the regenerative energy absorbed during deceleration. This is done by monitoring the DC bus voltage with a voltmeter or oscilloscope. If the DC bus voltage increases above the drive over-voltage shutdown limit during deceleration or regeneration, a shunt regulator may be necessary. See [“Power Supply Specifications” on page 20](#) for more information.

Under-Voltage Shutdown Verify power supply voltage for minimum conditions per specifications. Also note that the drive will pull the power supply voltage down if the power supply cannot provide the required current for the drive. This could occur when high current is demanded and the power supply is pulled below the minimum operating voltage required by the drive.

Short Circuit Fault

1. Check each motor lead for shorts with respect to motor housing, power ground, and also phase-to-phase. If the motor is shorted it will not rotate freely when no power is applied while it is uncoupled from the load.
2. Disconnect the motor leads to see if the drive will enable without the motor connected.
3. Measure motor armature resistance between motor leads with the drive disconnected.

Invalid Hall Sensor State See the "Commutation Sequence" table in ["Incremental Encoder Feedback" on page 12](#) for valid commutation states. If the drive is disabled check the following:

1. Check the voltage levels for all the Hall sensor inputs.
2. Make sure all Hall Sensor lines are connected properly.

B.1.1 Software Limits

Because the setup software allows user configuration of many system parameters such as current, velocity, and position limits, as well as an associated "event action" for the software to take when the system reaches this limit, it is possible for a drive to appear to be inoperative when in actuality it is simply in an assigned disable state.

For example, the motor velocity can be limited by giving a value to the Motor Over Speed selection in the software. An "event action", such as "Disable the Power Bridge", can also be assigned for the software to take if the motor reaches this speed. If the motor does happen to reach this velocity limit, the software will automatically cut power to the drive's output in this particular case, and the drive will be disabled. In the Drive Status window, "Motor Over Speed" will be shown as a "history" event, and "Commanded Disable" will be shown as an "Action" event.

Depending on each specific system and application, there are many different options available for assigning system limits and associated actions. See the setup software manual for more information.

B.1.2 Connection Problems

Connection problems are oftentimes caused by incorrect communication settings in the setup software. The default factory setting for FlexPro drives is a Drive Address of 63 and 115200 Baud Rate. When connecting to the drive with the setup software for the first time, the default factory settings will have to be used along with the appropriate serial port being used with the PC. Once the connection has been established, the Drive Address and Baud Rate may be changed. Check all communications settings to be sure that the Drive Address, Baud Rate, and serial port are correct. If unable to determine the appropriate settings, the Auto Detect routine will automatically scan for serial port and Baud Rate settings.

Faulty connection cables are also a possible cause of connection problems. Check all cables for any shorts or intermittent connections.

B.1.3 Overload

Verify that the minimum inductance requirement is met. If the inductance is too low it could appear like a short circuit to the drive and thus it might cause the short circuit fault to trip. Excessive heating of the drive and motor is also characteristic of the minimum inductance requirement not being met. See drive data sheets for minimum inductance requirements.

B.1.4 Current Limiting

All drives incorporate a “fold-back” circuit for protection against over-current. This “fold-back” circuit uses an approximate “ I^2t ” algorithm to protect the drive. All drives can run at peak current for a maximum of 2 second (each direction). Currents below this peak current but above the continuous current can be sustained for a longer time period, and the drive will automatically fold back at an approximate rate of “ I^2t ” to the continuous current limit within a time frame of less than 10 seconds. An over-current condition will not cause the drive to become disabled unless configured to do so in the setup software.

FIGURE B.1 Peak Current Fold-Back

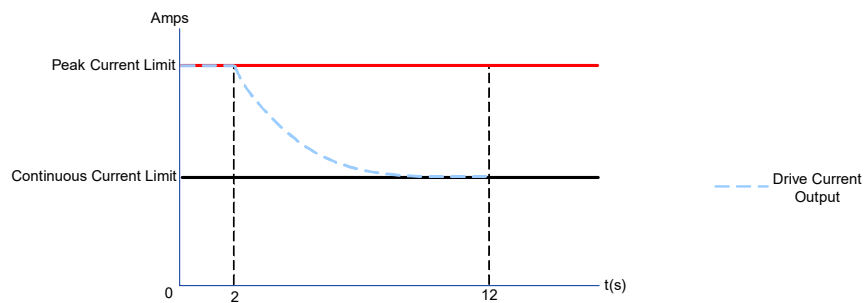

B.1.5 Motor Problems

A motor run-away condition is when the motor spins rapidly with no control from the command input. The most likely cause of this error comes from having the feedback element connected for positive feedback. This can be solved by changing the order that the feedback element lines are connected to the drive, or by using the setup software to reverse the internal velocity feedback polarity setting.

Another common motor issue is when the motor spins faster in one direction than in the other. This is typically caused by improper motor commutation or poor loop tuning. Follow the steps in the setup software manual to properly commutate and tune the motor.

B.1.6 Causes of Erratic Operation

- Improper grounding (i.e., drive signal ground is not connected to source signal ground).
- Noisy command signal. Check for system ground loops.
- Mechanical backlash, dead-band, slippage, etc.
- Noisy inhibit input line.
- Excessive voltage spikes on bus.

B.2 Technical Support

For help from the manufacturer regarding drive set-up or operating problems, please gather the following information.

B.2.1 Drive Model Information

- DC bus voltage and range.
- Motor type, including inductance, torque constant, and winding resistance.
- Length and make-up of all wiring and cables.
- If brushless, include Hall sensor information.
- Type of controller, plus full description of feed back devices.
- Description of problem: instability, run-away, noise, over/under shoot, or other description.
- Complete part number and serial number of the product. Original purchase order is helpful, but not necessary.

B.2.2 Product Label Description

The following is a typical example of a product label as it is found on the drive:

FIGURE B.2 Product Label

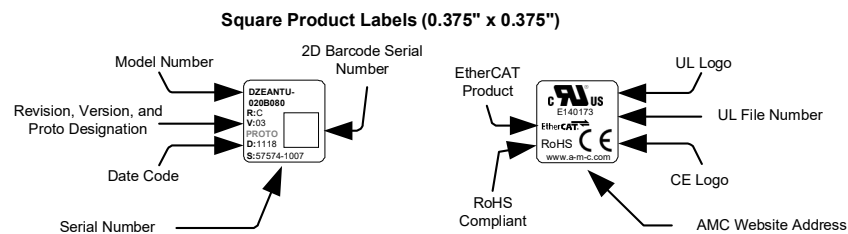

1. **Model Number:** This is the main product identifier. The model number can have a suffix designating a change from the base model.
2. **Revision Letter:** Product revision level letter ('A' is the earliest release from any model).
3. **Version:** The version number is used to track minor product upgrades with the same model number and revision letter ('01' is the earliest release of any revision).
4. **Proto Designation:** When included, indicates that the model is a prototype unit and model number will also begin with an 'X' designator.
5. **Serial Number:** The serial number consists of a 5-digit lot number followed by a 4-digit sequence number. Each product is assigned a unique serial number to track product life cycle history.
6. **Date Code:** The date code is a 4-digit number signifying the year and week of manufacture. The first two digits designate the year and the second two digits designate the week (e.g. the drive label shown would have been built in the year 2011 during the 18th week).
7. **General Information:** Displays applicable agency approvals, UL file reference number, compliance approvals, and EtherCAT capability. More complete product information is available by following the listed website.

B.2.3 Warranty Returns and Factory Help

Seller warrants that all items will be delivered free from defects in material and workmanship and in conformance with contractual requirements. The Seller makes no other warranties, express or implied and specifically NO WARRANTY OF MERCHANTABILITY OR FITNESS FOR A PARTICULAR PURPOSE.

The Seller's exclusive liability for breach of warranty shall be limited to repairing or replacing at the Seller's option items returned to Seller's plant at Buyer's expense within one year of the date of delivery. The Seller's liability on any claim of any kind, including negligence, for loss or damage arising out of, connected with or resulting from this order, or from the performance or breach thereof or from the manufacture, sale, delivery, resale, repair or use of any item or services covered by or furnished under this order shall in no case exceed the price allocable to the item or service or part thereof which gives rise to the claim and in the event Seller fails to manufacture or deliver items other than standard products that appear in Seller's catalog. Seller's exclusive liability and Buyer's exclusive remedy shall be release of the Buyer from the obligation to pay the purchase price. IN NO EVENT SHALL THE SELLER BE LIABLE FOR SPECIAL OR CONSEQUENTIAL DAMAGES.

Buyer will take all appropriate measures to advise users and operators of the products delivered hereunder of all potential dangers to persons or property, which may be occasioned by such use. Buyer will indemnify and hold Seller harmless from all claims of any kind for injuries to persons and property arising from use of the products delivered hereunder. Buyer will, at its sole cost, carry liability insurance adequate to protect Buyer and Seller against such claims.

All returns (warranty or non-warranty) require that you first obtain a Return Material Authorization (RMA) number from the factory.

Request an RMA number by:

telephone	(805) 389-1935
fax	(805) 389-1165
web	https://www.a-m-c.com/rma-returns-and-repairs/

Numerics

10 V Analog Input 15

A

Agency Compliances ii
 Ambient Temperature Range 22
 Analog Inputs 39
 Attention Symbols iii
 Auto Detect 62
 AutoCommutation 56
 Auxiliary Encoder 15

B

Baud Rate 62

C

Capacitive Interference 28
 Central Point Grounding 27
 Command Sources 15
 10V Analog 15
 Encoder Following 15
 Indexing and Sequencing 15
 Jogging 15
 Over the Network 15
 Communication Protocol 7
 Communication Settings 62
 Communication Wires 30
 Commutation 53, 55–57
 AutoCommutation 56
 Manual Commutation 56
 Sinusoidal 56
 Trapezoidal 56
 Commutation Sequence Table 57
 Company Website ii
 Connection Problems 62
 Control Modes 9–10
 Current (Torque) 9
 Cyclic Synch Modes 10
 Position 9
 Profile Modes 9
 Velocity 9
 Control Specifications 6
 Current (Torque) Mode 9
 Current Limiting 63
 Cyclic Synch. Current Mode 10
 Cyclic Synch. Position Mode 10
 Cyclic Synch. Velocity Mode 10

D

DC Bus Over Voltage Limit 5, 59
 DC Bus Under Voltage Limit 5, 59
 DC Power Input 36
 DC Supply Voltage Range 5, 59
 Development Board 31
 Differential Inputs 28
 Digital Inputs (Standard) 38
 Digital Outputs 38
 Drive Address 62
 Drive Datasheet 19
 Dwell Time 19

E

Electromagnetic Interference 28
 Encoder Feedback 12
 Encoder Following 15
 Encoder Index 12
 Encoder Inputs 40
 Environment 22
 Shock/Vibration 23
 Error Signal 11
 Extended Environment 23
 External Filter Card 20, 28

F

Fault Conditions 61–63
 Invalid Hall Commutation 62
 Over-Temperature 61
 Over-Voltage Shutdown 61
 Short Circuit Fault 62
 Under-Voltage Shutdown 61
 Feedback Polarity 11
 Feedback Supported 10–14
 Encoder 12
 Hall Sensors 12
 Feedback Wires 29
 Ferrite Suppression Cores 26
 Firmware 57
 Fold-back 63

G

Gearing Ratio 15
 Ground Loops 27, 29
 Grounding 27
 Controller Chassis 27
 Drive Case 27

Motor Chassis 27
 PCB Interface Chassis 27
 Power Supply Chassis 27
 Shielding 27

H

Hall Sensor Inputs 12, 39
 Hand Soldering 34
 Humidity 22, 23, 60

I

Impedance 28
 Indexing and Sequencing 15
 Inductive Filter Cards 26
 Input Reference Wires 30
 Input/Output Pin Functions
 Analog Input 54
 Auxiliary Encoder 40
 Digital Inputs 54
 Digital Outputs 54
 Interface Circuitry Examples 35
 Interference Coupling 28
 Invalid Hall Commutation 62

J

Jogging 15

L

Lock-out/tag-out Procedures 1
 Logic Supply Input 36

M

Magnetic Interference 28
 Manual Commutation 56
 Max. Continuous Current 5, 59
 Max. Peak Current 5, 59
 Maximum Power Dissipation
 at Continuous Current 5, 59
 Minimum Load Inductance 5, 59
 Model Information 64
 Model Mask 5
 Motor "Run-Away" 11, 63
 Motor Back EMF Constant 20
 Motor Current 19–21
 Motor Data 53
 Motor Inductance 3, 20
 Overload 63

Motor Line-to-Line Resistance	20	Position Control		Environment	22
Motor Power Output	37	Encoder	12	Motor	19
Motor Run-Away	63	Position Mode	9	Power Supply	20
Motor Specifications	19	Positive Feedback	11	System Voltage Requirement	20
Motor Speed	20	Power Ground	27		
Motor Torque Constant	19	Power Specifications	5	T	
Motor Voltage	20, 21	Power Supply Capacitance	3, 29	Technical Support	64
Motor Wires	28	Power Supply Output Current	21	Thermal Data	22
Mounting	31–33	Power Supply Specifications	20	Torque	19
PCB Mounting Options	34	Power Supply Wires	29	Trace Routing	33
Mating Connector	34	Product Label	64	Trace Width	33
Screw Mounting	34	Products Covered	5	Trademarks	ii
Soldering	34	Profile Current Mode	9	Trapezoidal Commutation	56
Move Profile	19, 21	Profile Position Mode	9	Troubleshooting	61–65
		Profile Velocity Mode	9	Twisted Pair Wires	28
		Protective Earth Ground	27		
N				U	
Negative Feedback	11	R		Under-Voltage Shutdown	61
Network Communication	15	Regeneration	20	User Units	53
Noise	28	Returns	65		
Nominal Power Supply Voltage	21	Revision History	iv	V	
		RS-232	46	Velocity Control	
O		RS-485	46	Encoder	12
Operation	52			Hall Sensors	13
Over the Network	15	S		Velocity Mode	9
Overload	63	Safety	1–3	Voltage Drop Interference	28
Over-Temperature	22, 61	Screw Mounting	34		
Over-Voltage Shutdown	61	Selective Wave Soldering	34	W	
		Shielding	27, 28	Warning Symbols	iii
P		Shock/Vibration	23	Warranty Info	65
Part Numbering Structure	5	Short Circuit Fault	62	Warranty Returns	65
PCB Design	33	Shunt Regulator	20	Wave Soldering	34
Circuitry Examples	35	Signal Connector	34	Wire Diameter	28
Analog Inputs	39	Signal Ground	27	Wire Gauge	28
DC Power	36	Sinusoidal Commutation	56	Wiring	28–30
Digital Inputs	38	Software Limits	62	Communication Wires	30
Digital Outputs	38	Soldering	34	Feedback Wires	29
Encoder	40	Space Vector Modulation	4	Impedance	28
Hall Sensors	39	Specifications Tables	59	Input Reference Wires	30
Logic Supply	36	Switching Frequency	5, 59	Motor Wires	28
Motor Power	37	System Requirements	19–23	Power Supply Wires	29
Trace Routing	33			Wire Gauge	28
Trace Width	33				
PCB Mounting Options	34				
PE Ground	27, 36, 37				
Peak Current Fold-back	63				

FlexPro Embedded Drives
Hardware Installation Manual
MNFPEMIN-12



3805 Calle Tecate • Camarillo, CA 93012-5068
Tel: (805) 389-1935 Fax: (805) 389-1165 www.a-m-c.com